

2024-2025

Cierre®

ISOLANTI ELETTRICI



Originalità

Innovazione

Garanzia

Professionalità



INNOVAZIONE

E

CAMBIAMENTO

INNOVATION AND CHANGE

Le aziende devono trovare le energie
per rinnovare e cambiare.

Companies must find the energy
to innovate and change.

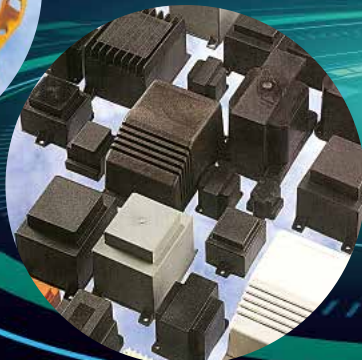
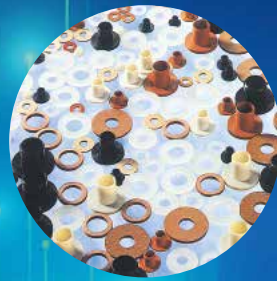



NINO CLIMELLI

Il fondatore

IL CLIENTE MERITA DI RICEVERE CIÒ CHE GLI ABBIAMO PROMESSO

- Poiché il cliente ha un bisogno, noi abbiamo un lavoro da fare.
- Poiché il cliente può scegliere, noi dobbiamo essere la scelta migliore.
- Poiché il cliente ha una sensibilità, noi dobbiamo tenerla in considerazione.
- Poiché il cliente ha un'urgenza, noi dobbiamo essere veloci.
- Poiché il cliente è unico, noi dobbiamo essere flessibili.
- Poiché il cliente ha aspettative molto alte, noi dobbiamo eccellere.
- Poiché il cliente è influente, noi abbiamo la speranza di nuovi clienti.

GRAZIE AL CLIENTE NOI ESISTIAMO

Management team



**SILVIA
CLIMELLI**



**BRUNO
CLIMELLI**



**ORNELLA
SIBONI**



**MARIA
SCIUTO**



**SERENA
DEL RIO**



**SALVATORE
MESSINA**



**CATIA
GARBELLINI**



**BARBARA
CHINI**

CONTA SOLO IL PREZZO, O FORSE NO?

È difficile trovare al mondo qualcosa che un uomo non possa fabbricare (copiare) leggermente peggio o vendere a più buon mercato... copiare è facile inventare no (3 su 3).

Diventa preda legittima di quest'uomo coloro che considerano solo il prezzo.

CieRre è qualità, originalità, tecnologia, conoscenza, professionalità, esperienza, certificazioni, al giusto prezzo e al vostro servizio.

CieRre non solo un marchio ma la garanzia di un partner affidabile per la sfida del terzo millennio dove nulla potrà essere lasciato al caso o all'improvvisazione...

("L'uomo allenato sta bene sulla cresta dell'onda, l'uomo che tenta, si affanna nel ricercare l'equilibrio")

...leader nel mondo con 20 diverse produzioni e ... 23 brevetti... i nostri prodotti vantano oltre 100 tentativi disperati di imitazione, cataloghi compresi ...

INDICE - INDEX

	PAGINA		
		Società	Firm - Firma
	2	ISO/Carta "UL" Cierre	ISO/yellow papers "UL" Cierre
	3	Informazioni azienda	Information business
	4	Classificazioni materiali	Material classification
	5-6	Carte gialle-materiale termoplastico	Yellow papers/thermoplastic materials
	7	Etichette identificazione prodotti	Labels/identification products
	103	Condizioni di vendita	General sales conditions
		Rocchetti in termoplastico	Coil forms in thermoplastic - Spulenkörper
	8	Legenda rocchetti	Coil - forms for legend
	9	Guscio - Guanciaie - Testate - Nervature	Cover and endplate - Side insulation
	10-11	EUR-CLASS Rocchetti e contenitori IP21 Guida DIN	Coil - forms and Boxes IP21 Din Rail (EUR-CLASS)
	12-31	Rocchetti per lamierino "EI"	Coil - forms for "EI"
	32-33	Rocchetti per nucleo "C"	Coil - forms for "C" core
	34-43	Rocchetti per lamierino "UI"	Coil - forms for "UI"
	45-46	Rocchetti fai da te "EI/UI"	Coil - forms by yourself "EI/UI"
	48-53	Rocchetti per ferrite	Coil - forms for ferrite
	60	Rocchetti basso profilo "UI30/UI39"	Coil - low profile "UI30/UI39"
	66	Rocchetti rotondi	Round coil formers
	30	Rocchetti UK	Coil - forms UK Imperial series
	47	Rocchetti e tubi in materiale isolante su disegno	Coil formers and tubes in insulating material on sketch
		Contenitori in termoplastico	Boxes in thermoplastic - Verguphauben
	54	Contenitore per ferriti	Box for ferriti
	57-59	Contenitore tipo orizzontale "EI"	Boxes horizontal type "EI"
	59	Contenitore tipo verticale "EI"	Boxes vertical type "EI"
	60	Contenitore basso profilo "UI30/UI39"	Boxes low profile "UI30/UI39"
	61-63	Contenitore per alimentatori	Boxes for power supplies
		Bussole - Rondelle	Bushings - Washers - Isolierbuchsen
	64-65	Bussola in termoplastico	Insulating bushing in thermoplastic
	64-65	Rondella in presspan-nylon	Washer in presspan-nylon
		Accessori per trasformatori	Accessories for transformers - Beiwerke für Transformatoren
	44	Zeppe/Camini	Fireplace/Wedges
	44	Stecche angolari e ossi di cane	Profile for transformers (dog's bone)
	67/75	Telai e Angolari in ferro "EI"	Frames and Angles steel "EI"
	70	Angolari in termoplastico "EI"	Angles "EI" in thermoplastic
	70	Supporto incastro DIN in plastica	Plastic DIN rail interlocking support
	73-75	Staffe "UI/UIT" con barre porta morsetti	Brackets "UI/UIT"
	33	Telai e accessori per nuclei "C"	Frames for "C" cores and accessories
	76	Calotte monofasi	Steel caps for single phase
	77	Supporto guida DIN in ferro	Iron DIN rail support
		Morsettiere	Terminal block - Klemmen
	78-79	Morsettiera tradizionale	Traditional terminal block
	80-81	Barrette portamorsetti "EI"	Terminal holder (bar of fixing "EI")
	81-90	Morsetti "UL"	Terminal block "UL" and bar of fixing
	55-56	Terminali	Terminal - Soldering connections - Lötanschlüsse
		Toroidali	Toroidal
	91-93	Anelli per nucleo toroidali	Ring for toroidal-core
	94	Dischi per nucleo toroidali	Disc for toroidal-core
	94	Scatole per illuminotecnica	Boxes for illumination
	94-96	Contenitore per nuclei toroidali	Box for toroidal-core
	99	Nastro adesivo dielettrico	Dielectric adhesive ribbon - Dielektrische klebeband
	99	Carte bachelizzate - Vetroresina	Bakelite - Glass-resin
		Carte dielettriche per avvolgimenti	Dielectric papers
	100	Presspan - Electron - Latheroide	Presspan - Electron - Latheroide
	101	Filmpoliestere-DMD	Film/polyester-DMD
	102	Celflex	Celflex
		Varie	Various
	33	Fascette in ferro per nuclei "C"	Iron clamps for "C" cores
	98	Guaine - Tubetti isolanti	Insulating hoses
	98	Casse per trasformatori trifase	Cases for three-phase transformers
	95	Stagno	Tin
	97	Cavallotti	Stampale in sheet zinc
	104	Notizie	News
	102	Prossime produzioni	Upcoming productions

CERTIFICATI

Siete così sprovveduti o amanti del rischio nell'acquistare dei prodotti senza certificazioni, controllo qualità, marchi, assicurazione prodotti? Se la risposta è "sì", non leggete questa pagina. Se la risposta è "no", siamo a vostra disposizione con la nostra esperienza, il nostro bagaglio tecnico, le nostre garanzie e i nostri marchi.

Le carte gialle sono valide solo se chi stampa ha il certificato UL (che certifica).

System Component, Electrical Insulation - Component E317429
JOHN C DOLPH CO
 320 NEW RD MONMOUTH JUNCTION NJ 08852

System Component	System Designation	System Temp(Class)
XL-2102, C(a)-1114, CR-1035, FDR-2102-3, CN-1130, CC-1024, CA-1123, CB-1135, XL-2112, CB-1078, CB-1135, CB-1109, CB-1054, CR-1050, CB-1128	DV-180C	180(H)

© 2013 UL LLC

Authorization Letter Required for Adoption of this System
Construction Details (Table V) alternate constructions

The use of this insulation system is limited to the combination of materials specified below. Where more than one item is designated under Insulation Function, they may be used together, unless otherwise indicated, or they may be used as alternates to one another. Functions designated "optional" are not necessarily required for every design. Insulation thicknesses and/or layers indicated below are minimum.

Minor Sheet Insulations (optional) layer, outer, wrap etc.

CIERRE
TYPE RP3
TYPE RP5
TYPE RP7

CERTIFICATE OF COMPLIANCE

Certificate Number: E238175
 Report Reference: E238175-20040628
 Date: 2022-April-11

Issued to: CIERRE S.R.L. A SOCIO UNICO
 VIA OSLAVIA 94
 DESIO , MI 20832 IT

This is to certify that representative samples of FABRICATED PARTS - COMPONENT Assigned Designation A1920 Covered under the Traceability Program

Have been investigated by UL in accordance with the component requirements in the Standard(s) indicated on this Certificate. UL Recognized components are incomplete in certain constructional features or restricted in performance capabilities and are intended for installation in complete equipment submitted for investigation to UL LLC.

Standard(s) for Safety: UL 746D, Polymeric Materials - Fabricated Parts.

Additional Information: See the UL Online Certifications Directory at <https://iq.ulprospector.com> for additional information

This Certificate of Compliance does not provide authorization to apply the UL Recognized Component Mark. Only the UL Follow-Up Services Procedure provides authorization to apply the UL Mark.

Only those products bearing the UL Recognized Component Mark should be considered as being UL Certified and covered under UL's Follow-Up Services.

Look for the UL Recognized Component Mark on the product.

CERTIFICATE OF COMPLIANCE

Certificate Number: E355624
 Report Reference: E355624-20130621
 Date: 2022-April-12

Issued to: CIERRE S.R.L. A SOCIO UNICO
 VIA OSLAVIA 94
 DESIO , MI 20832 IT

This is to certify that representative samples of TERMINAL BLOCKS - COMPONENT Series "K": Cat. No. K followed by M followed by 16A or 30A, followed by 1P or 2P, followed by K or FU

Have been investigated by UL in accordance with the component requirements in the Standard(s) indicated on this Certificate. UL Recognized components are incomplete in certain constructional features or restricted in performance capabilities and are intended for installation in complete equipment submitted for investigation to UL LLC.

Standard(s) for Safety: UL 1059, the Standard for Terminal Blocks.

Additional Information: See the UL Online Certifications Directory at <https://iq.ulprospector.com> for additional information

This Certificate of Compliance does not provide authorization to apply the UL Recognized Component Mark. Only the UL Follow-Up Services Procedure provides authorization to apply the UL Mark.

Only those products bearing the UL Recognized Component Mark should be considered as being UL Certified and covered under UL's Follow-Up Services.

Look for the UL Recognized Component Mark on the product.

IQNET Building trust together

Certificate

CSQ/IMG has issued an IQNET recognized certificate that the organization:

CIERRE SRL
 Via Oslavia 94 - 20832 DESIO (MI) Italy

has implemented and maintains a **Quality Management System**

for the following scope:
 Design and production of coil-formers and accessories in thermoplastic material for electrical insulating

which fulfills the requirements of the following standard:
ISO 9001:2015

Issued on: 2022/04/11
 Expires on: 2023/04/11

Registration Number: IT-26172-2190.CRRE

IMGQ CSQ is a member of IQNET

CERTIFICATE N° 2190.CRRE

REGISTRATION N° 2190.CRRE

CIERRE SRL
 VIA OSLAVIA 94 - 20832 DESIO (MI) Italy

has implemented and maintains a **Quality Management System**

for the following scope:
 Design and production of coil-formers and accessories in thermoplastic material for electrical insulating

which fulfills the requirements of the following standard:
ISO 9001:2015

Issued on: 2022/04/11
 Expires on: 2023/04/11

Registration Number: IT-26172-2190.CRRE

CieRre® s.r.l.

Via Oslavia, 94 - 20823 Desio (MB)
 Tel. +39-026420989 / 4 linee r.a.
 Fax. +39-026436855 / commerciale
 Fax. +39-0266116225 / contabilità

web: www.cierreint.it
 e-mail: cierre@cierreint.it

Per un miglior servizio, vi indichiamo le persone da contattare:

Direzione - Commerciale

Sig. Bruno Climelli
brunocli@cierreint.it

Uff. acquisti - vendite Italia

Sig.ra Silvia Climelli
cierre@cierreint.it

Direttore stabilimento

Certificazioni - qualità
 Sig. Salvatore Messina
salvatore.messina@cierreint.it

Uff. vendite e spedizioni Italia

Sig.ra Serena Del Rio
serena@cierreint.it
 Sig.ra Maria Sciuto
commerciale@cierreint.it

Ufficio tecnico/produzione

Sig. Bruno Climelli
brunocli@cierreint.it

Progettista

Sig. A. Maiorano
cierre@cierreint.it

Uff. vendite e spedizioni estero

Sig.ra Barbara Chini
barbara@cierreint.it

Amministrazione

Sig.ra Ornella Siboni contabilita@cierreint.it
 Sig.ra Catia Garbellini amministrazione@cierreint.it

Rivenditori estero con deposito



- ARGENTINA
- AUSTRALIA
- BELGIO
- CILE
- COLOMBIA
- EGITTO
- FRANCIA
- GRECIA
- GERMANIA
- INGHILTERRA
- ISRAELE
- LIBANO
- MAROCCO
- OLANDA
- PORTOGALLO
- SERBIA
- SPAGNA
- SVIZZERA
- URUGUAY
- VENEZUELA

Abbiamo 20 agenti con deposito nel mondo
 We have 20 representatives with warehouse in the world
 Nous avons 20 representantes avec magasins dans le monde

⊕ **6500 articoli per trasformatori**

⊕ **nel mondo non siamo i più grandi
 ma assolutamente i più completi**

⊕ **6500 items for transformers**

⊕ **in the world we are not the biggest
 but the most complete**

CARATTERISTICHE TECNICHE	NORME STANDARDS PRÜFVOSCHRIFT NORMES	RP3	RP4-Z	RP5	RP6	RP7	RP9
		Poliammide 6+35% FIBRA VETRO	Poliammide 6,6+30% FIBRA VETRO	Poliammide 6,6+25% FIBRA VETRO	Poliammide 6+50% FIBRA VETRO+SIV	Pet+ 30% FIBRA VETRO	Poliammide 6 SENZA CARICA
MECCANICHE: Carico di rottura Ultimate tensile strenght Reißfestigkeit Tension de ripture	ASTM D638 ISO/VE D/527 DIN 53455	100	140	150	120	165	61
ELETTRICHE: Rigidità dielettrica Dielectric strenght Durchschlagfestigkeit Rigidité diélectrique	ASTM D149	40	45	20	40	29	21
Costante dielettrica Dielectric constant Dielektrizitätszahl Constante diélectrique	ASTM D150 ISO/VE 0303/4 DIN 53873	12,6	9,6	9,7	12,6	3,7 (100 Hz)	12,1
Resist. a correnti striscianti proc. KC (sol. di prova F) Resistance to tracking Kriechstromfestigkeit Résistance au courant de cheminement	IEC 60112 ASTM D150 ISO/VE 0303/1 DIN 53480	KC 475	KC 550	KC 550	KC 550	KC 225	KC 175
Assorbimento d'acqua a 23°C in acqua per 24h Water absorption at 23°C in water foe 24h Wasseraufnahme bei 23°C 24 SDStunden in wasser Absorption d'eau à 23°C en eau pedant 24h	ASTM D570 ISO/62	0,90	0,80	0,70	0,75	0,40	1,60
GLOW WIRE TEST PROVA FILO INCANDESCENTE	GWT IEC 695-2-11	650	700	IEC 60695-2-12 IEC GWIT 725 IEC GWFI 960	650	IEC 60695-2-13 IEC GWIT 800 IEC GWFI 960	650
TERMICHE: Temperatura di impiego continuo senza sollecitazione Continuous service temperature with no stress Andauernde Anwendungstemperatur ohne Belastung Température d'emploi en continu sans contrainte	20000 h IEC 85 ASTM ISO/VE UL 1446	155°	130°	130°	155°	180°	105°
Temperature limite di impiego per brevi durate Maximum service temperature (short term) Temperaturgrenze bei kurzen Einsatzzeiten Température maximale pour un emploi de courte durée	3000 h IEC 216 ASTM ISO/VE DIN	160°	155°	150°	180°	200°	120°
Infiammabilità Flammability Brandverhilten Infiammabilité	SEC.ASTM SEC.U.I. ASTM D635 ISO/VE DIN ASTM ISO/VE	BRUCIA	BRUCIA	AUTO ESTINGUENTE	BRUCIA	AUTO ESTINGUENTE	AUTO ESTINGUENTE
		HB	HB	VO	HB	VO	V2/VO

TUTTI I NOSTRI MATERIALI SONO FORNITI CON CERTIFICAZIONE E CARTA GIALLA

Le carte gialle sono valide solo se chi stampa ha il certificato UL (che certifica).

CLASSE DI APPROVAZIONE
APPROVAL CLASS

NOME FABBRICANTE
NAME OF THE MANUFACTURER

DESCRIZIONE DEL PRODOTTO- COLORE
MATERIAL DESIGNATION COLOURS

DATA DI PUBBLICAZIONE DELLA CARTA
DATE OF PUBLICATION OF THE PAPER

NUMERO (FILE) DELLA CARTA
NUMBER OF FILE

SPESSORE MINIMO DEL CAMPIONE ESAMINATO
MINIMAL WALL THICKNESS

UL 94 CLASSIFICAZIONE RESISTENZA ALLA FIAMMA
UL - FLAMMABILITY

RTI INDICE DI TEMPERATURA RELATIVA
RTI RELATIVE TEMPERATURE

RTI - ELETTRICO
RTI - ELECTRICAL

RTI - MECCANICO CON URTO
TRI - MECHANICAL WITH IMPACT

RTI - MECCANICO SENZA URTO
RTI - MECHANICAL WITHOUT IMPACT

CTI - COMPARATIVE TRACKING INDEX
CTI - INDICE DI TRACKING COMPARATIVO

D495 - ARC RESISTANCE
D495 - RESISTENZA DELL'ARCO

HVTR - HIGH VOLTAGE ARC TRACKING RATE
HVTR - VELOCITÀ DI TRACKING CON ARCO AD ALTA TENSIONE

HAI - HIGH AMPERE ARC IGNITION
HAI - ACCENSIONE CON ARCO AD ALTO AMPERAGGIO

HWI - HOT WIRE IGNITION
HWI - ACCENSIONE A FILO CALDO

Min Thk mm	UL94 Flame Class	Elec	RTI Mech with Imp	RTI w/o Imp
0.79	94V.0	60	60	60
0.79	94V.0	65	65	65
1.60	94V.0	65	65	65
1.60	94V.0	65	65	65
1.60	94V.0	65	65	65

UL 94 CLASSIFICAZIONE RESISTENZA ALLA FIAMMA: Esistono 6 classificazioni.

UL 94-5VA: Questa è la classificazione UL94 più alta (più ritardante di fiamma), i test di prova NON POSSONO avere fori.

UL 94-5VB: Arresto della combustione entro 60 secondi, i test POTREBBERO ESSERE bruciati.

Questi due test hanno un'accensione di fiamma 5 volte più grave di quella usata per gli altri a seguire.

UL 94-5V-0I: La masterizzazione si arresta entro 10 secondi, NON sono ammessi gocciolamenti fiammeggianti.

UL 94-5V-1: La masterizzazione si arresta entro 60 secondi, NON sono ammessi gocciolamenti fiammeggianti.

UL 94-5V-2: La masterizzazione si arresta entro 60 secondi, sono ammessi gocciolamenti fiammeggianti.

UL 94-HB: La classificazione UL94 più bassa (brucia).

RTI INDICE DI TEMPERATURA RELATIVA: bisogna fare attenzione a non confondere l'indice di temperatura relativa con le classi termiche (IEC85 - U.L.1446) delle quali forniamo, nella pagina 4 tutti i criteri di specifica.

HWI-HOT WIRE IGNITION: (U.L.746A42) viene indicato il tempo che passa fino all'accensione del campione, nel caso un elemento conduttore che subisca un carico eccessivo e si trovi a contatto con il campione stesso.

HAI-HIGH AMPERE ARC IGNITION: (U.L.746A43) le cifre indicano il numero di accensioni di archi voltaici necessari a produrre un'accensione del campione. Il criterio di esito negativo è l'accensione del campione posto vicinissimo all'arco.

HVTR-HIGH VOLTAGE ARC TRACKING RATE: (U.L. 746 A44) il numero riprodotto sulla scheda indica in mm/min la lunghezza del tratto conduttivo che si forma sulla superficie del campione da parte di un arco voltaico ad alta tensione.

D495-ARC RESISTANCE: (ASTM D495) il tempo indicato in secondi, è quello che trascorre fino a quando un'arco elettrico si spegne tra le pinze dell'apparecchio di prova, per azione di una traccia dispersione a bassa resistenza, sulla superficie del campione. I materiali sono classificati in categorie.

CTI-COMPARATIVE TRACKING INDEX è espresso come la tensione che causa il tracking a seguito della caduta sul materiale di 50 gocce di soluzione al 0,1% di cloruro d'ammonio. I risultati delle prove sugli spessori nominali da 3 mm sono considerati rappresentativi per tutti gli spessori.

CARTE GIALLE / YELLOW PAPERS / GELBE PAPIER

Le carte gialle sono valide solo se chi stampa ha il certificato UL (che certifica).

RP3

E 43392

Envalior

K224-HG6(f1)

Polyamide 6 (PA6), glass reinforce 30% "Akulon"



Color	Min. Thk (mm)	Flame Class	HWI	HAI	RTI Elec (°C)	RTI Imp (°C)	RTI Str (°C)
ALL	0.71	HB	2	0	140	120	140
	1.5	HB	1	0	140	125	150
	3.0	HB	0	0	140	135	150

Comparative Tracking Index (CTI): 1 Volume Resistivity (10⁴ ohm-cm): 13
Dielectric Strength (kV/mm): 15 High Volt, Low Current Arc Resis (D495): 6
High-Voltage Arc Tracking Rate (HVTR): 1

(f1) - Suitable for outdoor use with respect to exposure to Ultraviolet Light, Water Exposure and Immersion in accordance with UL 746C.

RP4 - Z

E 41938

QMFZ2 Component - Plastics
CELANESE INTERNATIONAL CORP
8040 DIXIE HWY, FLORENCE KY 41042-2904



Material Designation: 70G30HSL, 70G30HSLR

Product Description: Polyamide 66 (PA66), glass reinforced, designated "Zytel" furnished as pellets.

Color	Min. Thick. (mm)	Flame Class	HWI	HAI	RTI Elec (°C)	RTI Imp (°C)	RTI Str (°C)	IEC GWIT	IEC GWFI
NC, BK	0.75	HB	4	0	140	125	140	-	-
	1.5	HB	4	0	140	125	140	-	-
	3.0	HB	1	0	140	125	140	-	-

NOTE (1) Material designations that are color pigmented may be followed by suffix letters and numbers. (2) Material designations may be prefixed by "ZYT" or "MIN".

Report Date: 08/07/1996 Underwriters Laboratories Inc.® 324299147

UL94 small-scale test data does not pertain to building materials, furnishings and related contents. UL 94 small-scale test data is intended solely for determining the flammability of plastic materials used in components and parts of end-product devices and appliances, where the acceptability of the combination is determined by U.L.

RP5

E 54080

Guide Information

LATI INDUSTRIA TERMOPLASTICI SPA
VIA BARACCA 7, VEDuggIO OLONA VA 21040 IT

LATAMID 66 H2 G/25-V0KB (q) (r)
Polyamide 66 (PA66), furnished as pellets

View Certificate of Compliance



Color	Min. Thk (mm)	Flame Class	HWI	HAI	RTI Elec (°C)	RTI Imp (°C)	RTI Str (°C)
NC, BK	0.75	V-0	3	0	100	75	75
	1.5	V-0	1	0	100	80	80
	3.0	V-0	1	0	100	85	85

Comparative Tracking Index (CTI): 1 Inclined Plane Tracking (IPT) kV: -
Dielectric Strength (kV/mm): - Volume Resistivity (10⁴ ohm-cm): -
High-Voltage Arc Tracking Rate (HVTR): 1 Surface Resistivity (10⁴ ohms/square): -
Dimensional Change (%): - High Volt, Low Current Arc Resis (D495): 6

(q) - Optional marking consisting of a generic indication of color (English or Italian) followed by an alphanumeric code (consisting of 4 digits and 1 letter) indicating color shade.

(r) - Optional marking consisting of an alphanumeric code (consisting of 1 or 2 letters followed by one number) referring to manufacturing process information.

ANSUL 94 small-scale test data does not pertain to building materials, furnishings and related contents. ANSUL 94 small-scale test data is intended solely for determining the flammability of plastic materials used in the components and parts of end-product devices and appliances, where the acceptability of the combination is determined by U.L.

RP5

E 54080

Component - Plastics

LATI INDUSTRIA TERMOPLASTICI SPA
VIA BARACCA 7, VEDuggIO OLONA VA 21040 IT

LATAMID 66 H2 G/25-V0HF1 (q)(r)(f2)
Polyamide 66 (PA66) "LATAMID", furnished as pellets

View Certificate of Compliance



Color	Min. Thk (mm)	Flame Class	HWI	HAI	RTI Elec (°C)	RTI Imp (°C)	RTI Str (°C)
ALL	0.3	-	-	-	65	65	65
GY	0.5	HB	-	-	130	65	65
ALL	0.75	V-0	0	0	130	130	130
	1.0	V-0	0	0	130	130	130
	1.5	V-0, SVA	0	0	130	130	130
	3.0	V-0, SVA	0	0	130	130	130

Comparative Tracking Index (CTI): 0 Inclined Plane Tracking (IPT) kV: 1
Dielectric Strength (kV/mm): 9 Volume Resistivity (10⁴ ohm-cm): 9
High-Voltage Arc Tracking Rate (HVTR): - Surface Resistivity (10⁴ ohms/square): -
Dimensional Change (%): - High Volt, Low Current Arc Resis (D495): -

RP6

E 43392

Envalior

K224-Go

Polyamide 6 (PA6), glass reinforce 50% "Akulon"



Color	Min. Thick. (mm)	Flame Class	HWI	HAI	RTI Elec (°C)	RTI Imp (°C)	RTI Str (°C)
ALL	0.75	HB	3	0	65	65	65
	1.5	HB	2	0	65	65	65
	3.0	HB	0	0	65	65	65

Comparative Tracking Index (CTI): 0 Volume Resistivity (10⁴ ohm-cm): 11
Dielectric Strength (kV/mm): 20 High Volt, Low Current Arc Resis (D495): 5
High-Voltage Arc Tracking Rate (HVTR): 0

RP7

E 43392

Envalior

AV2360S

Polythylene terephthalate (PET), glass reinforced 30% "Arite"



Color	Min. Thick. (mm)	Flame Class	HWI	HAI	RTI Elec (°C)	RTI Imp (°C)	RTI Str (°C)
ALL	0.7	V-2	3	0	150	125	140
	1.5	V-0	0	3	150	125	140
	3.0	V-0	0	3	150	125	140

Dielectric Strength (kV/mm): 30 High Volt, Low Current Arc Resis (D495): 6
High-Voltage Arc Tracking Rate (HVTR): 4
Dimensional Change (%): 0

RP7

E 41938

CELANESE INTERNATIONAL CORP

8040 DIXIE HWY, FLORENCE KY 41042-2904

FR530(L)(+)(F1), FR530(L)(+)(F1)

Polyethylene Terephthalate (PET), glass reinforced, flame retardant "Nyrile", furnished as pellets [contains mechanically recycled content]



Attention Materials Users! This product Certification has been changed on 2023-02-16. UL94 Flame class has been revised [click here to learn more](#)

Color	Min. Thk (mm)	Flame Class	HWI	HAI	RTI Elec (°C)	RTI Imp (°C)	RTI Str (°C)
NC, BK	0.35	V-0	3	1	155	155	155
ALL	0.75	V-0	2	1	155	155	155
NC, BK	1.5	V-0, SVA	0	1	155	155	155
ALL	2.0	V-0, SVA	0	1	155	155	155
	3.0	V-0, SVA	0	1	155	155	155

Comparative Tracking Index (CTI): 2 Inclined Plane Tracking (IPT) kV: -
Dielectric Strength (kV/mm): 34 Volume Resistivity (10⁴ ohm-cm): 16
High-Voltage Arc Tracking Rate (HVTR): 1 Surface Resistivity (10⁴ ohms/square): -
Dimensional Change (%): 0 High Volt, Low Current Arc Resis (D495): 6

RP9

Status of U.L. approvals, Product Certified for Canada included

LATI S.p.A - updated 2 November 2006

file LATI : E54080 - QMFZ2, QMFZ8



R.T.I.

Product	CUR	Material	Colors	Elec		Mech		H D							
				mm	Class	Imp	Imp	I	I	R	5	I			
		Latamid 6 BH	ALL	0,75	V-2	140	90	115	4	0					
				1,50	V-2	140	95	115	4	0					
				3,00	V-2	140	95	115	3	0	0	5	0		

RP11

LATI INDUSTRIA TERMOPLASTICI SPA

VIA BARACCA 7, VEDuggIO OLONA VA 21040 IT

LATAMID 6 H2 G/20-V2HF(f2) (q) (r)

Polyamide 6 (PA6), furnished as pellets

UL-FILE: E54080

Color	Min. Thk (mm)	Flame Class	HWI	HAI	RTI Elec (°C)	RTI Imp (°C)	RTI Str (°C)
ALL	0.75	V-2	2	0	120	115	115
	1.5	V-2	2	0	120	120	120
	3.0	V-2	2	0	120	120	120

Comparative Tracking Index (CTI): 1 Inclined Plane Tracking (IPT) kV: -
Dielectric Strength (kV/mm): - Volume Resistivity (10⁴ ohm-cm): -
High-Voltage Arc Tracking Rate (HVTR): 1 Surface Resistivity (10⁴ ohms/square): -
Dimensional Stability (%): - High Volt, Low Current Arc Resis (D495): 6

(f2) - Subjected to one or more of the following tests: Ultraviolet Light, Water Exposure or Immersion in accordance with UL 746C, where the acceptability for outdoor use is to be determined by U.L.

(q) - Optional marking consisting of a generic indication of color (English or Italian) followed by an alphanumeric code (consisting of 4 digits and 1 letter) indicating color shade.

(r) - Optional marking consisting of an alphanumeric code (consisting of 1 or 2 letters followed by one number) referring to manufacturing process information.

ANSUL 94 small-scale test data does not pertain to building materials, furnishings and related contents. ANSUL 94 small-scale test data is intended solely for determining the flammability of plastic materials used in the components and parts of end-product devices and appliances, where the acceptability of the combination is determined by U.L.

Report Date: 1983-06-01

Last Revised: 2013-04-23

© 2019 UL LLC



ETICHETTE IDENTIFICAZIONE PRODOTTO

PRODUKTIDENTIFIZIERUNGSE TIKETTEN

IDENTIFICATION PRODUCTS LABELS

CieRe [®]		Sede e Stabilimento: 20832 Desio (MB) - Italy Via Oslavia, 94 Tel. 02.6420989 www.cierreint.it		IDENTIFICAZIONE PRODOTTO	
CLIENTE			DENOMINAZIONE		
CODICE				ESP. MOD.	
RR. MATERIALE Materiale AKULON K224 HG6 Fornitore: DSM		RP3		COLORE	N° PEZZI
N° ORD. PROD.		DATA PRODUZIONE	OPERATORE	COD. FORN.	
				VISTO C.Q.	VISTO VQU

CieRe [®]		Sede e Stabilimento: 20832 Desio (MB) - Italy Via Oslavia, 94 Tel. 02.6420989 www.cierreint.it		IDENTIFICAZIONE PRODOTTO	
CLIENTE			DENOMINAZIONE		
CODICE				ESP. MOD.	
RR. MATERIALE Materiale LATAMID 66 H2 G/25 VOKB Fornitore: LATI		RP5		COLORE	N° PEZZI
N° ORD. PROD.		DATA PRODUZIONE	OPERATORE	COD. FORN.	
				VISTO C.Q.	VISTO VQU

CieRe [®]		Sede e Stabilimento: 20125 MILANO (Italy) Via Ugolini, 10/12 Tel. 02.6420989 Fax 02.6436855		IDENTIFICAZIONE PRODOTTO	
CLIENTE			DENOMINAZIONE		
CODICE				ESP. MOD.	
RR. MATERIALE Materiale ZYTEL 70G30HSL Fornitore DU PONT		RP4-Z		COLORE	N° PEZZI
N° ORD. PROD.		DATA PRODUZIONE	OPERATORE	COD. FORN.	
				VISTO C.Q.	VISTO VQU

CieRe [®]		Sede e Stabilimento: 20832 Desio (MB) - Italy Via Oslavia, 94 Tel. 02.6420989 www.cierreint.it		IDENTIFICAZIONE PRODOTTO	
CLIENTE			DENOMINAZIONE		
CODICE				ESP. MOD.	
RR. MATERIALE Materiale LATAMID 6 H2 G/50 Fornitore: LATI		RP6		COLORE	N° PEZZI
N° ORD. PROD.		DATA PRODUZIONE	OPERATORE	COD. FORN.	
				VISTO C.Q.	VISTO VQU

CieRe [®]		Sede e Stabilimento: 20125 MILANO (Italy) Via Ugolini, 10/12 Tel. 02.6420989 Fax 02.6436855		IDENTIFICAZIONE PRODOTTO	
CLIENTE			DENOMINAZIONE		
CODICE				ESP. MOD.	
RR. MATERIALE Materiale ARNITE AV2 360S Fornitore DSM		RP7		COLORE	N° PEZZI
N° ORD. PROD.		DATA PRODUZIONE	OPERATORE	COD. FORN.	
				VISTO C.Q.	VISTO VQU

CieRe [®]		Sede e Stabilimento: 20832 Desio (MB) - Italy Via Oslavia, 94 Tel. 02.6420989 www.cierreint.it		IDENTIFICAZIONE PRODOTTO	
CLIENTE			DENOMINAZIONE		
CODICE				ESP. MOD.	
RR. MATERIALE Materiale LATAMID 6 H2 G/20-V2 HF Fornitore LATI		RP11		COLORE	N° PEZZI
N° ORD. PROD.		DATA PRODUZIONE	OPERATORE	COD. FORN.	
				VISTO C.Q.	VISTO VQU

CieRe [®]		Sede e Stabilimento: 20125 MILANO (Italy) Via Ugolini, 10/12 Tel. 02.6420989 Fax 02.6436855		IDENTIFICAZIONE PRODOTTO	
CLIENTE			DENOMINAZIONE		
CODICE				ESP. MOD.	
RR. MATERIALE Materiale LATAMID 6 BH Fornitore: LATI		RP9		COLORE	N° PEZZI
N° ORD. PROD.		DATA PRODUZIONE	OPERATORE	COD. FORN.	
				VISTO C.Q.	VISTO VQU

Le etichette vengono stampate in diversi colori in base al tipo di materiale utilizzato e permettono una migliore identificazione e rintracciabilità del prodotto.

Different colours for every material-type

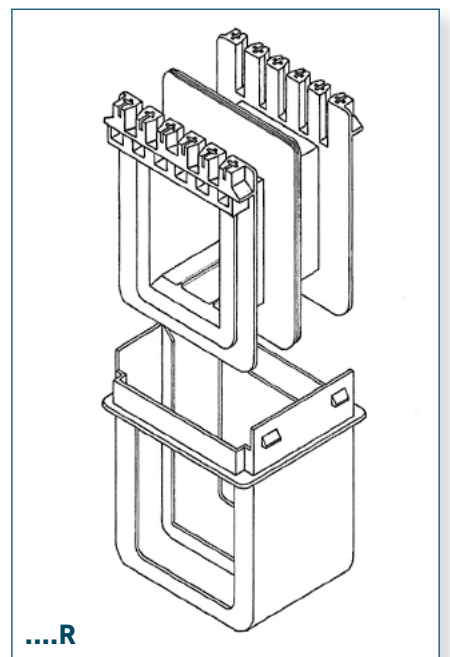
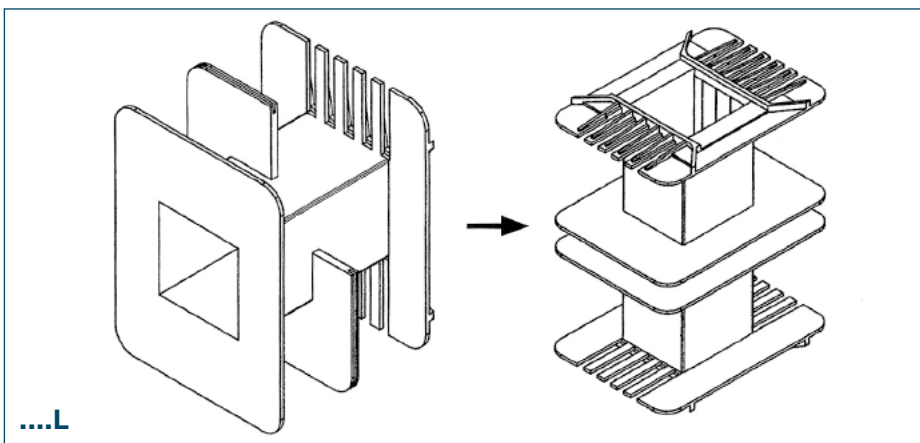
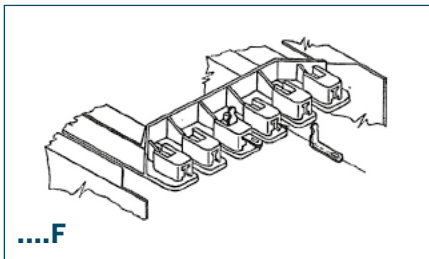
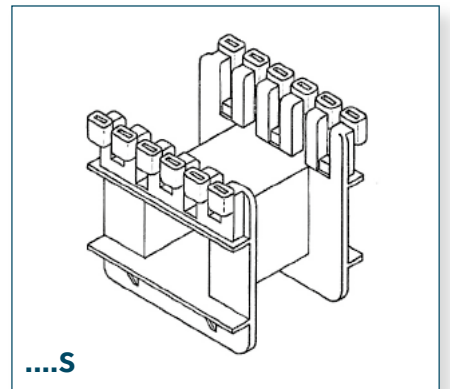
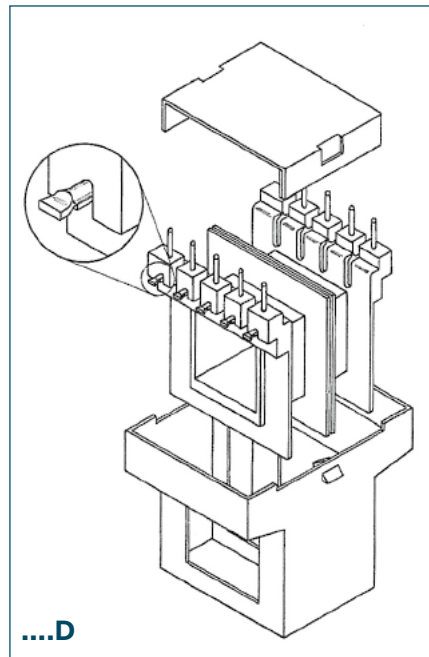
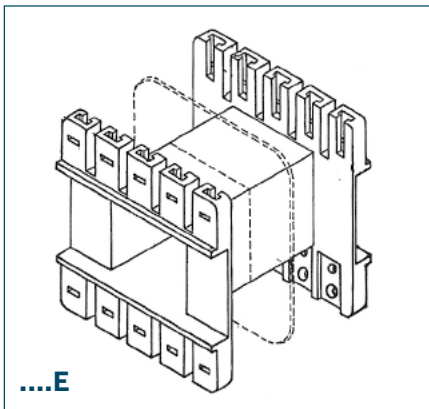
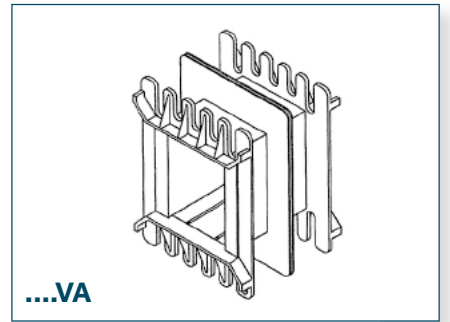
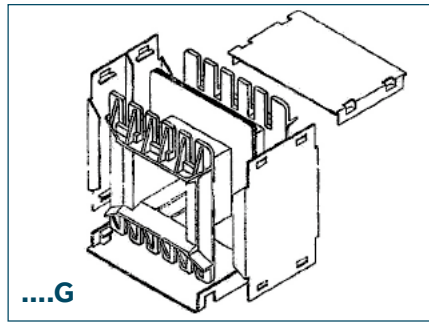
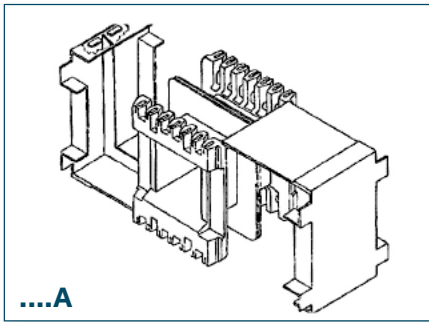
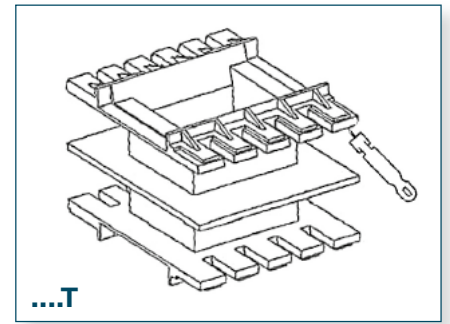
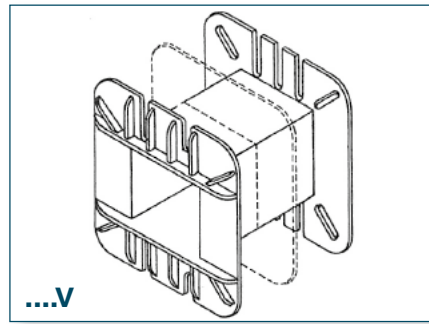
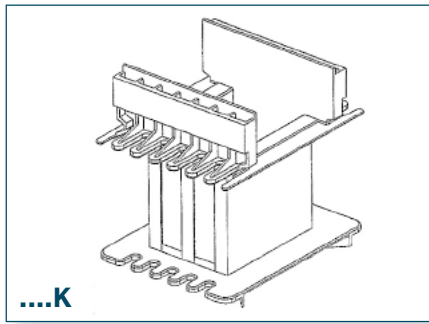

SIDE INSULATION / SCHUTZHAUBE SEITENI SOLATIONEN SCHUTZDECKEL

I nostri GUSCI - GUANCIALI - TESTATE permettono di ricoprire completamente il rocchetto mantenendo costanti le distanze in aria.

VANTAGGI

1. Sono corrispondenti alle norme CEI e/o VDE
2. Permettono di non usare le carte isolanti come ultimo strato rendendo gradevole anche l'aspetto estetico
3. Le alette esterne (fig.1) isolano il lamierino dal rame, le alette interne (fig.2) che si incastrano nella flangia intermedia permettono di mantenere le distanze in aria. Le borchie (fig.3) sono indispensabili in caso di rotture o allentamento fili perchè evitano nel punto più critico (l'angolo) la fine delle distanze in aria.

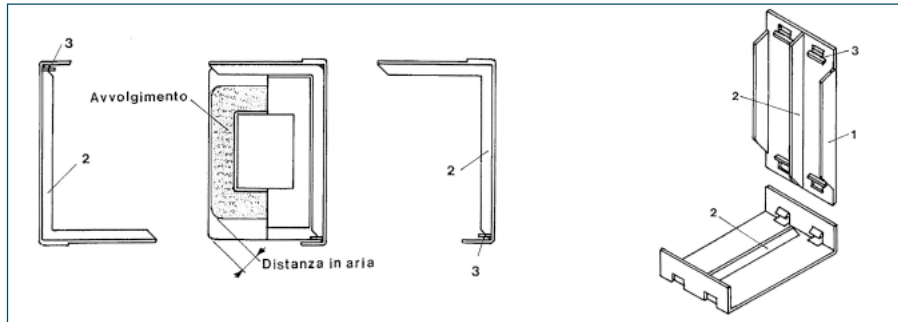

Tutti i nostri rocchetti sono dotati di 2/3 nervature interne nel tubo per permettere a chi usa le tradizionali macchine impacchettatrici di poter infilare fino all'ultimo lamierino senza doverlo fare manualmente.

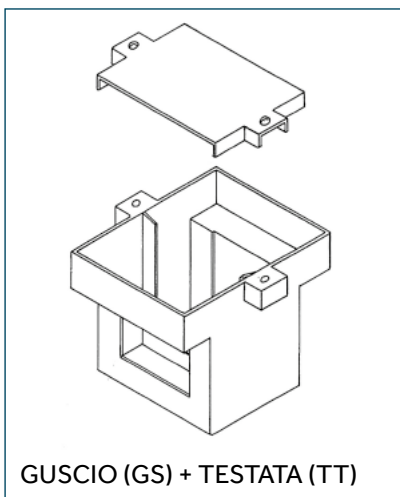

GUSCIO (GS) + TESTATA (TT)

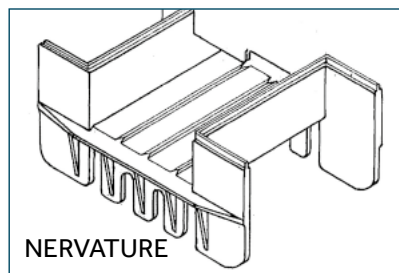

NERVATURE

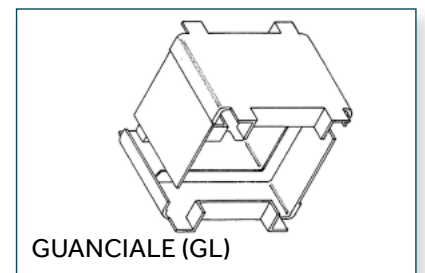

GUANCIALE (GL)

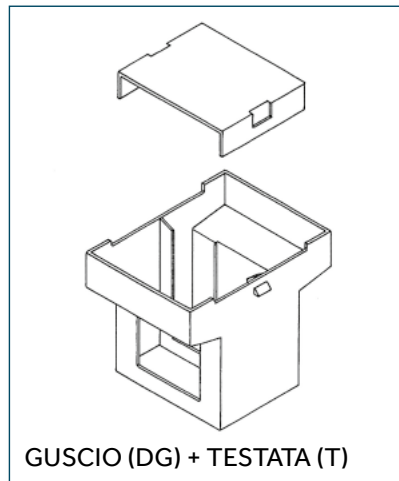

GUSCIO (DG) + TESTATA (T)

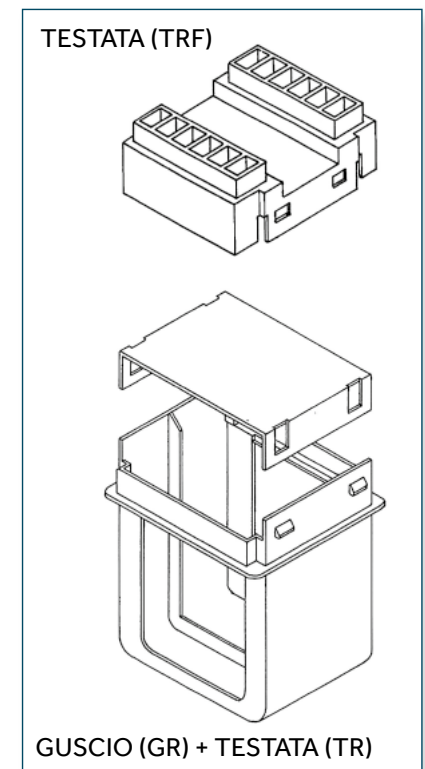

TESTATA (TRF)

GUSCIO (GR) + TESTATA (TR)

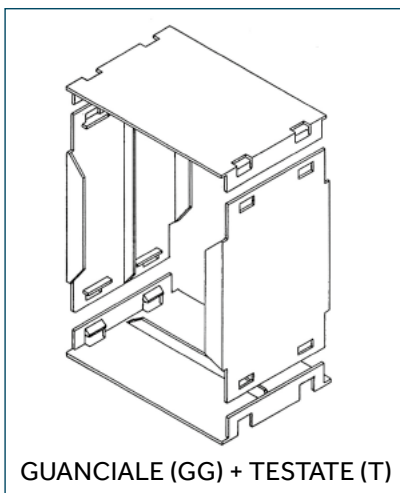

GUANCIALE (GG) + TESTATE (T)

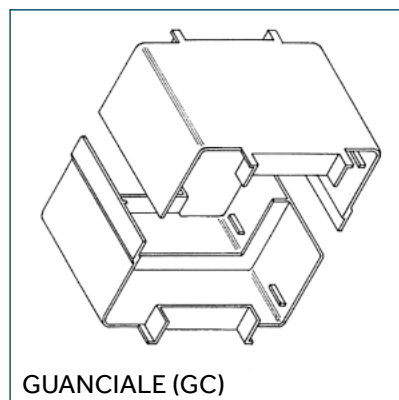

GUANCIALE (GC)

L'INNOVAZIONE PER COSTRUIRE TRASFORMATORI DIN RAIL SERIE EUR CLASS

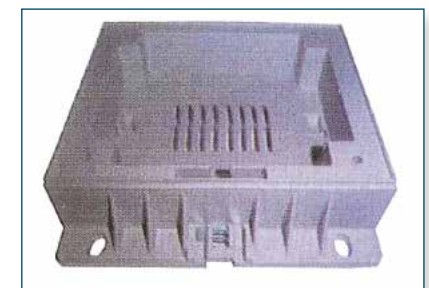
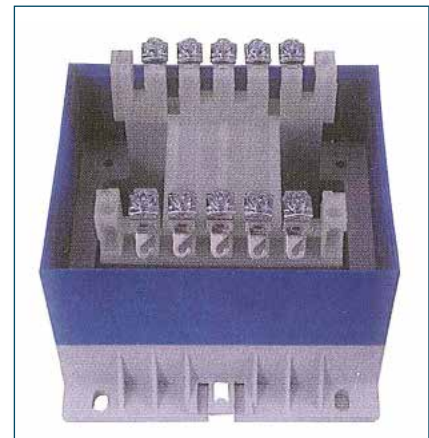
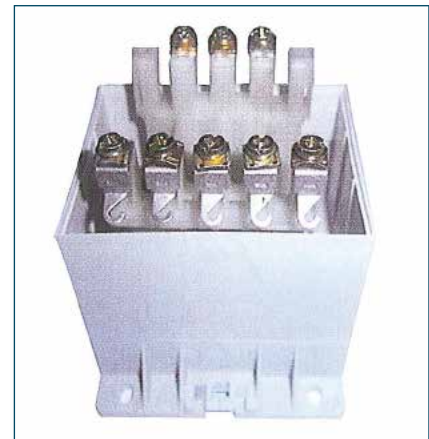
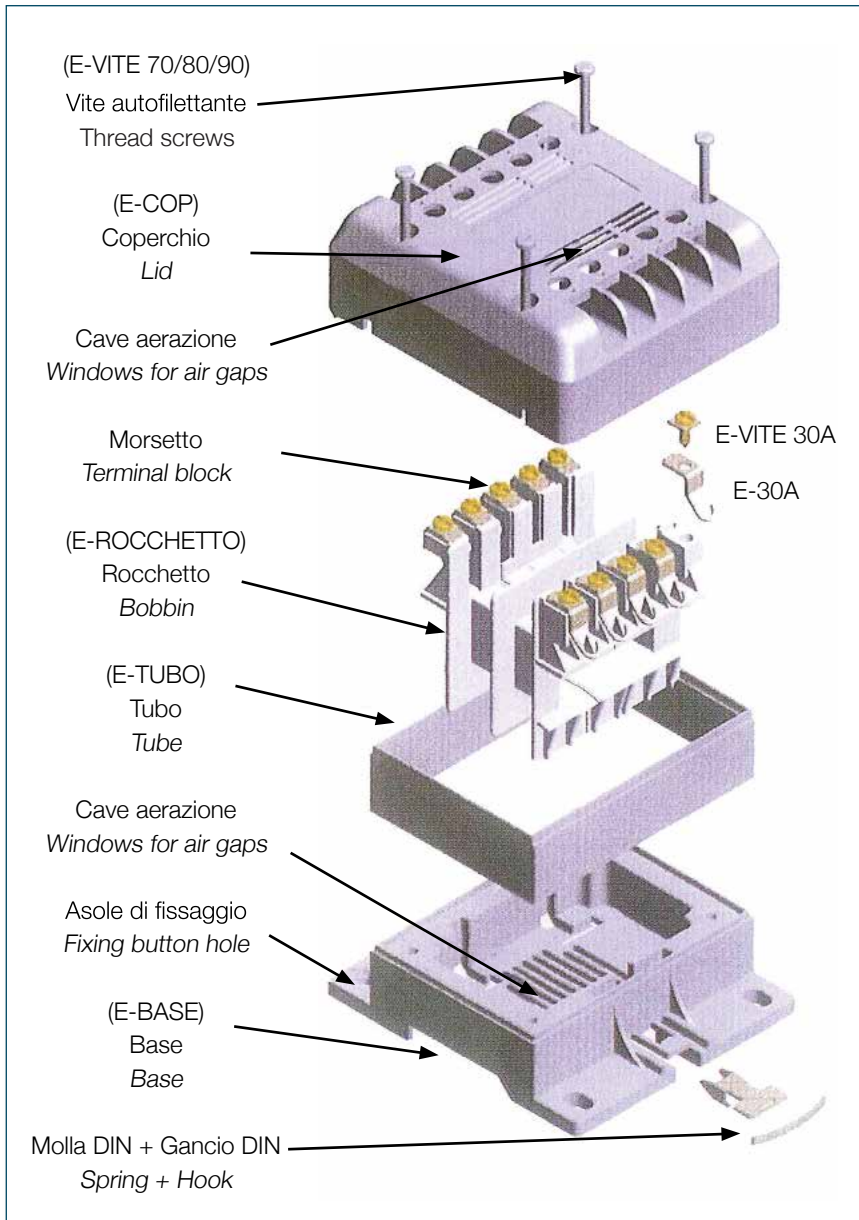
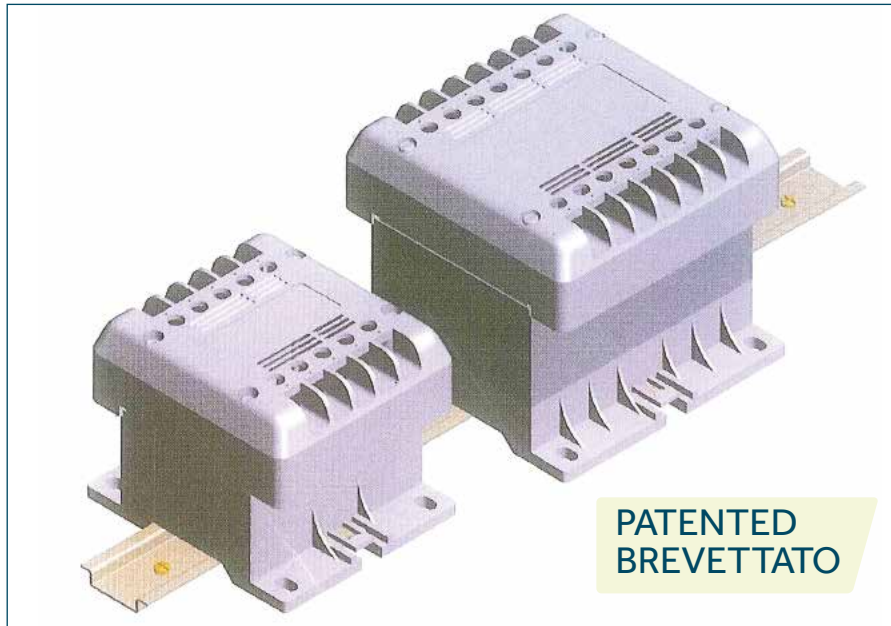

SERIE EUR-CLASS / INNOVATIONS FOR DIN RAIL TRANSFORMERS

NEVENTWICKLUGEN FÜR DIN RAIL TRANSFORMATOREN

Caratteristiche

- Parti attive non accessibili
- Grado di protezione IP21 e classe II di isolamento
- Aggancio per guida DIN e doppia possibilità di fissaggio a sole
- Rocchetti con/senza flangia intermedia
- El 84 rocchetti 5+5 morsetti
- El 96 rocchetti 6+6 morsetti
- El 120 rocchetti 7+7 morsetti
- Materiale autoestinguente
- Colori: grigio/blu
- Cave di aerazione
- Viti autofilettanti

Features:

- Active parts not accessible
- Degree of protection IP21 and c/ass II of insulation
- Coupling for guide DIN and double possibility of fixing with button hole
- Bobbins with/without central flag
- El 84 bobbins 5 + 5 terminal blocks
- El 96 bobbins 6 + 6 terminal blocks
- El 120 bobbins 7 + 7 terminal blocks
- Material UL94VO
- Colours: grey/blue
- Windows for air gaps
- Thread screws

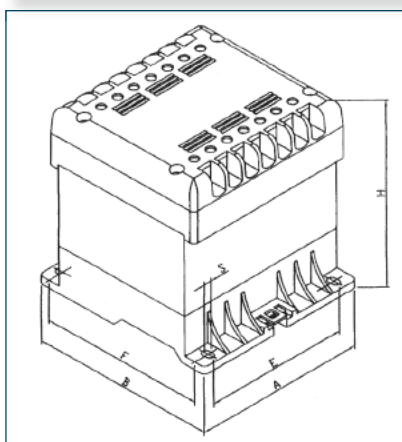
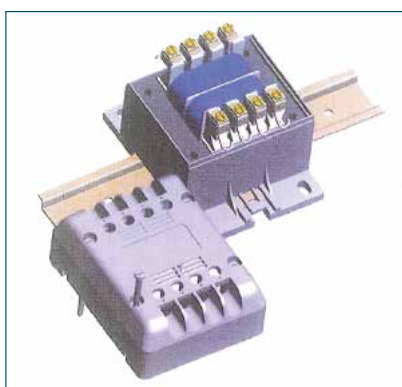

ACCESSORI / ACCESSORIES

TYPE	REF.	DESCRIZIONE
EI 84	E-COP 28	COPERCHIO 28
EI 96	E-COP 32	COPERCHIO 32
EI 120	E-COP 40	COPERCHIO 40
EI 84	E-TUBO 2830	TUBO 28 X 30
EI 84	E-TUBO 2840	TUBO 28 X 40
EI 84	E-TUBO 2850	TUBO 28 X 50
EI 96	E-TUBO 3240	TUBO 32 X 40
EI 96	E-TUBO 3250	TUBO 32 X 50
EI 96	E-TUBO 3260	TUBO 32 X 60
EI 120	E-TUBO 4040	TUBO 40 X 40
EI 120	E-TUBO 4050	TUBO 40 X 50
EI 84	E-BASE 28	BASE 28
EI 96	E-BASE 32	BASE 32
EI 120	E-BASE 40	BASE 40

TYPE	REF.	A	B	H	E	F	S	KG	TUBO	E-VITE
EUR CLASS	ROCHETTO	mm	mm	mm	mm	mm	mm	mm		autofilettante
EI 84/30	E 2830/1-2	90	106	87	68,5	90	4,5	1,1	■	E-VITE 70
EI 84/35	E 2835/1-2	90	106	96	68,5	90	4,5	1,6		E-VITE 80
EI 84/40	E 2840/1-2	90	106	106	68,5	90	4,5	1,9	■	E-VITE 80
EI 84/50	E 2850/1-2	90	106	116	68,5	90	4,5	2,3	■	E-VITE 90
EI 96/40	E 3240/1	102	115,5	106	82	101,5	5,0	3,3	■	E-VITE 80
EI 96/50	E 3250/1	102	115,5	116	82	101,5	5,0	3,7	■	E-VITE 80
EI 96/60	E 3260/1	102	115,5	126	82	101,5	5,0	3,9	■	E-VITE 90
EI 120/40	E 4040/1-2	126	136	117	96	121	5,5	4,4	■	E-VITE 80
EI 120/50	E 4050/1-2	126	136	127	96	121	5,5	5,3	■	E-VITE 90

ROCCHETTI MONOFASE "EI"
COIL FORMS "EI"
CARCASSES "EI"
CARRETES "EI"
EINPHASIGE SPULEN "EI"



ROCCHETTI IN MATERIALE TERMOPLASTICO SPULEN AUS THERMOPLASTISCHEN STOFF

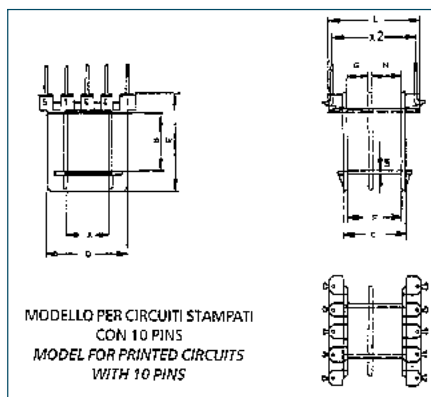

EI 30

Lam. 25X30

TYPE	REF.	A	B	C	D	E	F	G	H	L	S	numero term.	x2
EI 30/10,5	1010N/1-2	10,4	10,5	14,6	19,5	19,5	12,3	7,0	5,1	22,0	0,7	2X5	20
EI 30/12,5	1012N/1-2	10,4	12,5	14,6	19,5	24,5	12,3	7,0	5,1	22,0	0,7	2X5	20
EI 30/15,2	1015N/1-2	10,4	15,5	14,6	19,5	24,5	12,3	7,0	5,1	22,0	0,7	2X5	20
EI 30/18	1018N/1-2	10,4	18	14,6	19,5	26,7	12,3	7,0	5,1	22,0	0,7	2X5	20

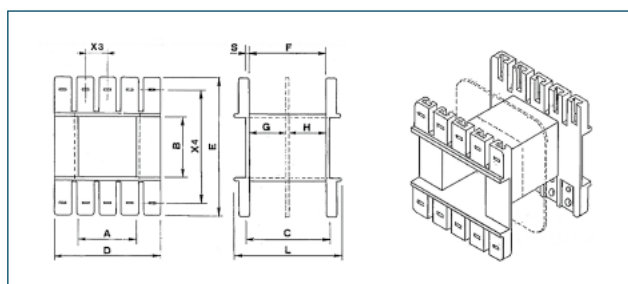

EI 48

Lam. 40X48

TYPE	REF.	a	b	c	d	e	f	g	h	x1	x2	x3	x4	GC	S	L	numero term.
EI 48/16	1616E/1-2	16,5	16,0	23,6	31,0	38,2	22,0	10,7	10,2			6,2	31,5		0,8	30,3	3x5 3x5
EI 48/20	1620E/1-2	16,5	20,0	23,6	31,0	42,0	22,0	10,7	10,2			6,2	36,5		0,8	30,5	3x5 3x5
EI 48/25	1625E/1-2	16,5	25,0	23,5	31,0	45,0	21,5	10,8	8,5			6,2	40,5		1,1	27,6	2x5 2x5

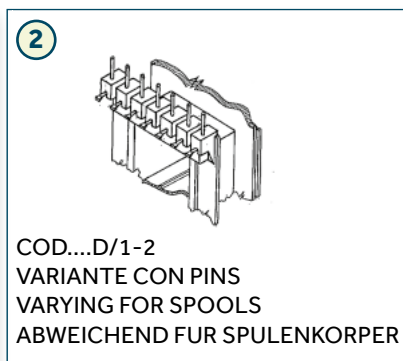
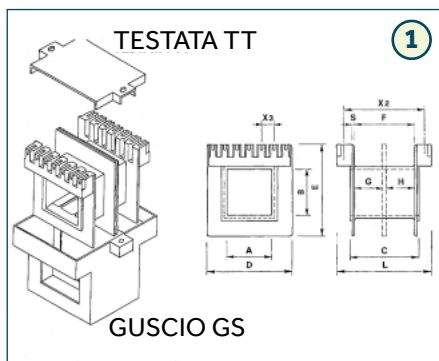

EI 54

Lam. 45X54

TYPE	REF.	a	b	c	d	e	f	g	h	x1	x2	x3	s	L	GS	TT	numero term.	disegno
EI 54/18	1818A/1-2	18,8	18,0	25,9	33,8	36,5	23,8	10,8	10,8	32,5	5,0	0,7	44,1	■	■		2x7	1
EI 54/18	1818D/1-2	18,8	18,0	25,9	33,8	36,5	23,8	10,8	10,8	32,5	5,0	0,7	44,1	■	■		2x7	2
EI 54/28	1828A/2	18,8	28,0	25,9	33,8	36,5	23,8	10,8	10,8	32,5	5,0	0,7	44,1	■			2x7	1

ROCCHETTI IN MATERIALE TERMOPLASTICO TIPO D

COIL FORMS IN THERMOPLASTIC MATERIAL

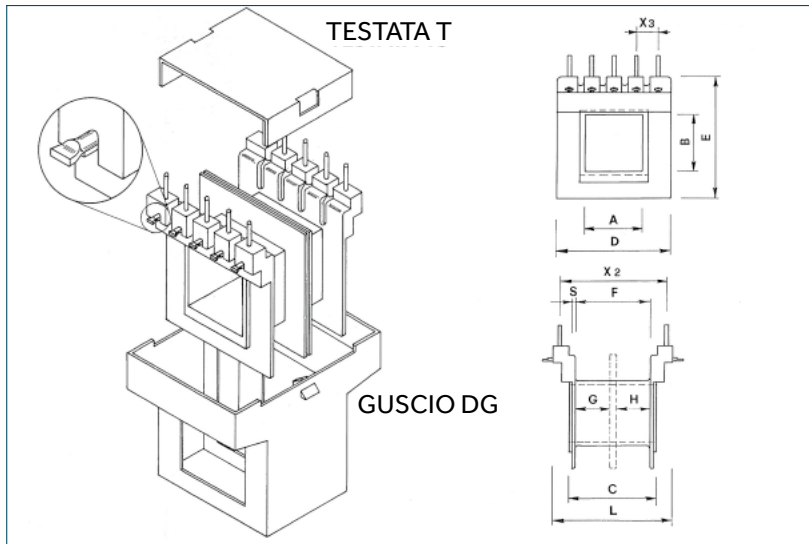

SCHEMA DI MONTAGGIO PINS (DA SPECIFICARE SU ORDINE ACQUISTO)

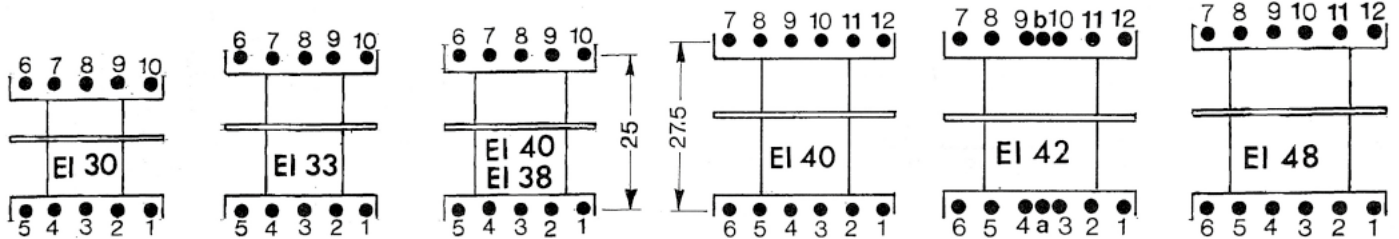

IL NUMERO "1" DI RIFERIMENTO È DA INTENDERSI DALLA PARTE DEL PRIMARIO (PIÙ LARGA)

TYPE	REF.	a	b	c	d	e	f	g	h	x2	x3	numero term.	DG	T
EI 30/10,5	1010D30/1-2	10,6	10,6	14,6	19,4	19,8	12,3	7,1	5,1	20,0	5	5	■	■
EI 30/12,5	1012D/1-2	10,6	12,6	14,6	19,4	21,8	12,3	7,1	5,1	20,0	5	5	■	■
EI 30/15	1015D30/1-2	10,6	15,6	14,6	19,4	24,8	12,3	7,1	5,1	20,0	5	5	■	■
EI 30/18	1018D30/1-2	10,6	18,1	14,6	19,4	27,4	12,3	7,1	5,1	20,0	5	5	■	■
EI 30/23	1023D/1-2	10,6	23,1	14,6	19,4	32,4	12,3	7,1	5,1	20,0	5	5	■	■
EI 33/10,5	1010D33/1-2	10,6	10,6	16,8	21,5	25,0	14,8	5,6	7,7	20,0	5	5	■	■
EI 33/13	1013D/1-2	10,6	13,1	16,8	21,5	28,0	14,8	5,6	7,7	20,0	5	5	■	■
EI 33/15	1015D33/1-2	10,6	15,6	16,8	21,5	30,0	14,8	5,6	7,7	20,0	5	5	■	■
EI 33/18	1018D33/1-2	10,6	18,1	16,8	21,5	32,5	14,8	5,6	7,7	20,0	5	5	■	■
EI 38/13	1313D/1-2	13,4	13,5	18,7	24,0	25,1	16,4	6,1	8,4	25,0	5	6	■	■
EI 38/15	1315D/1-2	13,4	15,0	18,7	24,0	27,3	16,4	6,1	8,4	25,0	5	6	■	■
EI 40/13	1313D25/1-2	13,4	13,4	19,7	25,4	28,9	17,5	6,6	9,1	25,0	5	5	■	■
EI 40/15	1315D27/1-2	13,4	15,4	19,7	25,4	30,9	17,5	6,6	9,1	27,5	5	6	■	■
EI 40/20	1320D27/1-2	13,4	20,4	19,7	25,4	35,9	17,5	6,6	9,1	27,5	5	6	■	■
EI 42/14	1414D/1-2	14,4	14,8	20,7	26,4	29,3	18,4	7,3	9,2	25,0	5	6	■	■
EI 42/18	1418D/1-2	14,4	18,8	20,7	26,4	29,3	18,4	7,3	9,2	25,0	5	6	■	■
EI 48/16	1616D/1-2	16,5	16,8	23,7	30,4	34,5	21,3	9,2	10,2	27,5	5	6	■	■
EI 48/20	1620D/1-2	16,5	20,5	23,7	30,4	38,2	21,3	9,2	10,2	27,5	5	6	■	■
EI 48/25	1625D/1-2	16,5	25,5	23,7	30,4	43,2	21,3	9,2	10,2	27,5	5	6	■	■

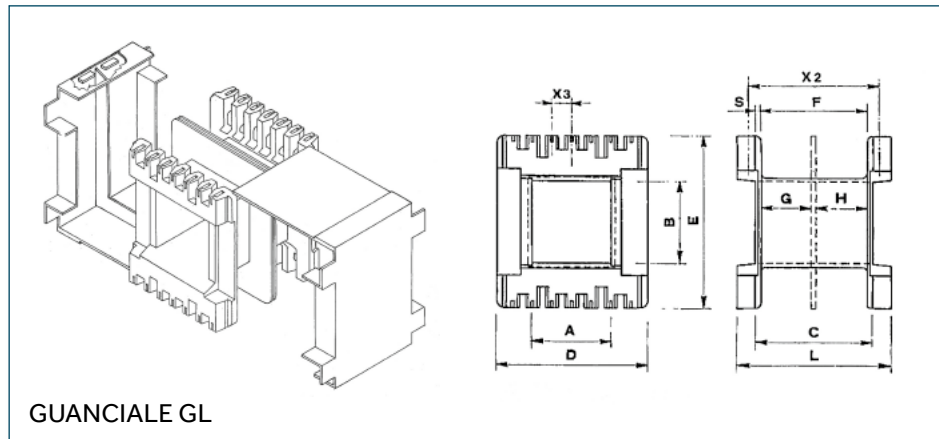

EI 60

Lam. 50X60

TYPE	REF.	a	b	c	d	e	f	g	h	x2	x3	s	L	GL	numero term.
EI 60/20	2020A/1-2	20,8	21,5	29,5	37,7	42,9	27,0	13,0	11,8	32,5	5,0	1,25	38,6	■	4X7
EI 60/25	2025A/1-2	20,8	25,5	29,5	37,7	46,9	27,0	13,0	11,8	32,5	5,0	1,25	38,6	■	4X7
EI 60/30	2030A/1-2	20,8	30,5	29,5	37,7	51,9	27,0	13,0	11,8	32,5	5,0	1,25	38,6	■	4X7
EI 60/35	2035A/1-2	20,8	35,5	29,5	37,7	56,9	27,0	13,0	11,8	32,5	5,0	1,25	38,6	■	4X7
EI 60/40	2040A/1-2	20,8	40,5	29,5	37,7	61,9	27,0	13,0	11,8	32,5	5,0	1,25	38,6	■	4X7
EI 60/45	2045A/1-2	20,8	45,5	29,5	37,7	66,9	27,0	13,0	11,8	32,5	5,0	1,25	38,6	■	3X7

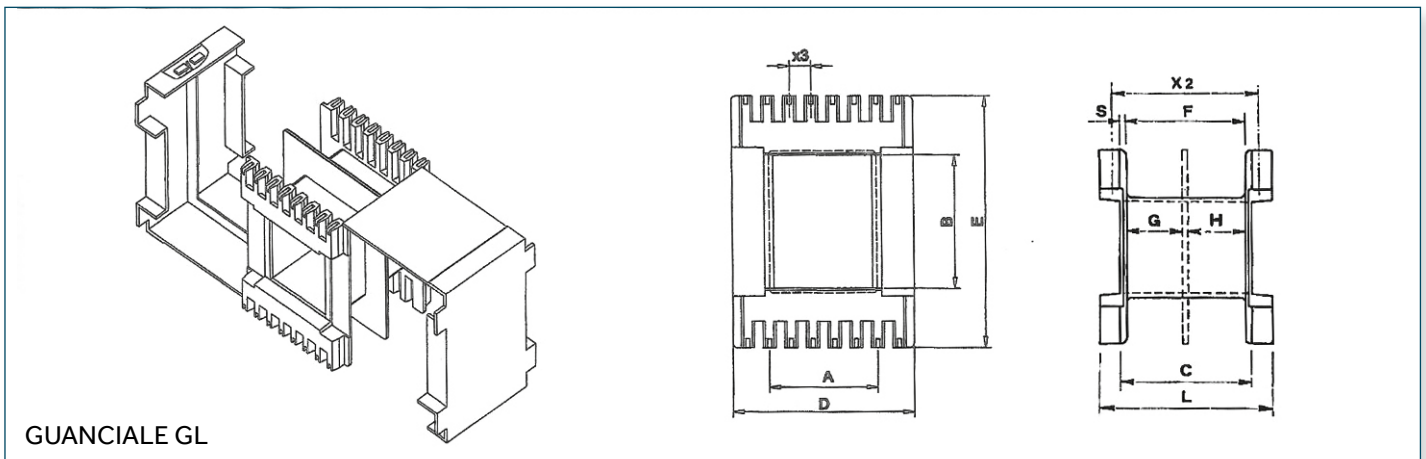

EI 66

Lam. 55X66

TYPE	REF.	a	b	c	d	e	f	g	h	x1	x2	x3	s	L	GL	G	numero term.
EI 66/22	2222A/1-2	22,8	22,5	32,5	41,8	50,2	29,8	13,5	14,5		35,0	5,0			■		4x8
EI 66/25	2225A/1-2	22,8	25,5	32,5	41,8	53,2	29,8	13,5	14,5		35,0	5,0			■		4x8
EI 66/30	2230A/1-2	22,8	30,5	32,5	41,8	58,2	29,8	13,5	14,5		35,0	5,0			■		4x8
EI 66/35	2235A/1-2	22,8	35,5	32,5	41,8	63,2	29,8	13,5	14,5		35,0	5,0			■		4x8
EI 66/40	2240A/1-2	22,8	40,5	32,5	41,8	68,2	29,8	13,5	14,5		35,0	5,0			■		4x8
EI 66/45	2245A/1-2	22,8	45,5	32,5	41,8	73,5	29,8	13,75	14,75		35,0	5,0			■		3x8
EI 66/55	2255A/2	22,8	55,5	32,5	41,8	83,5	29,8	13,75	14,75		35,0	5,0			■		3x8

NOTE: 1. SENZA FLANGIA INTERMEDIA
2. CON FLANGIA INTERMEDIA

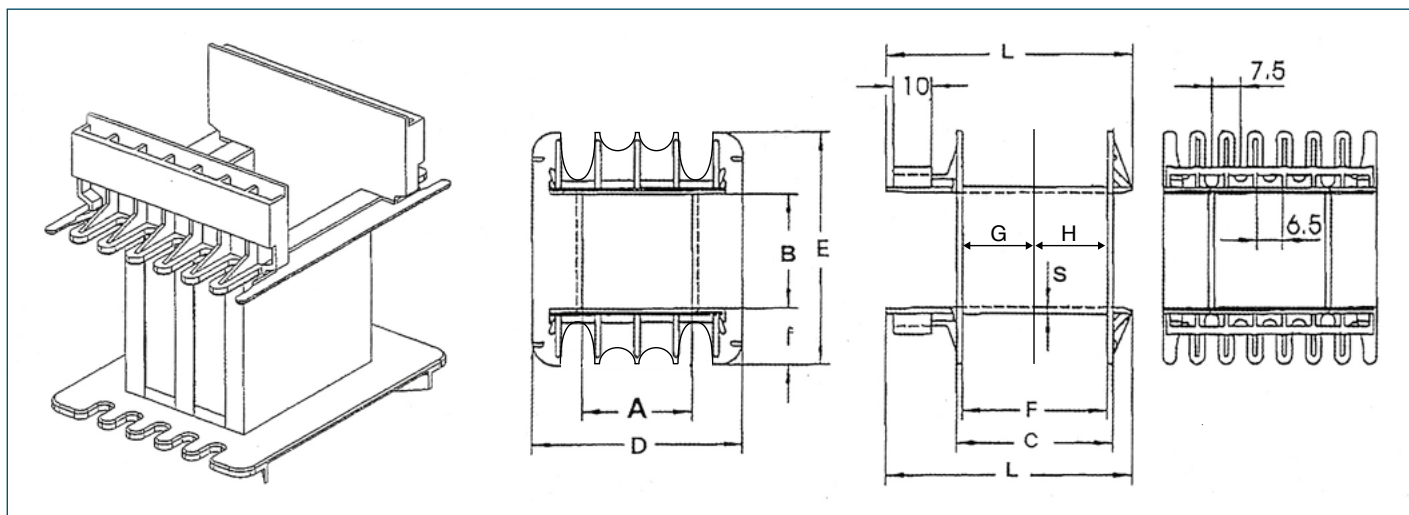

EI 75

Lam. 62,5X75

TYPE	REF.	a	b	c	d	e	f	g	h	x2	x3	GG	T	S	L	numero term.
EI 75/26,5	2526K/1	26,0	26,8	36,6	47,5	54,7	34,0	16,0	16,0					1,5	57,2	2x6
EI 75/32,7	2532K/1	26,0	33,0	36,6	47,5	61,0	34,0	16,0	16,0					1,5	57,2	2X6
EI 75/41,5	2541K/1	26,0	41,7	36,6	47,5	69,6	34,0	16,0	16,0					1,5	57,2	2X6

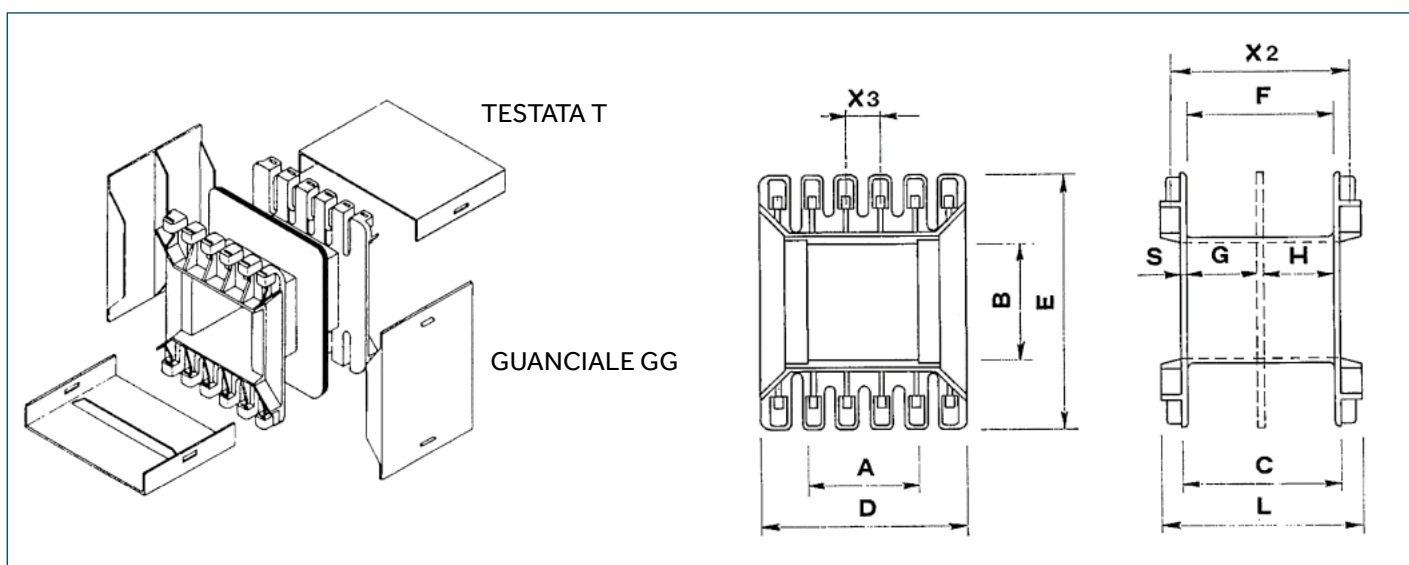

EI 75

Lam. 62,5X75

TYPE	REF.	a	b	c	d	e	f	g	h	x2	x3	GG	T	S	L	numero term.
EI 75/20	2520F/1-2	25,8	20,8	37	47,5	50,7	34,0	14,0	18,0	42,5	7,65			1,5	46,2	4x6
EI 75/25	2525F/1-2	25,8	25,8	37	47,5	55,7	34,0	14,0	18,0	42,5	7,95	■	■	1,5	46,2	4x6
EI 75/30	2530F/1-2	25,8	30,8	37	47,5	60,7	34,0	14,0	18,0	42,5	7,95	■	■	1,5	46,2	4x6
EI 75/35	2535F/1-2	25,8	35,8	37	47,5	65,7	34,0	14,0	18,0	42,5	7,95	■	■	1,5	46,2	4x6
EI 75/40	2540F/1-2	25,8	40,8	37	47,5	70,7	34,0	14,0	18,0	42,5	7,95	■	■	1,5	46,2	4x6

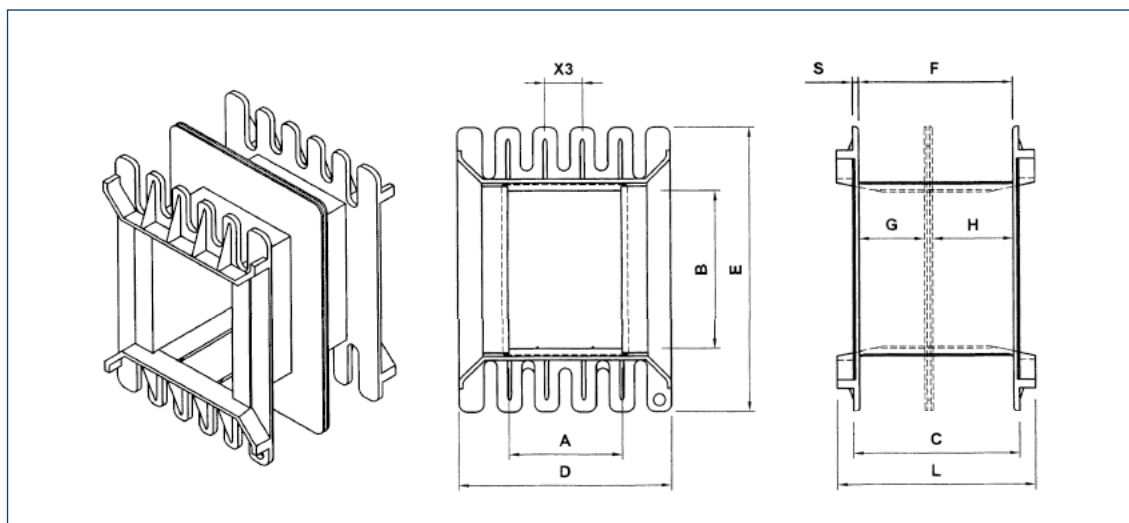

EI 75

Lam. 62,5X75

TYPE	REF.	a	b	c	d	e	f	g	h	s	L	GG	T
EI 75/25	2525VA/1-2	25,8	25,0	37	47,5	55,0	34,0	18,0	14	1,6	46,2		
EI 75/30	2530VA/1-2	25,8	30,0	37	47,5	60,0	34,0	18,0	14	1,6	46,2		
EI 75/35	2535VA/1-2	25,8	35,0	37	47,5	65,0	34,0	18,0	14	1,6	46,2		
EI 75/40	2540VA/1-2	25,8	40,0	37	47,5	70,0	34,0	18,0	14	1,6	46,2		

- Do you have a project?
- Would you like proposal?
- Are you planning a large production and you want to amortize moulds?

➔ **CONSULT US!**

ROCCHETTI IN MATERIALE TERMOPLASTICO

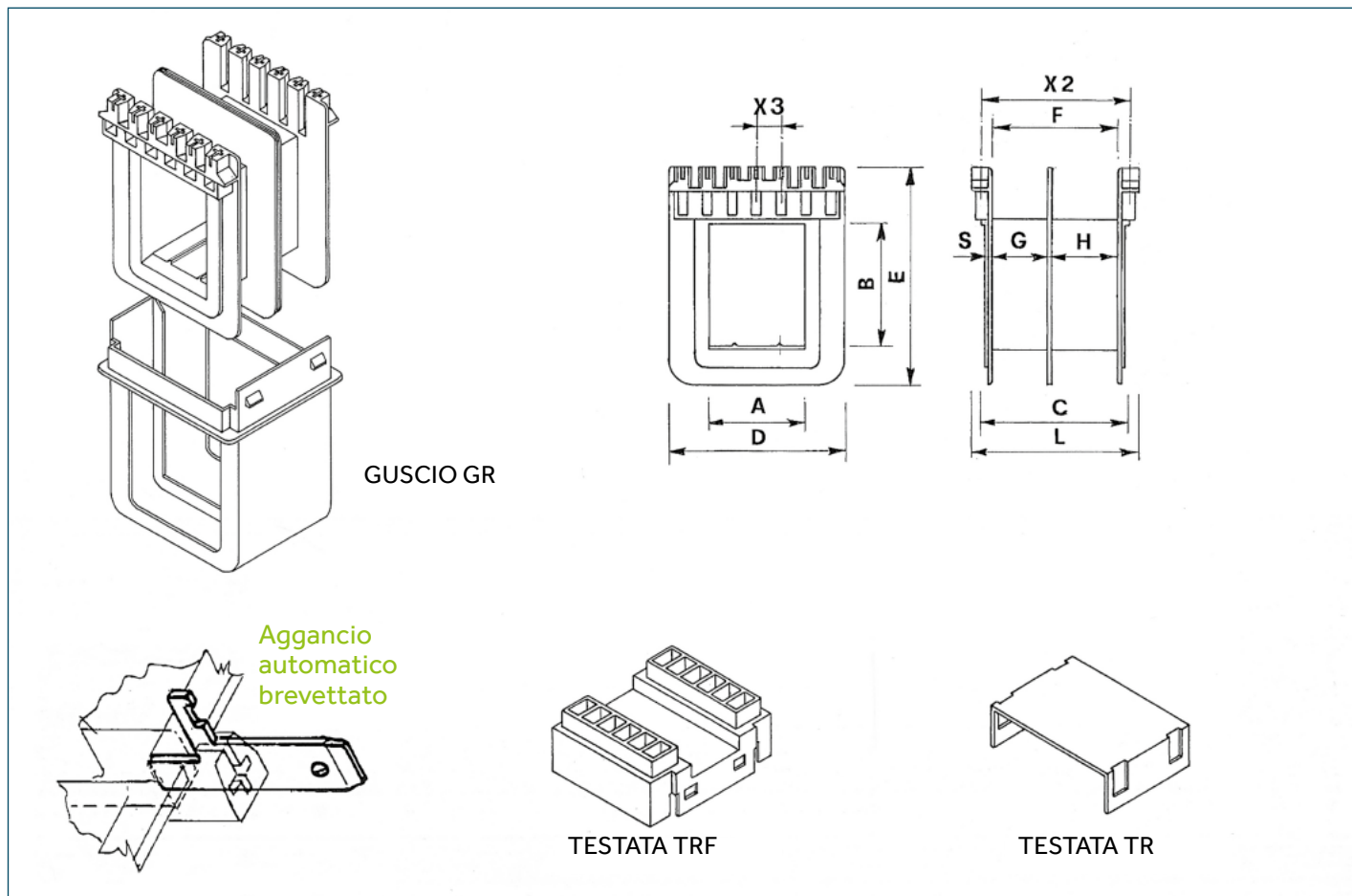

EI 75

Lam. 62,5X75

TYPE	REF.	a	b	c	d	e	f	g	h	x2	x3	numero term.	GR	TR	TRF
EI 75/25	2525R/1-2	25,8	25,6	37,1	48,2	52,0	34,4	18,5	14,0	39,0	7,5	6	■	■	■
EI 75/30	2530R/1-2	25,8	30,6	37,1	48,2	57,0	34,4	18,5	14,0	39,0	7,5	6	■	■	■
EI 75/35	2535R/1-2	25,8	35,6	37,1	48,2	62,0	34,4	18,5	14,0	39,0	7,5	6	■	■	■
EI 75/35	2535R/2A	25,8	35,6	37,1	48,2	62,0	34,4	25,5	7,0	39,0	7,5	6	■	■	■
EI 75/40	2540R/1-2	25,8	40,6	37,1	48,2	67,0	34,4	18,5	14,0	39,0	7,5	6	■	■	■
EI 75/40	2540R/2A	25,8	40,6	37,1	48,2	67,0	34,4	25,5	7,0	39,0	7,5	6	■	■	■

EI 84

Lam. 70X84

TYPE	REF.	a	b	c	d	e	f	g	h	x2	x3	numero term.	GR	TR	TRF
EI 84/28	2828R/1-2	28,8	28,2	41,6	53,6	56,5	38,0	19,3	16,6	45,0	7,5	7	■	■	■
EI 84/30	2830R/1-2	28,8	30,2	41,6	53,6	58,8	38,0	19,3	16,6	45,0	7,5	7	■	■	■
EI 84/35	2835R/1-2	28,8	35,2	41,6	53,6	63,8	38,0	19,3	16,6	45,0	7,5	7	■	■	■
EI 84/40	2840R/1-2	28,8	40,2	41,6	53,6	68,8	38,0	19,3	16,6	45,0	7,5	7	■	■	■
EI 84/43	2843R/1-2	28,8	43,2	41,6	53,6	71,8	38,0	19,3	16,6	45,0	7,5	7	■	■	■
EI 84/43	2843R/2A	28,8	43,2	41,6	53,6	71,8	38,0	28,9	7,0	45,0	7,5	7	■	■	■
EI 84/43	2843R/2C	28,8	43,2	41,6	53,6	71,8	38,0	17,9	17,9	45,0	7,5	7	■	■	■
EI 84/50	2850R/1-2	28,8	50,2	41,6	53,6	78,8	38,0	19,3	16,6	45,0	7,5	7	■	■	■
EI 84/55	2855R/1-2	28,8	55,2	41,6	53,6	83,8	38,0	19,3	16,6	45,0	7,5	7	■	■	■

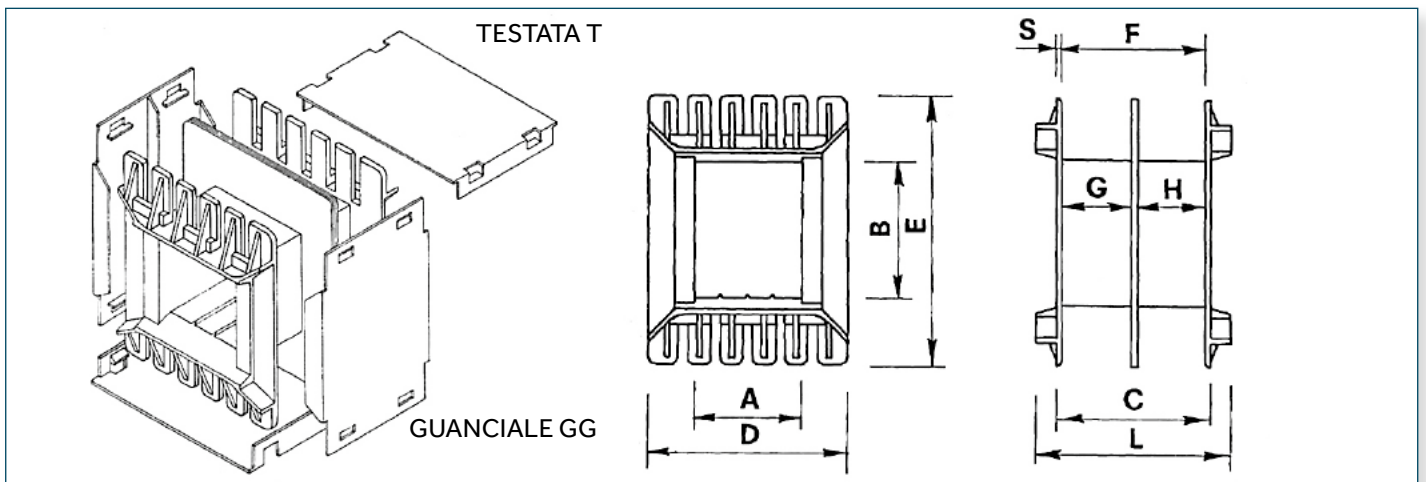

EI 84

Lam. 70X84

TYPE	REF.	a	b	c	d	e	f	g	h	S	GG	T	L
EI 84/21	2821V/1-2	28,8	21,8	41,5	53,2	53,0	38,5	20	16,5	1,6			49,5
EI 84/28	2828V/1-2	28,8	28,8	41,5	53,2	59,0	38,5	20	16,5	1,6			49,5
EI 84/30	2830G/1-2	28,8	30,8	41,5	53,2	62,0	38,5	20	16,5	1,6	■	■	49,5
EI 84/35	2835G/1-2	28,8	35,8	41,5	53,2	67,0	38,5	20	16,5	1,6	■	■	49,5
EI 84/40	2840G/1-2	28,8	40,8	41,5	53,2	72,0	38,5	20	16,5	1,6	■	■	49,5
EI 84/43	2843VA/1-2	28,8	43,8	41,5	53,2	73,0	38,5	18,5	18,5	1,6			49,5
EI 84/45	2845VA/1-2	28,8	45,8	41,5	53,2	77,0	38,5	20	16,5	1,6			49,5
EI 84/50	2850G/1-2	28,8	50,8	41,5	53,2	82,0	38,5	20	16,5	1,5	■	■	49,5

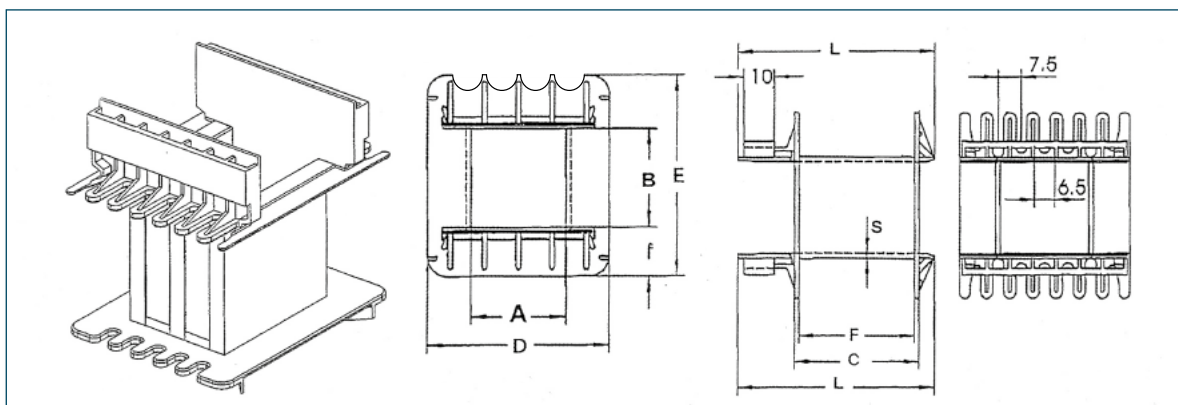

EI 84

Lam. 70X84

TYPE	REF.	a	b	c	d	e	f	g	h	x2	x3	S	L	numero term.
EI 84/29,5	2829K/1	28,7	29,5	41,3	55,1	60,0	38,0					1,5	64,5	2X7
EI 84/38	2838K/1	28,7	38,8	41,3	55,1	69,3	38,0					1,5	64,5	2X7
EI 84/41	2841K/1	28,7	41,5	41,3	55,1	74,0	38,0					1,5	64,5	2X7
EI 84/43	2843K/1	28,7	43,5	41,3	55,1	76,0	38,0					1,5	64,5	2X7
EI 84/50	2850K/1	28,7	51,0	41,3	55,1	82,5	38,0					1,5	64,5	2X7

ROCCHETTI IN MATERIALE TERMOPLASTICO

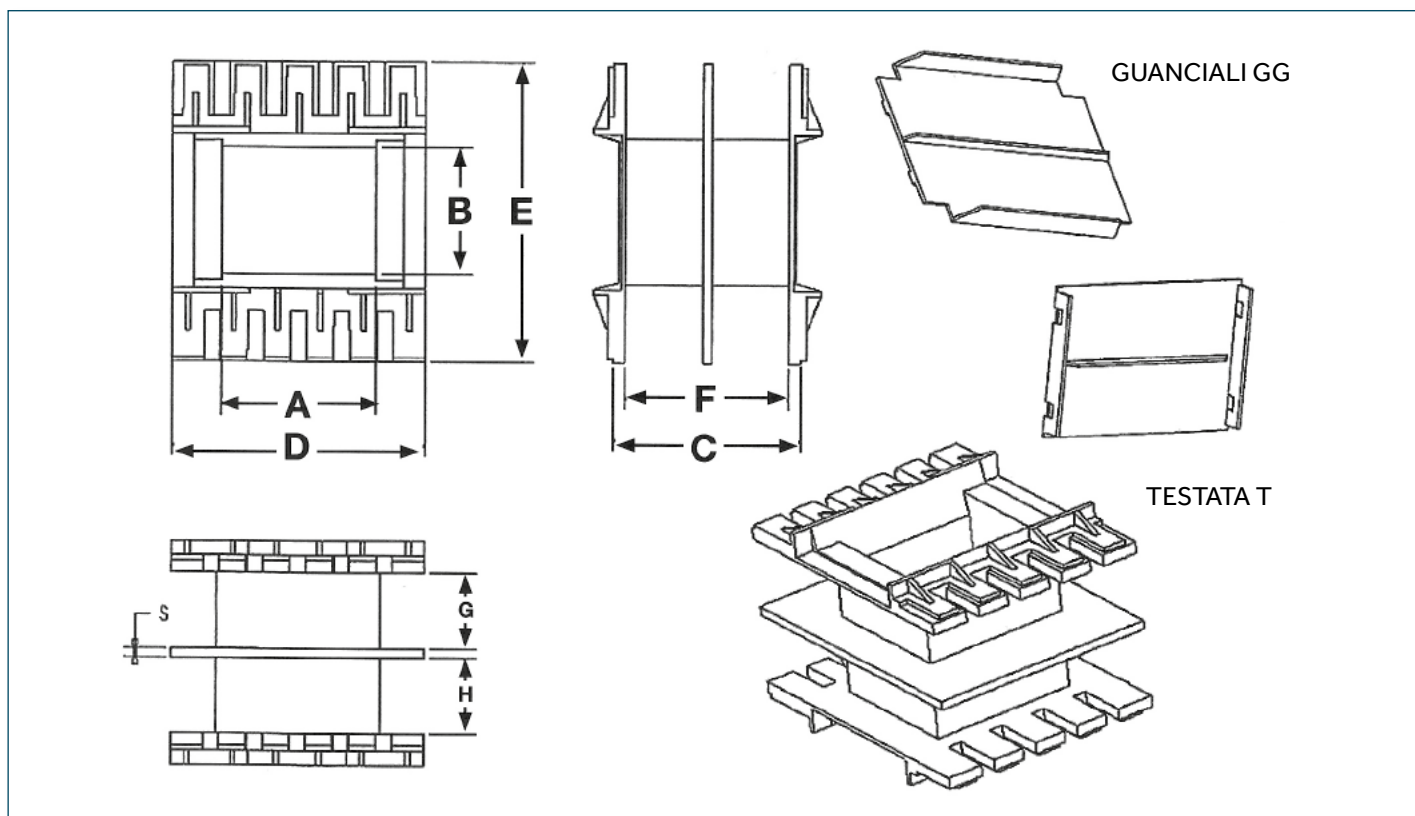

indicatori rochetti modello E-T

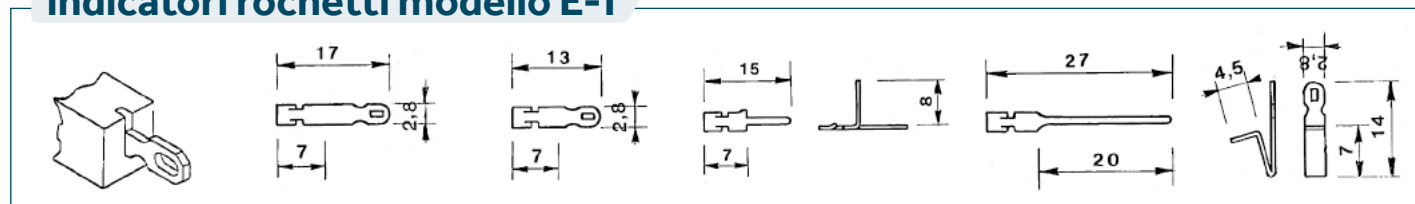

EI 84

Lam. 70X84

TYPE	REF.	a	b	d	e	c	f	g	h	s	GG
EI 84/29	2830T/1-2	28,8	31,0	53,8	64,2	41,6	38,2	16,5	19,5	2,2	
EI 84/29	2830GG/1-2										■
EI 84/35	2835T/1-2	28,8	35,2	53,8	70,2	41,6	38,2	16,5	19,5	2,2	
EI 84/35	2835GG/1-2										■
EI 84/40	2840T/1-2	28,8	41,0	53,8	75,2	41,6	38,2	16,5	19,5	2,2	
EI 84/40	2840GG/1-2										■
EI 84/45	2845TT/1-2	28,8	45,2	53,8	80,2	41,6	38,2	16,5	19,5	2,2	
EI 84/45*	2845GGT/1-2										■
EI 84/50	2850T/1-2	28,8	50,2	53,8	85,2	41,6	38,2	16,5	19,5	2,2	
EI 84/50	2850GG/1-2										■
EI 84	28T/1-2	TESTATA COL 28									
EI 84*	28TT/1-2	TESTATA SOLO PER 2845 T/1-2									

Avvertenza importante - Precisiamo

Le carte gialle sono valide solo se chi stampa ha il certificato UL.

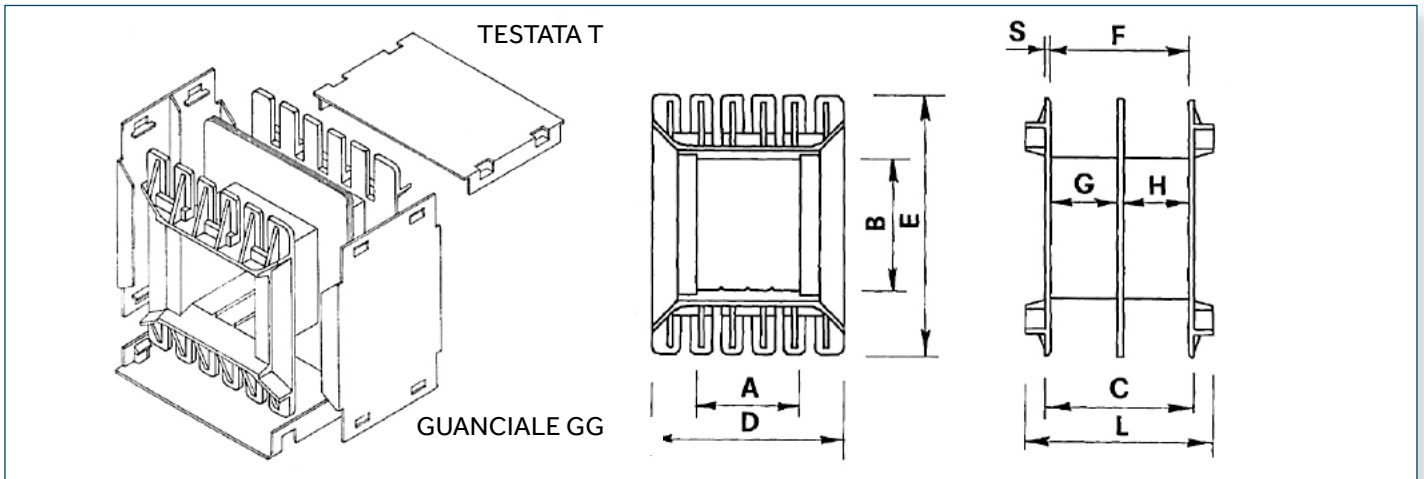

EI 96

Lam. 80X96

TYPE	REF.	a	b	c	d	e	f	g	h	GG	T	S	L
EI 96/32	3232G/1-2	33,0	32,8	47,35	60,9	71,5	44,0	21,0	21,0	■	■	1,55	57,1
EI 96/35	3235G/1-2	32,7	35,9	47,35	60,7	74,5	44,0	21,0	21,0	■	■	1,55	57,1
EI 96/40	3240G/1-2	32,6	40,8	47,35	60,6	79,3	43,7	21,0	21,0	■	■	1,55	56,7
EI 96/45	3245G/1-2	32,6	45,6	47,35	60,7	84,3	43,7	21,0	21,0	■	■	1,55	55,5
EI 96/50	3250G/1-2	32,6	50,6	47,35	60,8	89,5	43,5	21,0	21,0	■	■	1,55	56,6
EI 96/55	3255VA/1-2	32,6	55,8	47,35	60,8	94,5	43,6					1,55	56,6
EI 96/60	3260G/1-2	32,6	60,8	47,35	60,8	99,1	43,7	20,6	20,6	■	■	1,55	56,8
EI 96/70	3270G/1-2	32,8	70,8	47,35	60,8	109,5	44,2	21,0	21,0	■	■	1,55	56,5

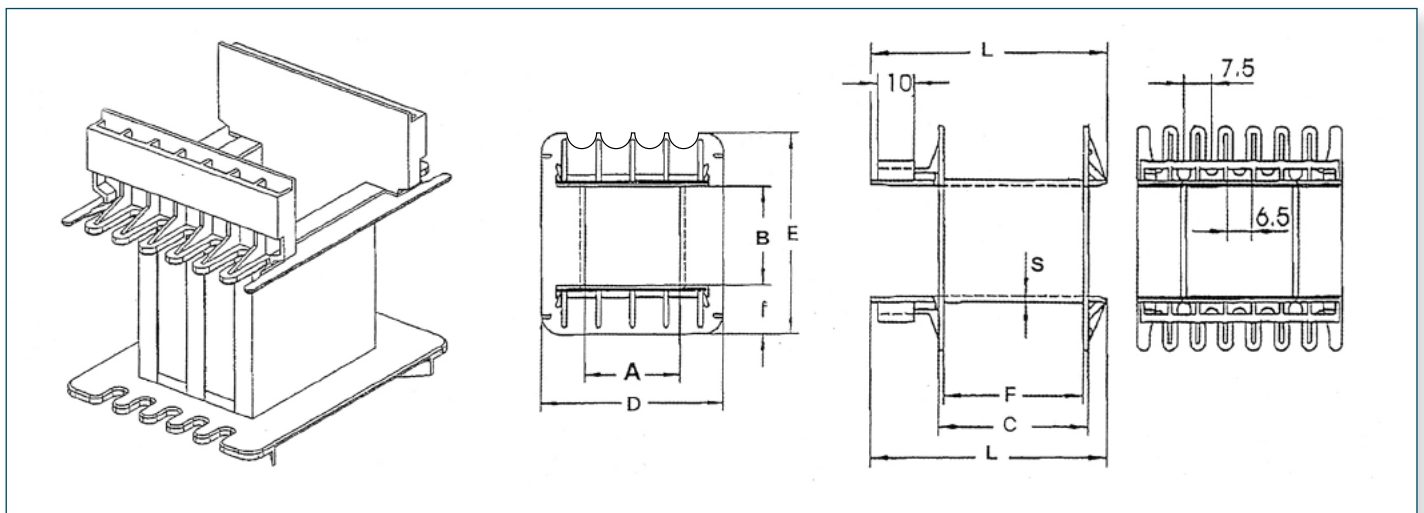

EI 96

Lam. 80X96

TYPE	REF.	a	b	c	d	e	f	GG	T	s	L	numero term.
EI 96/35	3235K/1	32,7	35,7	47,2	62,5	70,3	44,0			1,55	71,3	2x8
EI 96/45	3245K/1	32,7	45,7	47,2	62,5	80,3	44,0			1,55	71,3	2x8
EI 96/50	3250K/1	32,7	50,7	47,2	62,5	85,3	44,0			1,55	71,3	2x8
EI 96/60	3260K/1	32,7	59,7	47,2	62,5	94,3	44,0			1,55	71,3	2x8

NOTE: 1. SENZA FLANGIA INTERMEDIA
2. CON FLANGIA INTERMEDIA

ROCCHETTI IN MATERIALE TERMOPLASTICO

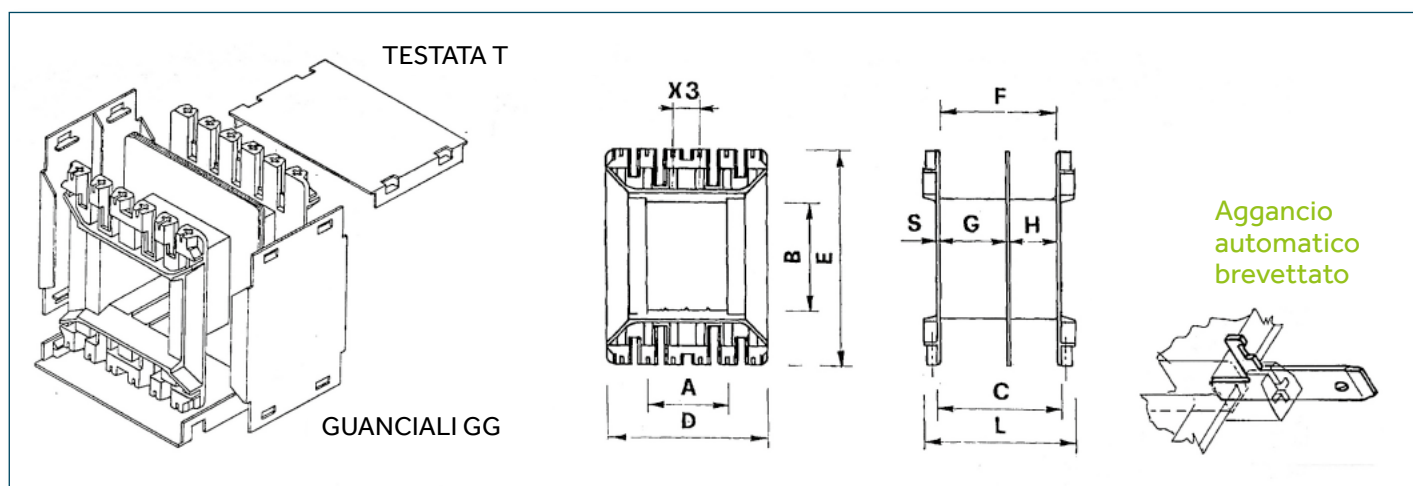

EI 96

Lam. 80X96

TYPE	REF.	a	b	c	d	e	f	g	h	x3	GG	T	S	L	numero term.
EI 96/32	3232R/1-2	33,0	32,8	47,35	60,9	71,5	44,0	21,0	21,0	10,0	■	■	1,55	57,1	4x6
EI 96/35	3235R/1-2	32,7	35,9	47,35	60,7	74,5	44,0	21,0	21,0	10,0	■	■	1,55	57,1	4x6
EI 96/40	3240R/1-2	32,6	40,8	47,35	60,6	79,3	43,7	21,0	21,0	10,0	■	■	1,55	56,7	4x6
EI 96/45	3245R/1-2	32,6	45,6	47,35	60,7	84,3	43,7	21,0	21,0	10,0	■	■	1,55	55,5	4x6
EI 96/50	3250R/1-2	32,6	50,6	47,35	60,8	89,5	43,5	21,0	21,0	10,0	■	■	1,55	56,6	4x6
EI 96/60	3260R/1-2	32,5	60,8	47,35	60,8	99,1	43,7	20,6	20,6	10,0	■	■	1,55	56,8	4x6
EI 96/70	3270R/1-2	32,8	70,8	47,35	60,8	109,5	44,2	21,0	21,0	10,0	■	■	1,55	56,5	4x6

IN EUROPA...

- 7 aziende producono rocchetti mono/trifase
- 7 aziende producono staffe e angolari in ferro
- 6 aziende producono morsetti
- 6 aziende hanno le certificazioni
- 4 aziende producono accessori per toroidali
- 4 aziende lavorano carte e adesivi dielettrici
- 4 aziende producono minuterie metalliche
- 2 aziende producono angolari in plastica
- 2 aziende producono rocchetti in cartone
- 2 aziende producono rocchetti per nuclei "C"

Una sola azienda produce e vende tutti questi articoli...

→ **CieRre**

20 ARTICOLI UN SOLO TRASPORTO

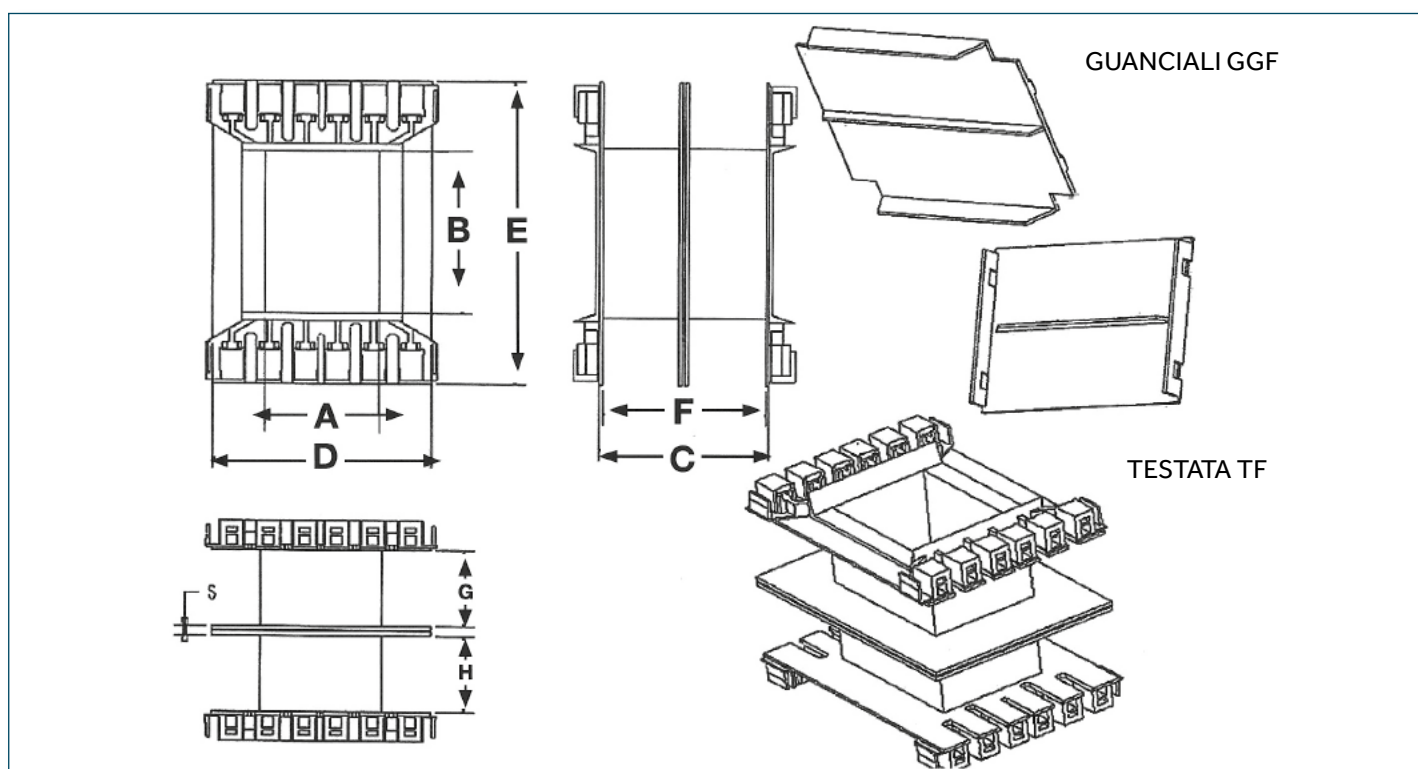

indicatori rochetti modello F

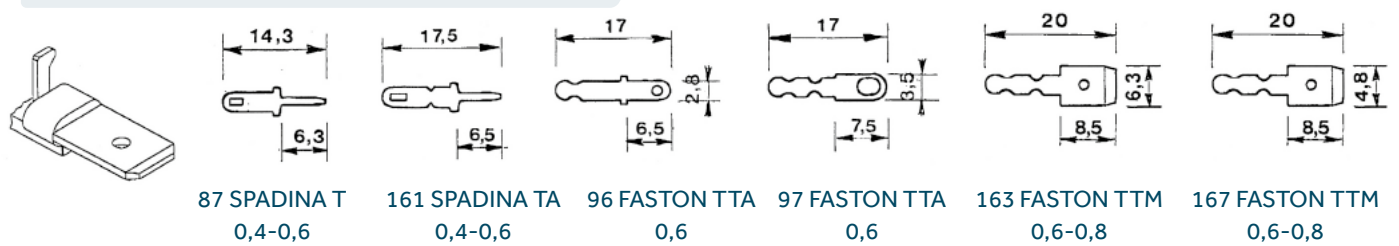

EI 96

Lam. 80X96

TYPE	REF.	a	b	d	e	c	f	g	h	s
EI 96/32	3232F/1-2	32,6	32,8	61,0	71,6	47,0	44,3	21,0	21,0	2,3
EI 96/32	3232GGF/1-2	GUANCIALE								
EI 96/40	3240F/1-2	32,6	40,8	61,0	79,6	47,0	44,3	21,0	21,0	2,3
EI 96/40	3240GGF/1-2	GUANCIALE								
EI 96/45	3245F/1-2	32,6	45,8	61,0	84,6	47,0	44,3	21,0	21,0	2,3
EI 96/45	3245GGF/1/2	GUANCIALE								
EI 96/50	3250F/1-2	32,6	50,8	61,0	89,6	47,0	44,3	21,0	21,0	2,3
EI 96/50	3250GGF/1-2	GUANCIALE								
EI 96/60	3260F/1-2	32,6	60,8	61,0	99,6	47,0	44,3	21,0	21,0	2,3
EI 96/60	3260GGF/1-2	GUANCIALE								
EI 96	32TF/1-2	TESTATA COL 32								

Avvertenza importante - Precisiamo

Le carte gialle sono valide solo se chi stampa ha il certificato UL (che certifica).

ROCCHETTI IN MATERIALE TERMOPLASTICO

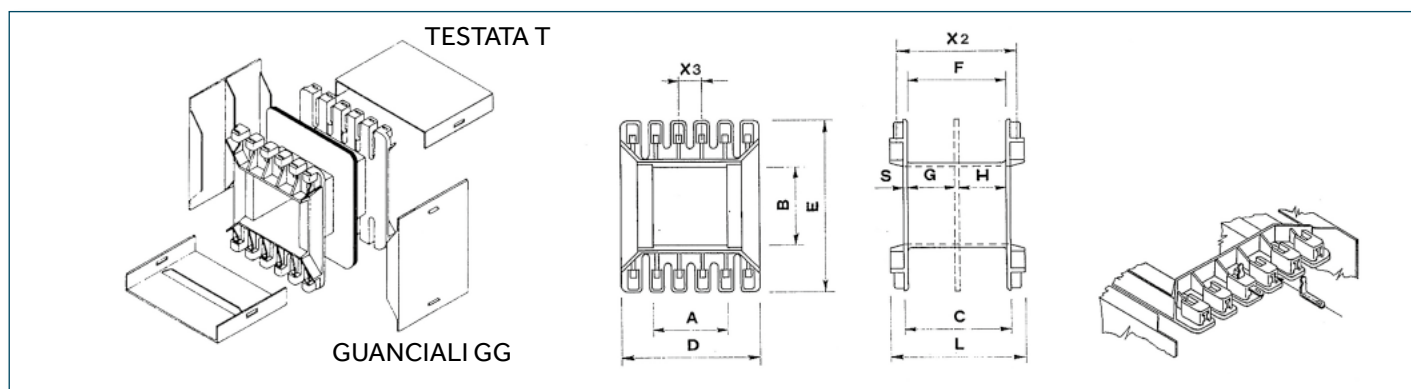

EI 108

Lam. 90X108

TYPE	REF.	a	b	c	d	e	f	g	h	x2	x3	GG	T	S	L	numero term.
EI 108/38	3638F/1-2	36,8	38,0	53,2	69,5	79,5	49,1	23,5	23,5	62,0	10,16	■	■	1,7	65,3	4x7
EI 108/45	3645F/1-2	36,8	45,5	53,1	69,5	86,8	49,1	23,5	23,5	62,0	10,16	■	■	1,7	65,8	4x7
EI 108/50	3650F/1-2	36,8	50,5	53,2	69,5	92,0	49,1	23,5	23,5	62,0	10,16	■	■	1,7	65,4	4x7
EI 108/55	3655F/1-2	36,8	55,5	53,1	69,5	96,7	49,1	23,5	23,5	62,0	10,16	■	■	1,7	65,4	4x7
EI 108/60	3660F/1-2	36,8	60,5	53,1	69,5	102,0	49,1	23,5	23,5	62,0	10,16	■	■	1,7	65,4	4x7

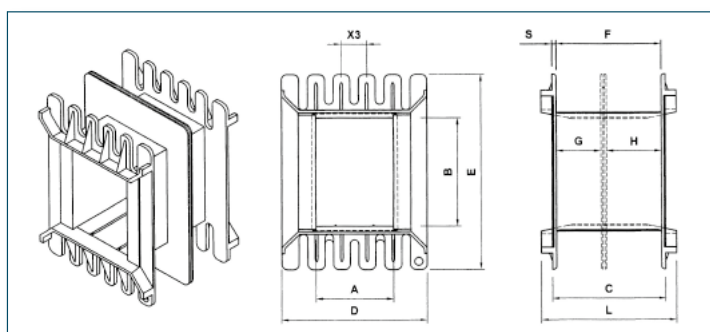

EI 108

Lam. 90X108

TYPE	REF.	a	b	c	d	e	f	g	h	S	L
EI 108/36	3636VA/1	36,7	37,0	52,7	70,8	79,3	49,0			1,7	60,7
EI 108/42	3642VA/1	36,8	42,8	52,7	70,8	85,3	49,0			1,7	60,5
EI 108/45	3645VA/1	36,8	45,8	52,7	70,8	88,3	49,0			1,5	60,5
EI 108/50	3650VA/1-2	36,8	51,0	52,7	70,8	93,3	48,8	25,5	22,5	1,7	60,4
EI 108/55	3655VA/1	36,8	55,2	53,5	71,2	98,3	49,0			1,7	60,5
EI 108/60	3660VA/1-2	36,8	60,3	52,5	71,0	104,0	49,0	25,5	22,5	1,7	60,5
EI 108/72	3672VA/1	36,8	72,3	51,0	68,8	104,3	46,8			1,7	60,5

EI 114

Lam. 95X114

TYPE	REF.	a	b	c	d	e	f	g	h	S	L
EI 114/38	3838V/1-2	38,8	38,0	57,0	75,0	80,0	54,5	27,0	25,0	1,5	65,0
EI 114/44	3844V/1-2	38,8	44,0	57,0	75,0	87,0	54,5	27,0	25,0	1,5	65,0
EI 114/50	3850V/1-2	38,8	50,0	57,0	75,0	94,0	54,5	27,0	25,0	1,5	65,0
EI 114/60	3860V/1-2	38,8	60,0	57,0	75,0	103,0	54,5	27,0	25,0	1,5	65,0
EI 114/76	3876V/1-2	38,8	76,0	57,0	75,0	121,0	54,5	27,0	25,0	1,5	65,0

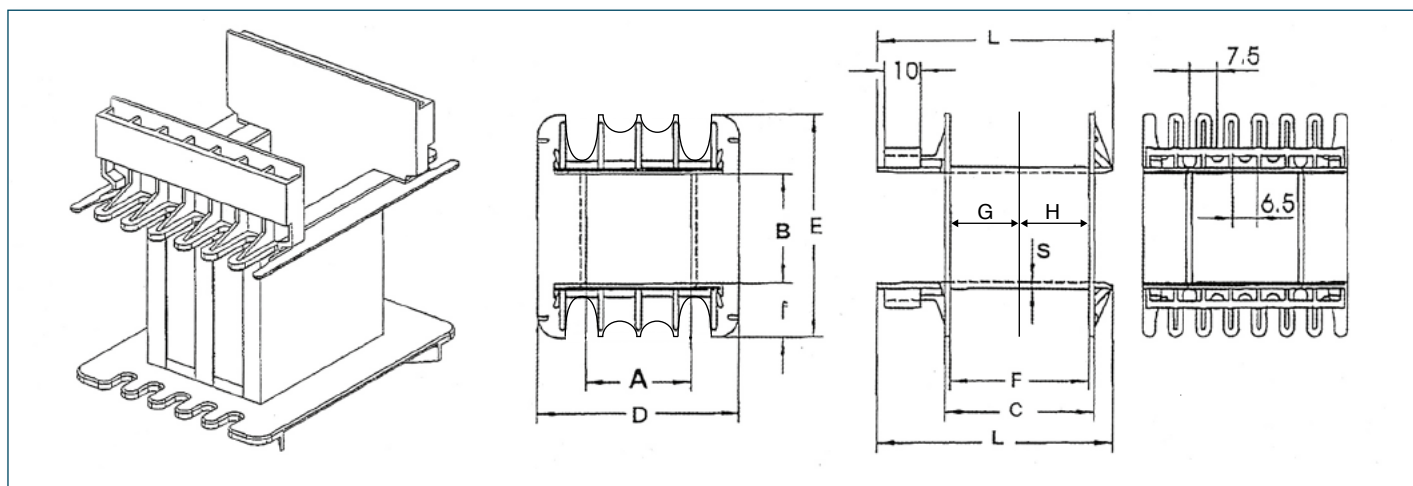

EI 108

Lam. 90X108

TYPE	REF.	a	b	c	d	e	f	s	L	numero term.
EI 108/38	3638K/1	37	38,7	53,0	69,5	78,5	49,3	1,7	78,4	2x9
EI 108/45	3645K/1	37	45,7	53,0	69,5	85,5	49,3	1,7	78,4	2x9
EI 108/50	3650K/1	37	50,7	53,0	69,5	90,5	49,3	1,7	78,4	2x9
EI 108/60	3660K/1	37	60,7	53,0	69,5	100,5	49,3	1,7	78,4	2x9

EI 120

Lam. 100X120

TYPE	REF.	a	b	c	d	e	f	g	h	s	L	numero term.
EI 120/41	4041K/1	41,3	42,4	59,4	77,0	88,3	56,0	27	27	1,8	85,6	2x10
EI 120/53	4053K/1	41,3	54,0	59,4	77,0	100,8	56,0	27	27	1,8	85,6	2x10
EI 120/61	4061K/1	41,3	62,2	59,4	77,0	109,0	56,0	27	27	1,8	85,6	2x10
EI 120/73	4073K/1	41,3	74,2	59,4	77,0	121,0	56,0	27	27	1,8	85,6	2x10



Oltre 15000
spedizioni annue
in 35 nazioni



ROCCHETTI IN MATERIALE TERMOPLASTICO

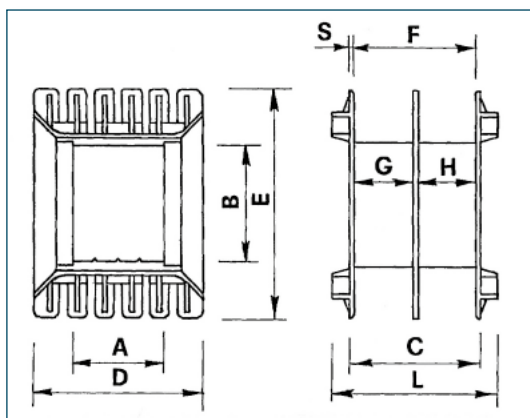
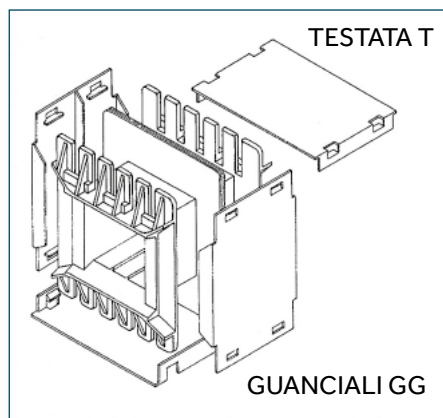

VARIANTE FLANGIA LISCIA (■)

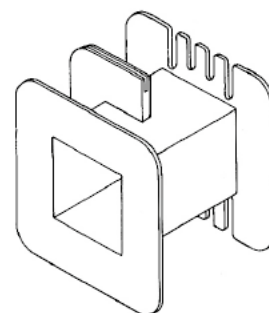

EI 120

Lam. 100X120

TYPE	REF.	a	b	c	d	e	f	g	h	GG	Tz	S	L	z1	x4	numero term.	variante flangia liscia
EI120/30	4030G/1-2	41,5	30,5	58,7	77,0	75,0	56,0	26,5	26,5	■	■	1,7	65,0				
EI 120/35	4035G/1-2	41,5	35,5	58,7	77,0	80,0	56,0	26,5	26,5	■	■	1,7	65,0				
EI 120/40	4040G/1-2	41,5	40,5	58,7	77,0	85,0	56,0	26,5	26,5	■	■	1,7	65,0				■
EI 120/45	4045G/1-2	41,5	45,5	58,7	77,0	90,0	56,0	26,5	26,5	■	■	1,7	65,0				
EI 120/50	4050G/1-2	41,5	50,5	58,7	77,0	95,0	56,0	26,5	26,5	■	■	1,7	65,0				■
EI 120/55	4055G/1-2	41,5	55,5	58,7	77,0	100,0	56,0	26,5	26,5	■	■	1,7	65,0				
EI 120/60	4060G/1-2	41,5	60,5	58,7	77,0	105,0	56,0	26,5	26,5	■	■	1,7	65,0				■
EI 120/65	4065G/1-2	41,5	65,5	58,7	77,0	110,0	56,0	26,5	26,5	■	■	1,7	65,0				
EI 120/70	4070G/1-2	41,5	71,5	58,7	77,0	115,5	56,0	26,5	26,5	■	■	1,7	65,0				■
EI 120/80	4080G/1-2	41,5	81,5	58,7	77,0	125,5	56,0	26,5	26,5	■	■	1,7	65,0				

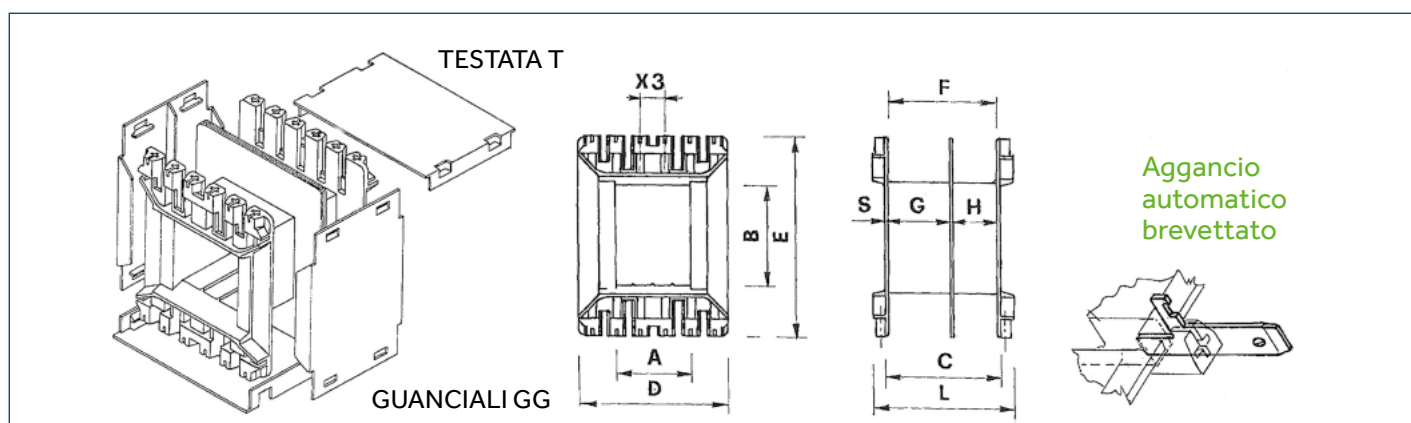

EI 120

Lam. 100X120

TYPE	REF.	a	b	c	d	e	f	g	h	x1	x3	S	L	GG	T	numero term.
EI 120/50	4050R/1-2	41,0	50,8	59,2	77,0	97,0	55,6	26,5	26,5		10,16	1,7	65,0	■	■	4x7
EI 120/55	4055R/1-2	41,0	55,8	59,2	77,0	102,0	55,6	26,5	26,5		10,16	1,7	65,0	■	■	4x7
EI 120/60	4060R/1-2	41,0	60,8	59,2	77,0	107,0	55,6	26,5	26,5		10,16	1,7	65,0	■	■	4x7

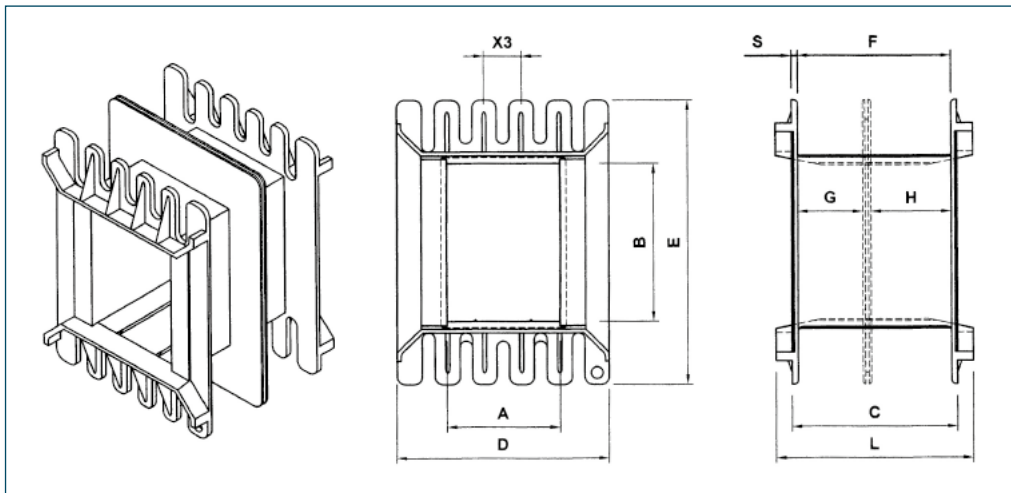

EI 126

Lam. 105X126

TYPE	REF.	a	b	c	d	e	f	g	h	s	L	GG	T
EI 126/43	4243G/1-2	43,1	43,0	62,3	81,6	89,6	58,3	28,0	28,0	1,60	71,0		
EI 126/50	4250G/1-2	43,2	50,0	62,3	81,6	97,6	58,3	28,0	28,0	1,60	71,0		
EI 126/60	4260G/1-2	43,2	60,0	62,3	81,6	107,6	58,3	28,0	28,0	1,60	71,0		
EI 126/70	4270G/1-2	43,3	70,0	62,3	81,6	117,6	58,3	28,0	28,0	1,55	71,0		
EI 126/80	4280G/1-2	43,3	80,0	62,3	81,6	127,6	58,3	28,0	28,0	1,55	71,0		

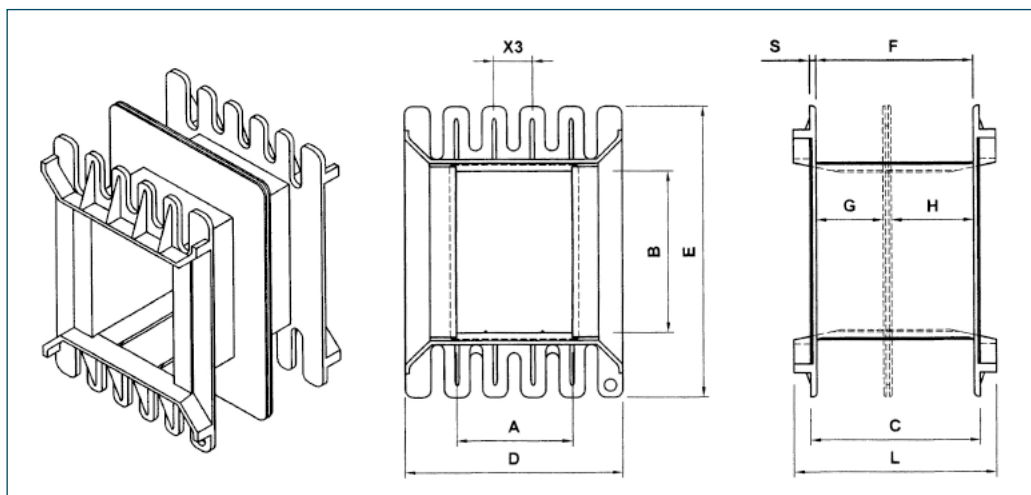

EI 135

Lam. 112,5X135

TYPE	REF.	a	b	c	d	e	f	g	h	x1	x2	x3	S	L
EI 135/45	4545V/1-2	45,7	45	66,6	89,0	100,0	63,0	31,6	28,2				1,8	72,0
EI 135/60	4560V/1-2	45,7	60	66,6	89,0	115,0	63,0	31,6	28,2				1,8	72,0
EI 135/70	4570V/1	45,7	70	66,6	89,0	125,0	63,0						1,8	72,0
EI 135/85	4585V/1	45,8	85	66,6	89,0	140,0	63,0						1,8	75,0
EI 135/90	4590V/1	45,7	90	66,6	89,0	145,0	63,0						1,8	74,5

ROCCHETTI IN MATERIALE TERMOPLASTICO

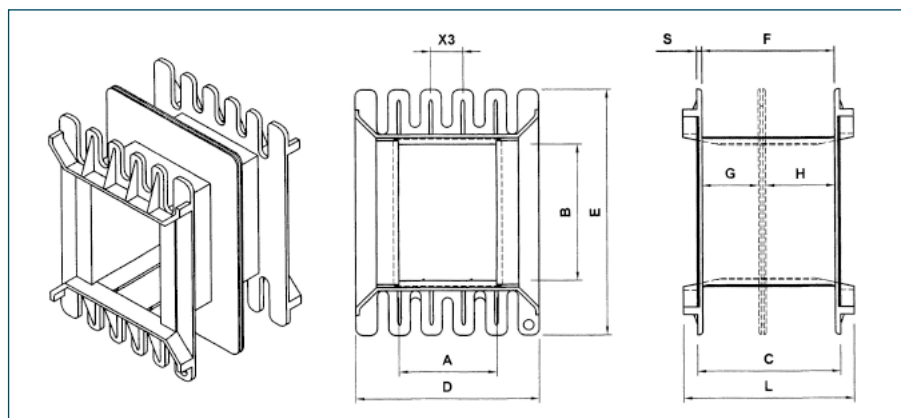

VARIANTE FLANGIA LISCIA (■)

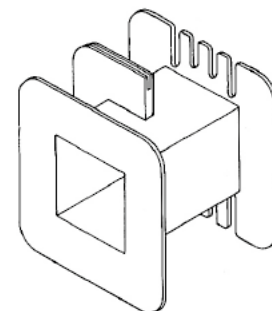

EI 150

Lam. 125X150

TYPE	REF.	a	b	c	d	e	f	g	h	x1	GG	T	s	L	z1	z4	numero term.	variante flangia liscia
EI 150/40	5040V/1-2	51,0	40,0	73,1	96,5	100	68,2	35,5	30,5				2	82				■
EI 150/50	5050G/1-2	51,0	51,0	73,1	96,5	110	68,2	35,5	30,5		■	■	2	82				■
EI 150/55	5055G/1-2	51,0	55,5	73,1	96,5	115	68,2	35,5	30,5				2	82				
EI 150/60	5060G/1-2	51,0	61,0	73,1	96,5	120	68,2	35,5	30,5		■	■	2	82				■
EI 150/70	5070G/1-2	51,0	71,0	73,1	96,5	130	68,2	35,5	30,5		■	■	2	82				■
EI 150/80	5080G/1-2	51,0	81,0	73,1	96,5	140	68,2	35,5	30,5		■	■	2	82				■
EI 150/90	5090G/1-2	51,0	91,0	73,1	96,5	150	68,2	35,5	30,5		■	■	2	82				■
EI 150/100	50100G/1-2	51,0	101,0	73,1	96,5	160	68,2	35,5	30,5		■	■	2	82				■
EI 150/110	50110G/1-2	51,0	111,0	73,1	96,5	170	68,2	35,5	30,5				2	82				■
EI 150/120	50120V/1	51,0	120,0	73,1	96,5	180	68,2						2	82				

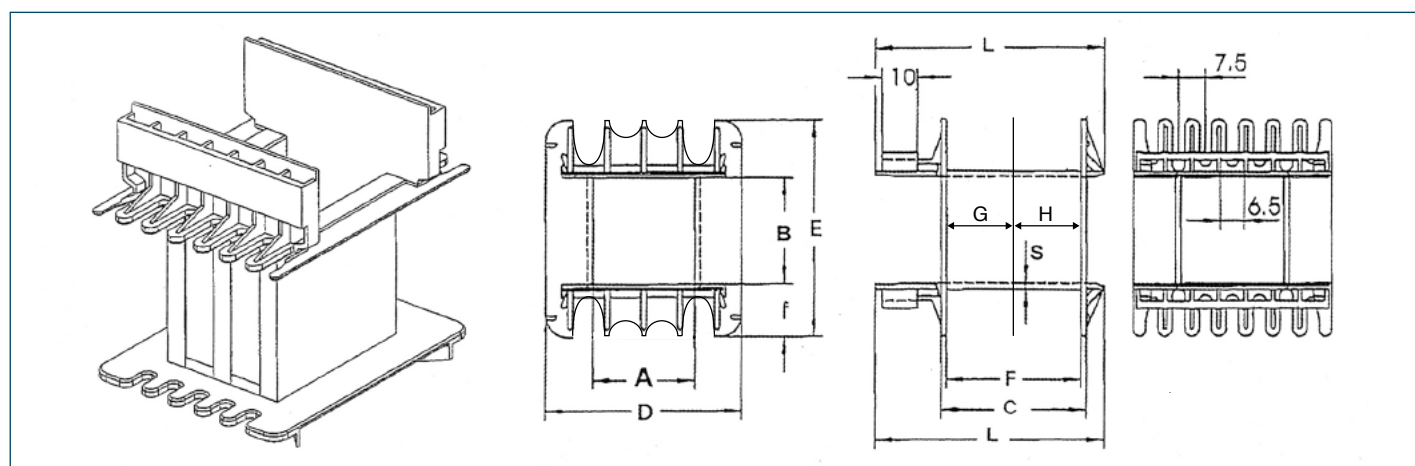

EI 150

Lam. 125X150

TYPE	REF.	a	b	c	d	e	f	g	h	s	L
EI 150/49	5049K/1	51,0	49,6	73,0	96,5	107,0	69,0			2	93
EI 150/66	5066K/1	51,0	66,6	73,0	96,5	123,5	69,0			2	93
EI 150/92	5092K/1	51,0	92,6	73,0	96,5	139,5	69,0			2	93

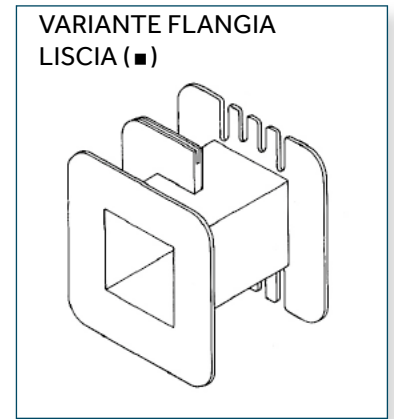
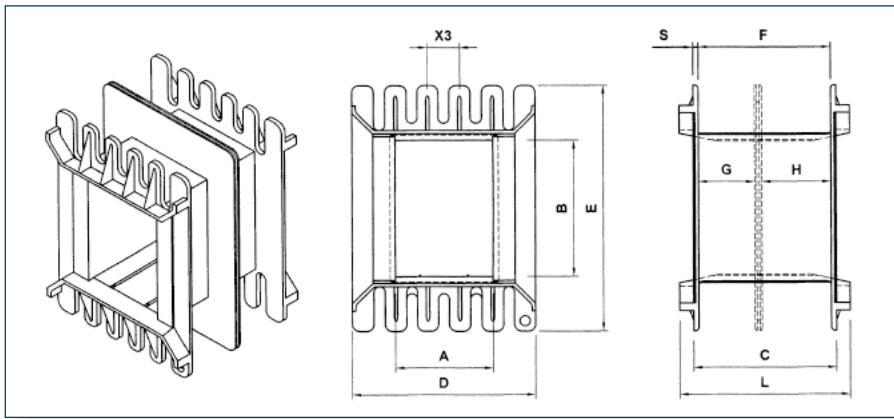

EI 180

Lam. 150X180

TYPE	REF.	a	b	c	d	e	f	g	h	s	L	variante flangia liscia
EI 180/50	6050V/1-2	61,0	50,0	88,5	118	125	83,0	42,5	38,5	2,35	98,0	■
EI 180/60	6060V/1-2	61,0	60,0	88,5	118	135	83,0	42,5	38,5	2,35	98,0	■
EI 180/70	6070V/1-2	61,0	70,0	88,5	118	145	83,0	42,5	38,5	2,35	97,0	■
EI 180/80	6080V/1-2	61,0	80,0	88,5	118	156	83,0	42,5	38,5	2,35	97,0	■
EI 180/90	6090V/1-2	61,0	90,0	88,5	118	165,5	83,0	42,5	38,5	2,35	98,0	■
EI 180/100	60100V/1-2	61,0	99,5	88,5	118	175	83,0	42,5	38,5	2,35	97,0	■
EI 180/110	60110V/1-2	61,5	110,0	88,5	118	185,5	83,0	42,5	38,5	2,35	97,0	■
EI 180/120	60120V/1-2	61,5	119,5	88,5	118	195,5	83,5	42,5	38,5	2,35	97,0	■

EI 192

Lam. 160X192

TYPE	REF.	a	b	c	d	e	f	g	h	x1	x2	x3	s	L
EI 192/60	6460V/1	65,5	60,0	94,8	125,3	134	89,7						2,3	103,0
EI 192/64	6464V/1	65,5	64,0	94,8	125,5	145	89,8	42,0	44,9				2,3	103,0
EI 192/70	6470V/1-2	65,5	70,0	94,8	125,0	146	90,0	42,0	44,9				2,2	103,0
EI 192/80	6480V/1-2	65,5	80,0	94,8	125,0	156	90,0	42,0	44,9				2,2	103,0
EI 192/90	6490V/1-2	65,5	90,0	94,8	125,0	166	90,0	42,0	44,9				2,2	103,0
EI 192/100	64100V/1-2	65,5	100,0	94,5	125,5	176	90,0	42,0	44,5				2,2	103,0
EI 192/110	64110V/1-2	65,5	110,5	94,5	125,5	186	89,7	42,0	44,5				2,2	103,0
EI 192/120	64120V/1-2	65,5	120,5	94,5	125,5	196	89,7	42,0	44,5				2,2	103,0
EI 192/130	64130V/1-2	65,5	130,0	94,5	126,0	206	89,7	42,0	44,5				2,2	103,0
EI 192/150	64150V/1-2	65,8	149,5	94,5	126,2	226	89,7	42,0	44,5				2,2	103,0

CieRe ...alles mögliche

...und noch mehr!

Haben sie besondere projekte?
Möchten sie ein angebote? Wünschen sie ein paar angebote?
Planen sie eine grosse produktion und sie möchten?
Die kosten der pressformen amortisieren?

ZIEHEN SIE UNS ZU RATE!

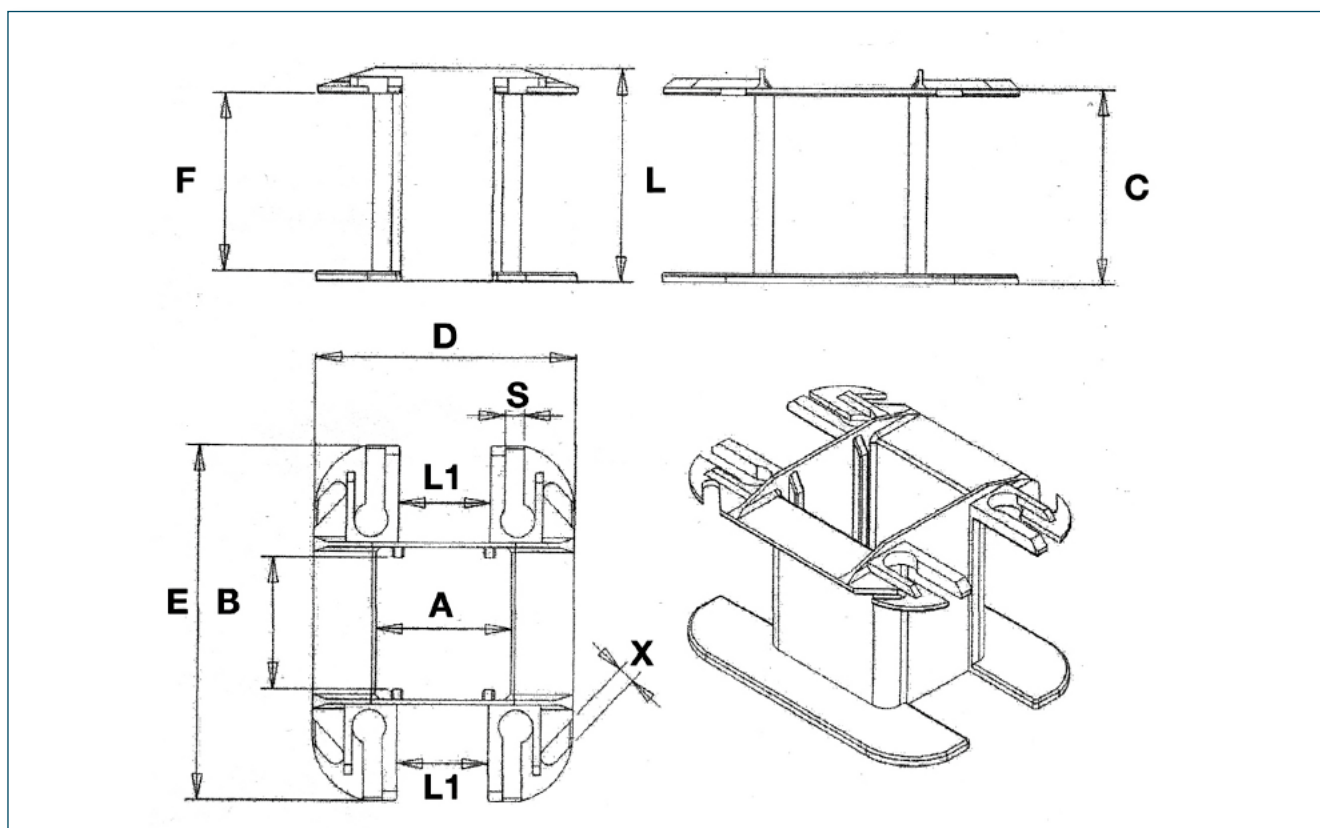

EI 210

Lam. 180X210

TYPE	REF.	a	b	d	e	c	f	l	x	L1	s
EI 210/70	7070V/1	71	70	137	187	103	92,5	113,5	9	48	10
EI 210/80	7080V/1	71	80	137	197	103	92,5	113,5	9	48	10
EI 210/90	7090V/1	71	90	137	207	103	92,5	113,5	9	48	10
EI 210/100	70100V/1	71	100	137	217	103	92,5	113,5	9	48	10
EI 210/110	70110V/1	71	110	137	227	103	92,5	113,5	9	48	10
EI 210/120	70120V/1	71	120	137	237	103	92,5	113,5	9	48	10
EI 210/130	70130V/1	71	130	137	247	103	92,5	113,5	9	48	10

IMPORTANT NEWS WE HAVE IMPERIAL DIMENSIONS MONOFASE SERIE UK/ SINGLE PHASE UK PAT TERN (UK)

TIPO / MODEL		COLONNA / COLUMN	REF.UNEL mm	PAGE OF CATALOGUE
UK CODE	OUR CODE	C		
18	UK018	14,287 (.563)	EI 42	14
147	UK147	22,226 (.875)	EI 66	15
196	UK196	28,575 (.5625)	EI 84	18-19-20
78	UK078	31,75 (1.250)	EI 96	21-22-23
120	UK120	38,1 (1.500)	EI 114	24
248	UK248	44,45 (1.750)	EI 135	27
217	UK217	88,90 (3.500)	EI 270	31

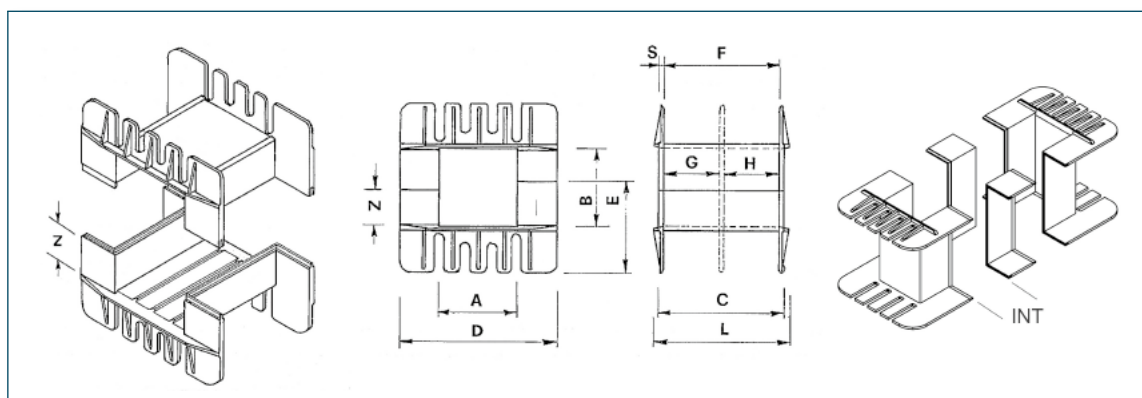

EI 240

Lam. 200X240

TYPE	REF.	A	Z	C	D	E	F	G	H	S	INT	L
EI 240/30	8030V/1-2	81,5	30	119	157	80	113	54,5	54,5	2,2		128
EI 240/40	8040V/1-2	81,4	40	119	157	87	113	54,5	54,5	2,2		128
EI 240/50	8050V/1-2	81,5	50	119	157	95	113	54,5	54,5	2,2		128
EI 240/60	8060V/1-2	81,5	60	119	157	102	113	54,5	54,5	2,2		128
EI 240/INT	INT80D/EI	INTERCALARE MISURA UNICA										50

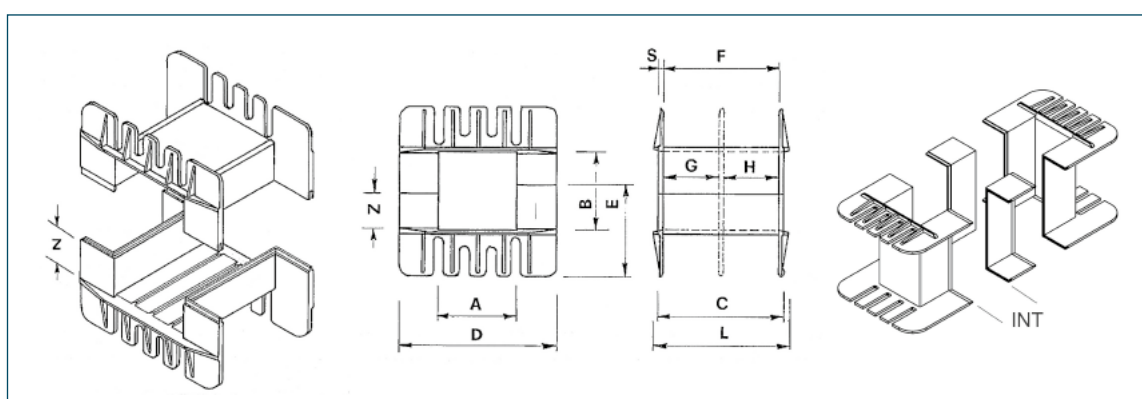

EI 270

Lam. 223X270

TYPE	REF.	A	Z	C	D	E	F	L	INT	S
EI 270/45	9045V/I	92	45	133	176	102	124,5	141		3
EI 270/55	9055V/I	92	45	133	176	112	124,5	141		3
EI 270/INT/30	INT90/30									30
EI 270/INT/40	INT90/40									40

**Non sederti ad aspettare che le opportunità arrivino.
Devi alzarti e crearle da solo.**

Quando sottovaluti ciò che fai, il mondo sottovaluterà ciò che sei.

ROCCHETTI PER NUCLEI - "C" SINGOLI - "C" CORES

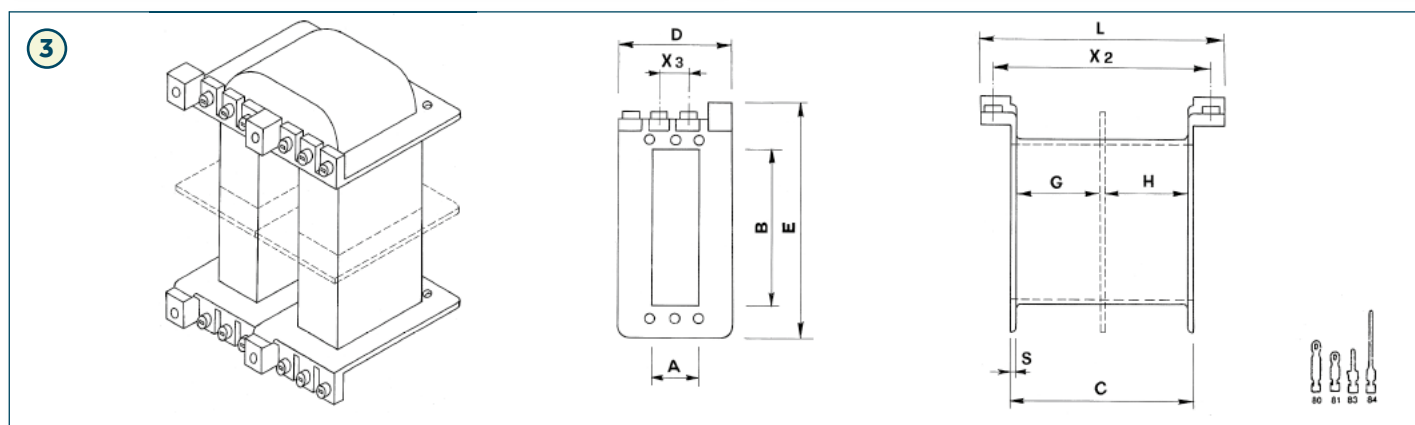
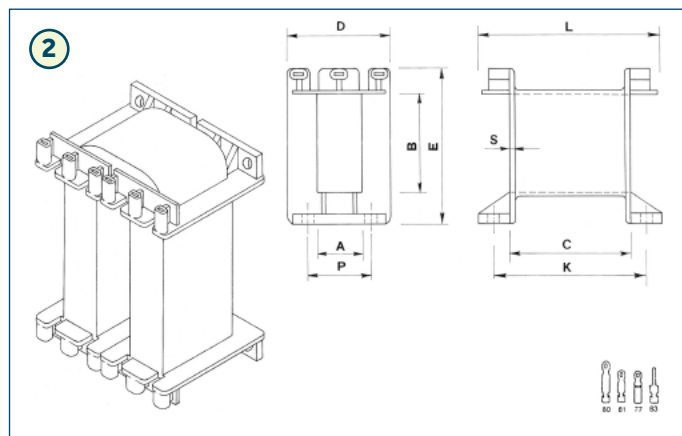
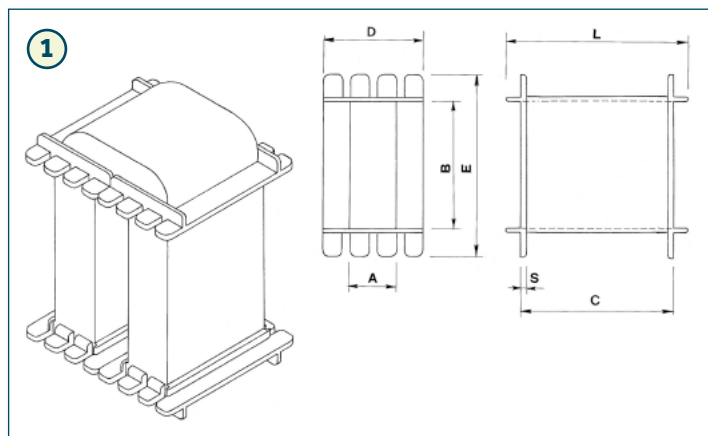

REF.HWR	REF.FA	a	b	c	d	e	P	K	G	H	x2	x3	S	L	numero term.	disegno
3/4	D6S	7,5	7,5	14,5	13,5	14,2							1,0	17,5		1
5/6	H10S	10,5	10,5	22,0	20,0	20,0							1,2	26,0		1
7/6	J10S	11,2	11,2	27,8	20,4	20,4							1,2	27,8	2X2	3
10/8	Q13S/1-2	9,5	13,5	37,6	21,5	31,7			17,5	17,5	50	7,5	1,2	53,2	2X3	3
10/12	Q19S	9,5	20,0	38,0	21,5	37,0	14,8	46,8					1,0	53,5	2X3	2
30/20	T32S	11,7	32,5	48,1	25,5	53,10							1,5	49,7		
40/16	U25S	12,0	27,0	56,5	26,5	44,0	18,0	65,0					1,5	73,0	2X3	2
40/20	U32S	12,0	33,0	57,0	27,0	54,0	18,0	65,0				6,0	1,5	73,0	2X3	2
40/24	U38S	11,5	39,7	58,0	28,5	60,5	18,0	65,0				6,0	1,5	74,0	2X3	2
50/24	V38S	15,0	39,5	61,0	35,0	62,5							1,5	69,0		1
70/18	X29S	18,2	30,7	72,2	44,2	59,1							1,7	75,0		1
70/32	X51S	18,0	53,3	71,4	43,2	80,0							1,8	75,0		1
110/20	AD32S	27,0	33,5	110,4	65,0	76,1							1,8	113,4		1
110/32	AD51S	27,5	53,0	110,0	70	95,0							2,8	113,4		1
	AP51S	42,5	53,0	176,0	101,0	112,6							1,5	180,2		1

Noi imprenditori siamo solitari, vagabondi, piantagrane.

Il successo è semplicemente una questione di trovare e circondarsi di quelle anime aperte e intelligenti che possono prendere la nostra follia e metterla a frutto.

Fai ciò che ami e il successo seguirà.

La passione è il carburante dietro una carriera di successo.

ROCCHETTI PER NUCLEI - "C" DOPPI - HWR - "C" CORES

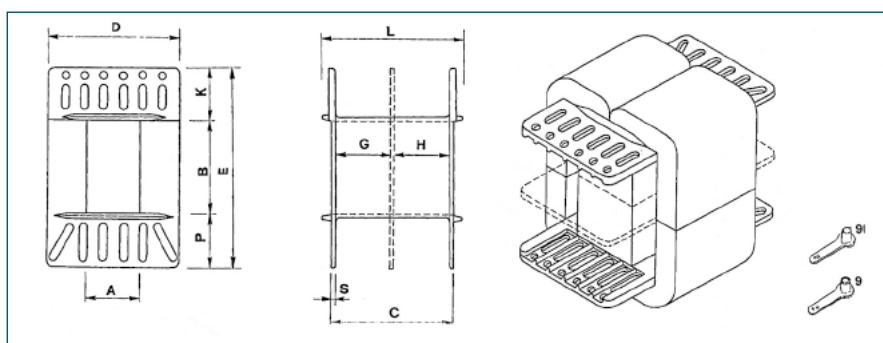

REF. HWR	REF. FA	a	b	c	d	e	f	g	h	P	K	x3	S	L
10/8	Q13D/1	19,0	14,0	36,0	43,0	48				15,0	19,0		1,5	42
10/12	Q19D/1	19,0	21,0	36,0	43,0	56				15,0	20,0		1,5	43
10/16	Q25D/1	19,0	26,5	36,0	43,0	62				15,0	20,2		1,5	42
10/24	Q38D/1	19,0	39,5	36,0	43,0	72				15,0	17,5		1,5	43
30/12	T19D/1	23,0	20,5	49,0	52,5	62				18,0	23,5		1,5	54
30/16	T25D/1	22,5	26,5	49,0	52,5	67		23,8	23,8	18,0	22,5		1,5	54
30/20	T32D/1	22,5	33,5	49,0	52,5	73				18,0	21,5		1,5	54
40/20	U32D/1	22,5	33,5	54,0	57,5	79				21,0	25,0		1,5	59
40/24	U38D/1	23,0	40,0	54,0	57,5	85				21,0	24,5		1,5	59
50/18	V29D/1	29,0	31,0	60,0	72,0	84				25,0	28,0		2,0	65
50/24	V38D/1	29,0	39,0	60,0	72,0	93				25,0	29,0		2,0	65
50/32	V51D/1	29,0	53,0	60,0	72,0	107				25,0	29,0		2,0	65
70/18	X29D/1	35,0	31,0	72,0	90,0	92				36,0	36,0		2,3	79
70/24	X38D/1	35,0	40,0	72,0	90,0	112				36,0	36,0		2,3	79
70/32	X51D/1	35,0	53,0	72,0	90,0	122				33,5	35,5		2,5	80
90/44	Z70D/1	42,0	72,0	86,0	107,0	155				41,5	41,5		2,5	98

TELAI NUCLEI "C" E ACCESSORI

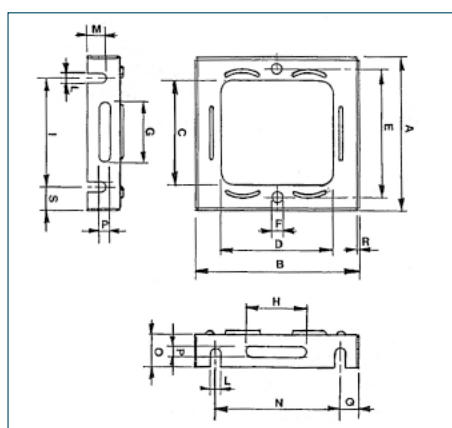

Guarnizione
isolanti per telai
Q - T - U
V - X - Z

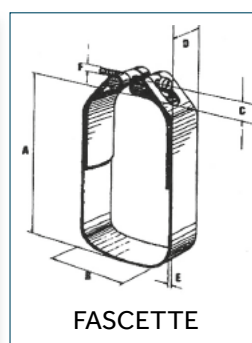

TYPE	A	B	C	D	E	F
FA - AD	170	98	7	10	0,5	Ø 4
FA - Q	62	32	7	10	0,4	Ø 3
FA - T	76	39	7	10	0,4	Ø 3
FA - U	84	42	7	10	0,4	Ø 3
FA - V	94	52	7	10	0,4	Ø 3
FA - X	114	65	7	10	0,5	Ø 4
FA - Z	134	76	7	10	0,5	Ø 4

TYPE	REF.	A	B	C	D	E	F	G	H	I	L	M	N	O	P	Q	R	S
AD	TELAIO AD-FE	170	210	120	145	130	8,5	80	100	125	8,5	12	145	25	5,2	15	2	15
Q	TELAIO Q-FE	62	66	45,5	49	52	4,2	25	25	44	4,2	7	52	13	3,2	17,2	1,2	19
T	TELAIO T-FE	79	81	56	58,5	66,5	5,2	35	35	60	5,2	9	66	15	4,2	7,5	1,2	9,5
U	TELAIO U-FE	87	87	63,5	65,5	76	5,2	40	40	70	5,2	9	70	15	4,2	8,5	1,2	8,5
V	TELAIO V-FE	98	106	73	78,5	83	5,6	45	45	75	6,2	9	85	17	4	10,5	1,2	11,5
X	TELAIO X-FE	120	134	86	98,5	103,5	7,2	55	65	96	7,2	12	110	19	4,2	12	1,5	12
Z	TELAIO Z-FE	140	158	99	117,5	119,5	8,2	80	100	114	8,5	12	132	25	5,2	13	1,5	13

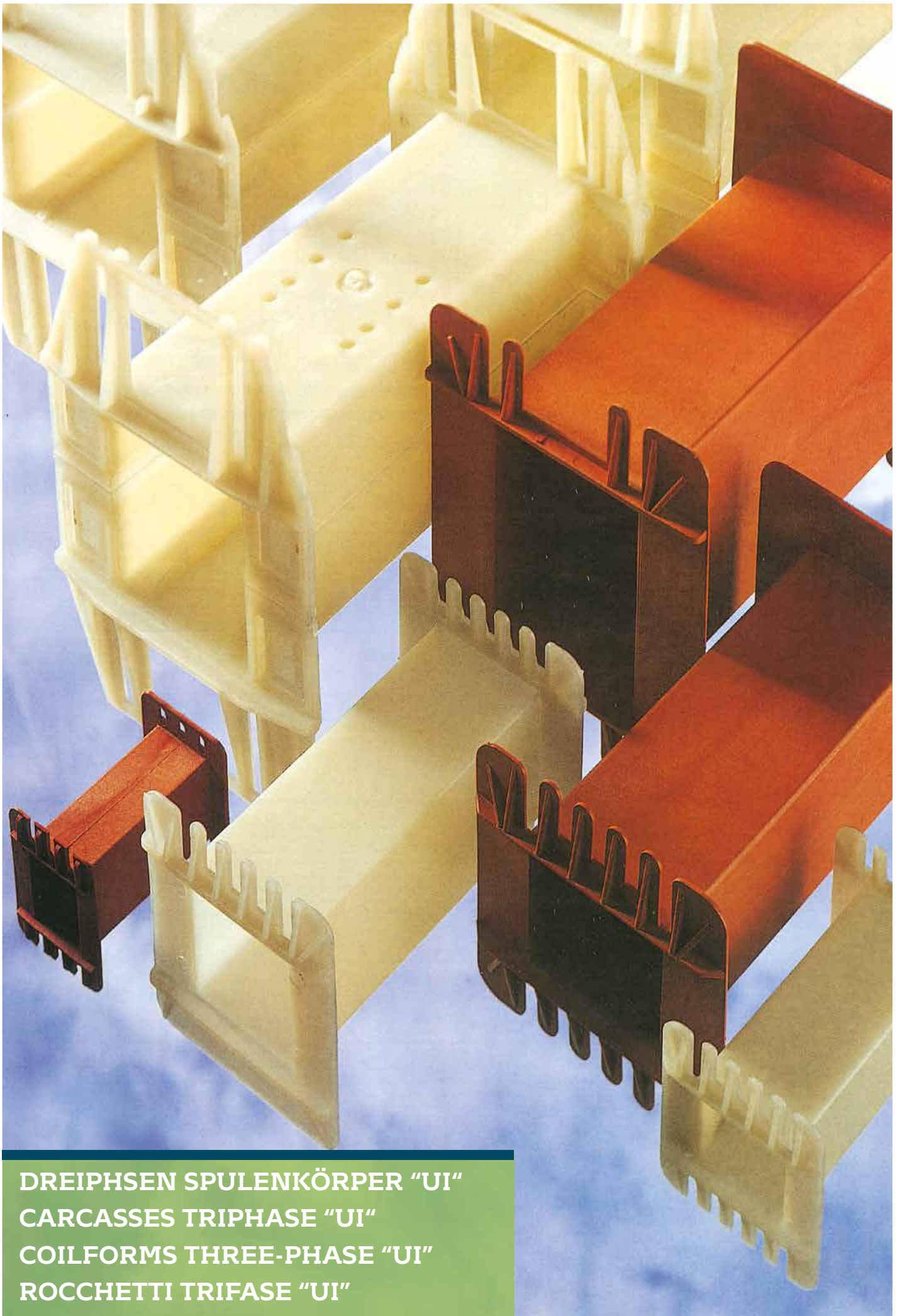

DREIPHASEN SPULENKÖRPER "UI"
CARCASSES TRIPHASE "UI"
COILFORMS THREE-PHASE "UI"
ROCCHETTI TRIFASE "UI"

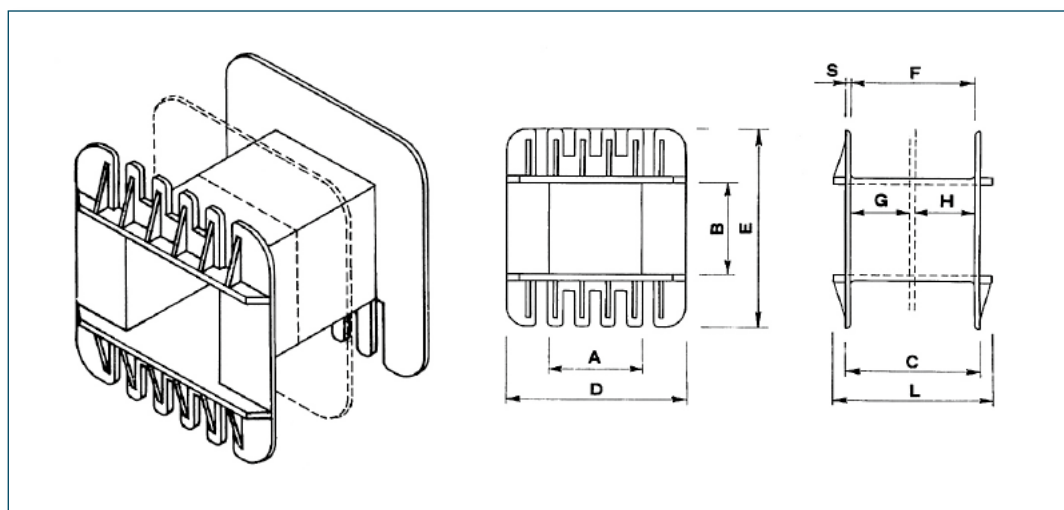

UI 60

Lam. 100X100

TYPE	REF.	a	b	c	d	e	f	g	h	x1	x2	x3	s	l
UI 60/21	202160/1-2	20,8	21,0	59,0	39,0	44,0	56,6	27,5	27,5				1,2	63,5
UI 60/30	203060/1-2	20,8	30,0	59,0	39,0	53,0	56,6	27,5	27,5				1,2	63,5
UI 60/40	204060/1	20,8	40,0	59,0	39,0	63,0	56,6						1,2	63,5
UI 60/50	205060/1	20,8	50,0	59,0	39,0	73,0	56,6						1,2	63,5

UI 66

Lam. 112X132

TYPE	REF.	a	b	c	d	e	f	g	h	x1	x2	x3	s	l
UI 66/30	233066/1	23,8	30,0	65,7	52,0	63,0	62,5						1,6	69,6
UI 66/40	234066/1	23,8	40,0	65,7	52,0	68,0	62,5						1,6	69,6
UI 66/45	234566/1	23,8	45,0	65,7	52,0	78,0	62,5						1,6	69,6
UI 66/50	235066/1	23,8	50,0	65,7	52,0	88,0	62,5						1,6	69,6

UI 68

Lam. 110X120

TYPE	REF.	a	b	c	d	e	f	g	h	x1	x2	x3	s	l
UI 68/40	234068/1	23,8	40,0	66,2	42,0	66,2	62,5						1,8	72,2

UI 75

Lam. 125X125

TYPE	REF.	a	b	c	d	e	f	g	h	x1	x2	x3	s	l
UI 75/25	252575/1	26,0	26,0	74,5	49,5	58,0	71,5						1,5	82,5
UI 75/30	253075/1	26,0	31,0	74,5	49,5	63,0	71,5						1,5	82,5
UI 75/40	254075/1	26,0	41,0	74,5	49,5	73,0	71,5						1,5	82,5

ROCCHETTI TRIFASE IN MATERIALE TERMOPLASTICO "UI"

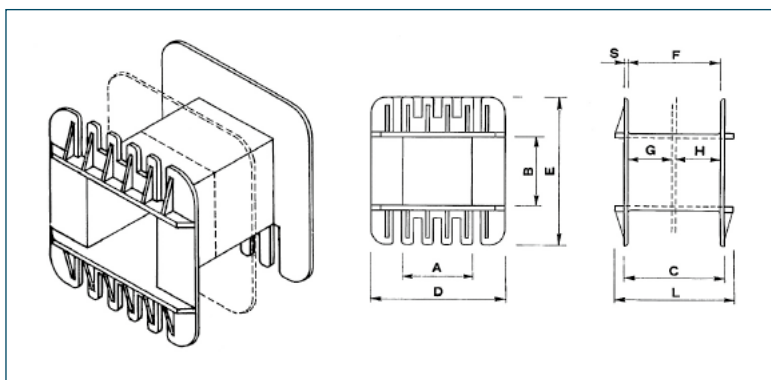

UI 90

Lam. 150X150

TYPE	REF.	a	b	c	d	e	f	g	h	x1	x2	x3	s	l
UI 90/30	303090/1-2	31,0	30,0	88,5	59,0	69,0	85,5	42,0	42,0				1,5	93,0
UI 90/35	303590/1-2	31,0	35,0	88,5	59,0	74,0	85,5	42,0	42,0				1,5	93,0
UI 90/40	304090/1-2	31,0	40,0	88,5	59,0	79,0	85,5	42,0	42,0				1,5	93,0
UI 90/45	304590/1-2	31,0	45,0	88,5	59,0	84,0	85,5	42,0	42,0				1,5	93,0
UI 90/50	305090/1-2	31,0	50,0	88,5	59,0	89,0	85,5	42,0	42,0				1,5	93,0
UI 90/55	305590/1-2	31,0	55,0	88,5	59,0	95,0	85,5	42,0	42,0				1,5	93,0
UI 90/60	306090/1-2	31,0	60,0	88,5	59,0	99,0	85,5	42,0	42,0				1,5	93,0
UI 90/75	307590/1-2	31,0	76,0	88,5	59,0	116,0	85,5	42,0	42,0				1,5	93,0

UI 100

Lam. 200X180

TYPE	REF.	a	b	c	d	e	f	g	h	x1	x2	x3	s	l
UI 100/40	4040100/1	41,0	40,0	98,5	73,0	85,0	94,5						1,8	104,0
UI 100/50	4050100/1	41,0	50,0	98,5	73,0	95,0	94,5						1,8	104,0
UI 100/60	4060100/1	41,0	60,0	98,5	73,0	105,0	94,5						1,8	104,0
UI 100/70	4070100/1	41,0	70,0	98,5	73,0	115,0	94,5						1,8	104,0
UI 100/100	40100100/1	41,0	100,0	98,5	73,0	145,0	94,5						1,8	104,0

UI 120

Lam. 200X200

TYPE	REF.	a	b	c	d	e	f	g	h	CON FLANGIA INTERMEDIA SPOSTATA	s	l
UI 120/40	4040120/1-2	41,0	40,0	119,0	78,0	85,0	115,4	58,0	55,5		1,8	127,8
UI 120/40	4040120/62	41,0	40,0	119,0	78,0	85,0	115,4	62,5	51,0	■	1,8	127,8
UI 120/40	4040120/69	41,0	40,0	119,0	78,0	85,0	115,4	69,5	44,0	■	1,8	127,8
UI 120/50	4050120/1-2	41,0	50,0	119,0	78,0	95,0	115,4	56,0	54,0		1,8	127,8
UI 120/60	4060120/1-2	41,0	60,0	119,0	78,0	105,0	115,4	58,0	55,5		1,8	127,8
UI 120/60	4060120/60	41,0	60,0	119,0	78,0	105,0	115,4	60,0	53,5	■	1,8	127,8
UI 120/60	4060120/72	41,0	60,0	119,0	78,0	105,0	115,4	72,0	38,5	■	1,8	127,8
UI 120/75	4075120/1-2	41,0	75,0	119,0	78,0	120,0	115,4	58,0	55,5		1,8	127,8
UI 120/80	4080120/1	41,0	80,0	119,0	78,0	125,0	115,4				2,0	127,8
UI 120/80	4080120/72	41,0	80,0	119,0	78,0	125,0	115,4	72,0	38,5		2,0	127,8

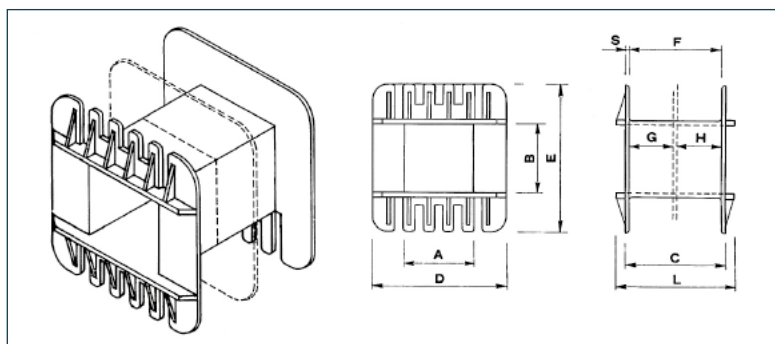

UI 150

Lam. 250X250

TYPE	REF.	a	b	c	d	e	f	g	h	CON FLANGIA INTERMEDIA SPOSTATA	s	L
UI 150/40	5040150/1	51,2	40,0	149,4	98,0	98,0	145,3				2,0	156,0
UI 150/50	5050150/1-2	51,2	50,0	149,4	98,0	108,0	145,3	70,7	70,7		2,0	156,0
UI 150/50	5050150/95	51,2	50,0	149,4	98,0	108,0	145,3	95,6	46,0	■	2,0	156,0
UI 150/60	5060150/1-2	51,2	60,0	149,4	98,0	118,0	145,3	76,0	65,3		2,0	156,0
UI 150/60	5060150/95	51,2	60,0	149,4	98,0	118,0	145,3	95,6	46,0	■	2,0	156,0
UI 150/65	5065150/1-2	51,2	65,0	149,4	98,0	123,3	145,3	76,0	65,3		2,0	156,0
UI 150/70	5070150/1-2	51,2	70,0	149,4	98,0	128,0	145,3	76,0	65,3		2,0	156,0
UI 150/70	5070150/95	51,2	70,0	149,4	98,0	128,0	145,3	95,6	46,0	■	2,0	156,0
UI 150/80	5080150/1-2	51,2	80,0	149,4	98,0	138,0	145,3	81,6	60,0		2,0	156,0
UI 150/80	5080150/95	51,2	80,0	149,4	98,0	138,0	145,3	95,6	46,0	■	2,0	156,0
UI 150/90	5090150/1-2	51,2	90,0	149,4	98,0	147,6	145,3	76,0	68,2		2,0	156,0
UI 150/90	5090150/81	51,2	90,0	149,4	98,0	147,6	145,3	81,6	60,0	■	2,0	156,0
UI 150/100	50100150/1V	51,2	100,0	149,4	98,0	157,2	145,3				2,0	156,0
UI 150/100	50100150/1	51,2	100,0	149,4	98,0	157,2	145,3				2,0	164,0

UI 180/C Ridotto

Lam. 270X300

TYPE	REF.	a	b	c	d	e	f	g	h	x1	x2	x3	s	L
UI 180C/60	6060150/91	61,5	60,0	148,0	118,0	126	142,5	91	49,3				2,2	124
UI 180C/70	6070150/1-2	61,5	70,0	148,0	118,0	136	142,5	91	49,3				2,2	124
UI 180C/80	6080150/1-2	61,5	80,0	148,0	118,0	146	142,5	91	49,3				2,2	124
UI 180C/105	60105150/91	61,5	105,0	148,0	118,0	171	142,5	91	49,3				2,2	124

UI 180

Lam. 300X300

TYPE	REF.	a	b	c	d	e	f	g	h	x1	x2	x3	s	L
UI 180/60	6060180/1-2	61,0	60,0	179,0	118,0	135,0	173,0	86,0	84,5				2,5	186,0
UI 180/70	6070180/1-2	61,0	70,0	179,0	118,0	145,0	173,0	86,0	84,5				2,5	186,0
UI 180/80	6080180/1-2	61,0	80,0	179,0	118,0	155,0	173,0	86,0	84,5				2,5	186,0
UI 180/90	6090180/1-2	61,0	90,0	179,0	118,0	165,0	173,0	86,0	84,5				2,5	186,0
UI 180/100	60100180/1	61,5	100,0	179,0	118,0	175,0	173,0	86,0	84,5				2,5	186,0

ROCCHETTI TRIFASE IN MATERIALE TERMOPLASTICO "UI"

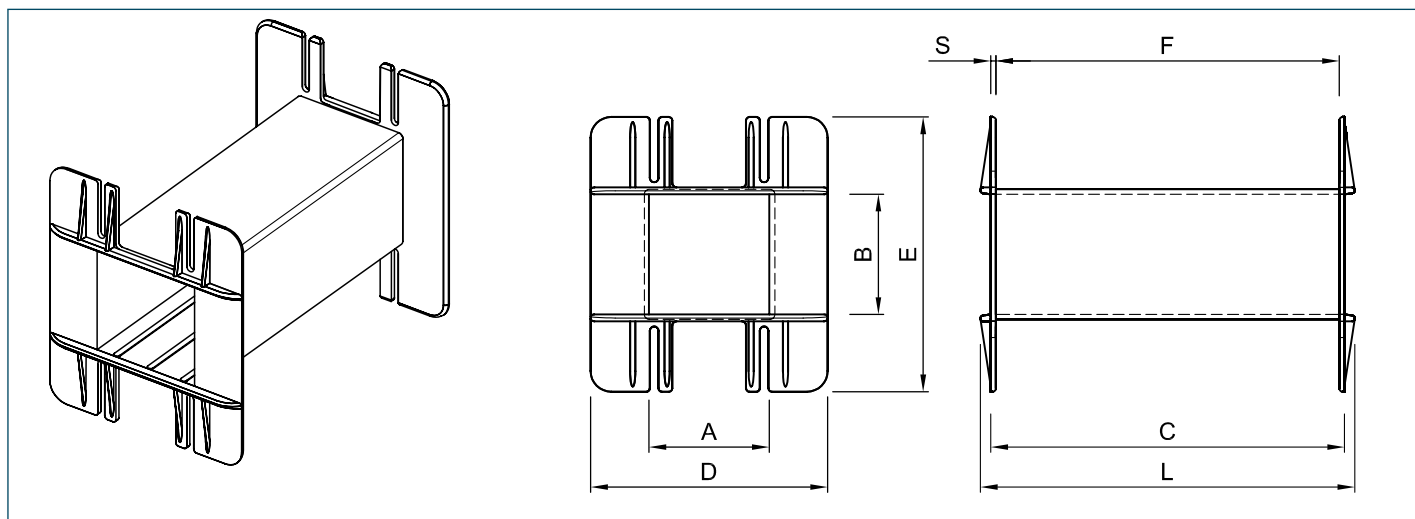

UI 210

Lam. 350X350

TYPE	REF.	a	b	c	d	e	f	s	l
UI 210/70	7070210/1U	72,00	71,50	209,00	138,50	162,00	203,50	3,00	223,50
UI 210/80	7080210/1U	72,00	81,50	209,00	138,50	172,00	203,50	3,00	223,50
UI 210/90	7090210/1U	72,00	90,80	209,00	138,50	192,00	203,50	3,00	222,00
UI 210/100	70100210/1U	72,00	100,80	209,00	138,50	192,00	203,50	3,00	222,00

ROCCHETTI TRIFASE CON DISSIPAZIONE CALORE "UI" MOD. TUB AIR COOLING SYSTEM - LUFTKÜHLSYSTEM

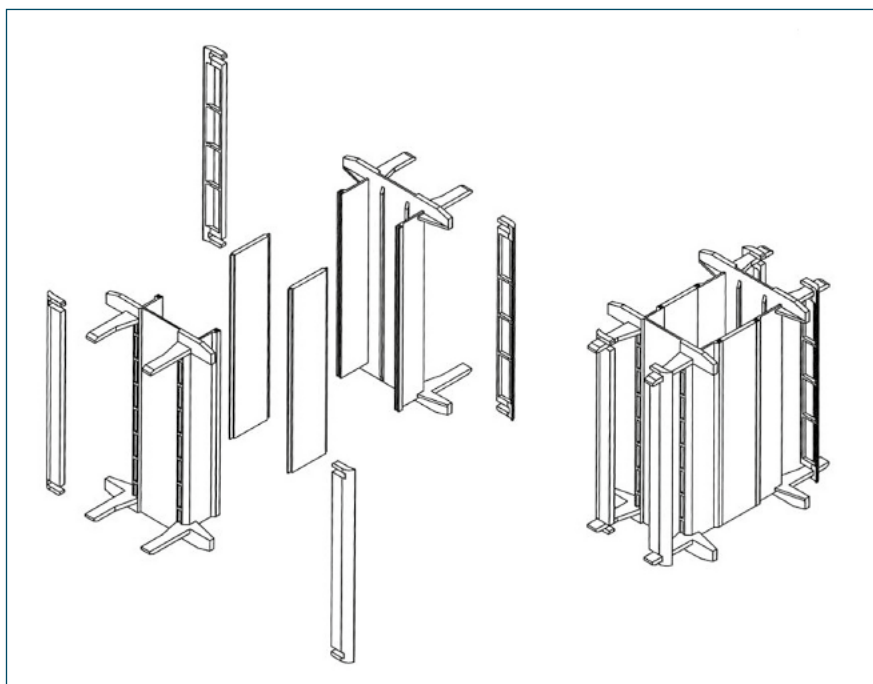

Cerca di non diventare un uomo di successo.
Piuttosto diventa un uomo di valore.

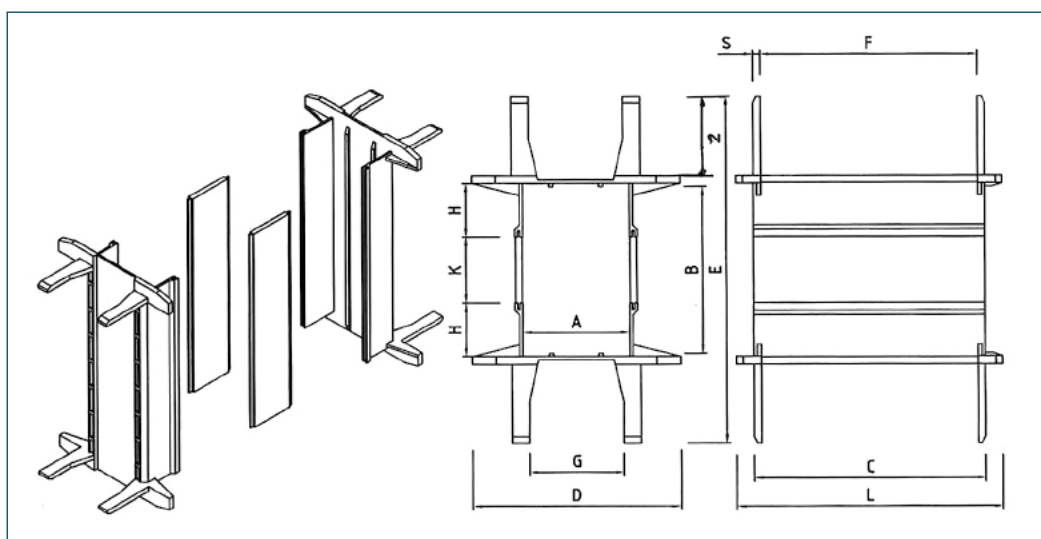

UI 180

Lam. 300X300

TYPE	DESCRIZIONE	REF.	A	B	C	D	E	F	G	H	K _{int}	L	S	Z
UI 180	SEMIROCCHETTO	60180R/TUB	61,0		179	118		167	50	30		196	2,5	40
UI 180/60	INTERCALARE 60X80/T	INT 6080/T	61,0	60	179	118	140	167			1	196	2,5	
UI 180/70	INTERCALARE 60 X90/T	INT 6090/T	61,0	70	179	118	150	167			10	196	2,5	
UI 180/80	INTERCALARE 60X100/T	INT 60100/T	61,0	80	179	118	160	167			20	196	2,5	
UI 180/90	INTERCALARE 60X110/T	INT 60110/T	61,0	90	179	118	170	167			30	196	2,5	
UI 180/100	INTERCALARE 60X120/T	INT 60120/T	61,0	100	179	118	180	167			40	196	2,5	
UI 180/110	INTERCALARE 60X130/T	INT 60130/T	61,0	110	179	118	190	167			50	196	2,5	
UI 180/120	INTERCALARE 60X140/T	INT 60140/T	61,0	120	179	118	200	167			60	196	2,5	
UI 180/130	INTERCALARE 60X150/T	INT 60150/T	61,0	130	179	118	210	167			70	196	2,5	

UI 210

Lam. 350X350

TYPE	DESCRIZIONE	REF.	A	B	C	D	E	F	G	H	K _{int}	L	S	Z
UI 210	SEMIROCCHETTO	70210R/TUB	71,0		209	138		197	61	35		235	2,5	60
UI 210/70	INTERCALARE 70X80/T	INT 7080/T	71,0	70	209	138	190	197			1	235	2,5	
UI 210/80	INTERCALARE 70X90/T	INT 7090/T	71,0	80	209	138	200	197			10	235	2,5	
UI 210/90	INTERCALARE 70X100/T	INT 70100/T	71,0	90	209	138	210	197			20	235	2,5	
UI 210/100	INTERCALARE 70X110/T	INT 70110/T	71,0	100	209	138	220	197			30	235	2,5	
UI 210/110	INTERCALARE 70X120/T	INT 70120/T	71,0	110	209	138	230	197			40	235	2,5	
UI 210/120	INTERCALARE 70X130/T	INT 70130/T	71,0	120	209	138	240	197			50	235	2,5	
UI 210/130	INTERCALARE 70X140/T	INT 70140/T	71,0	130	209	138	250	197			60	235	2,5	
UI 210/140	INTERCALARE 70X150/T	INT 70150/T	71,0	140	209	138	260	197			70	235	2,5	

Il modo per iniziare è quello di smettere di parlare e iniziare a fare.

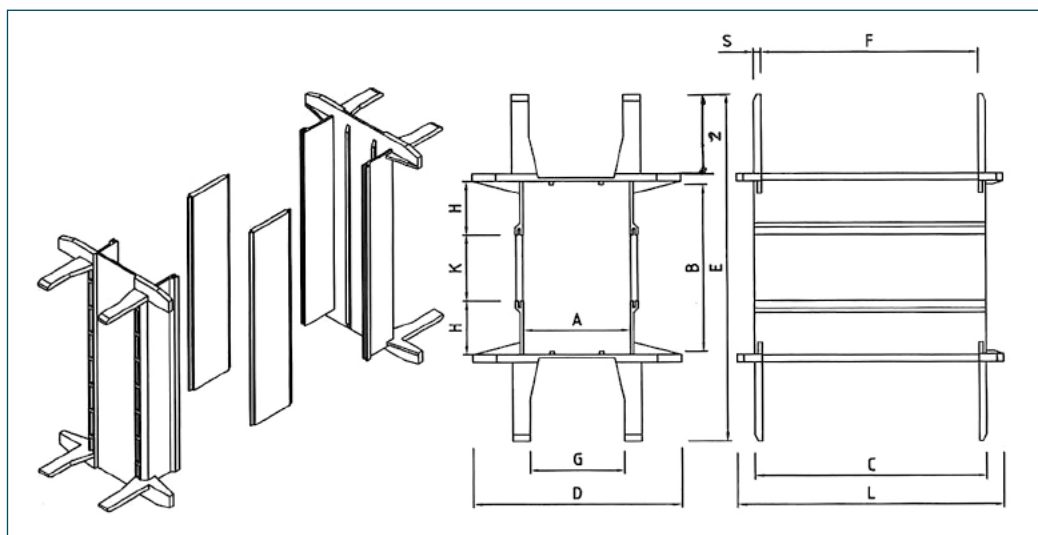

UI 240

Lam. 400X400

YPE	DESCRIZIONE	REF.	A	B	C	D	E	F	G	H	K	L	S	Z
UI 240	SEMIROCCHETTO	80240R/TUB	80,8		239	159		227	72	40		266	2,5	60
UI 240/80	INTERCALARE 80X80/T	INT 8080/T	80,8	80	239	159	200	227			1	266	3,0	
UI 240/90	INTERCALARE 80X90/T	INT 8090/T	80,8	90	239	159	210	227			10	266	3,0	
UI 240/100	INTERCALARE 80X100/T	INT 80100/T	80,8	100	239	159	220	227			20	266	3,0	
UI 240/110	INTERCALARE 80X110/T	INT 80110/T	80,8	110	239	159	230	227			30	266	3,0	
UI 240/120	INTERCALARE 80X120/T	INT 80120/T	80,8	120	239	159	240	227			40	266	3,0	
UI 240/130	INTERCALARE 80X130/T	INT 80130/T	80,8	130	239	159	250	227			50	266	3,0	
UI 240/140	INTERCALARE 80X140/T	INT 80140/T	80,8	140	239	159	260	227			60	266	3,0	
UI 240/150	INTERCALARE 80X150/T	INT 80150/T	80,8	150	239	159	270	227			70	266	3,0	

UI 300

Lam. 500X500

TYPE	DESCRIZIONE	REF.	A	B	C	D	E	F	G	H	K	L	S	Z
UI 300	SEMIROCCHETTO	100300R/TUB	101,2		299,2	199		288	88	40		327	2,5	80
UI 300/80	INTERCALARE 100X80/T	INT 10080/T	101,2	80	299,2	199	240	288			1	327	3,0	
UI 300/90	INTERCALARE 100X90/T	INT 10090/T	101,2	90	299,2	199	250	288			10	327	3,0	
UI 300/100	INTERCALARE 100X100/T	INT 100100/T	101,2	100	299,2	199	260	288			20	327	3,0	
UI 300/110	INTERCALARE 100X110/T	INT 100110/T	101,2	110	299,2	199	270	288			30	327	3,0	
UI 300/120	INTERCALARE 100X120/T	INT 100120/T	101,2	120	299,2	199	280	288			40	327	3,0	
UI 300/130	INTERCALARE 100X130/T	INT 100130/T	101,2	130	299,2	199	290	288			50	327	3,0	
UI 300/140	INTERCALARE 100X140/T	INT 100140/T	101,2	140	299,2	199	300	288			60	327	3,0	
UI 300/150	INTERCALARE 100X150/T	INT 100150/T	101,2	150	299,2	199	310	288			70	327	3,0	
UI 300/160	INTERCALARE 100X160/T	INT 100160/T	101,2	160	299,2	199	320	288			80	327	3,0	

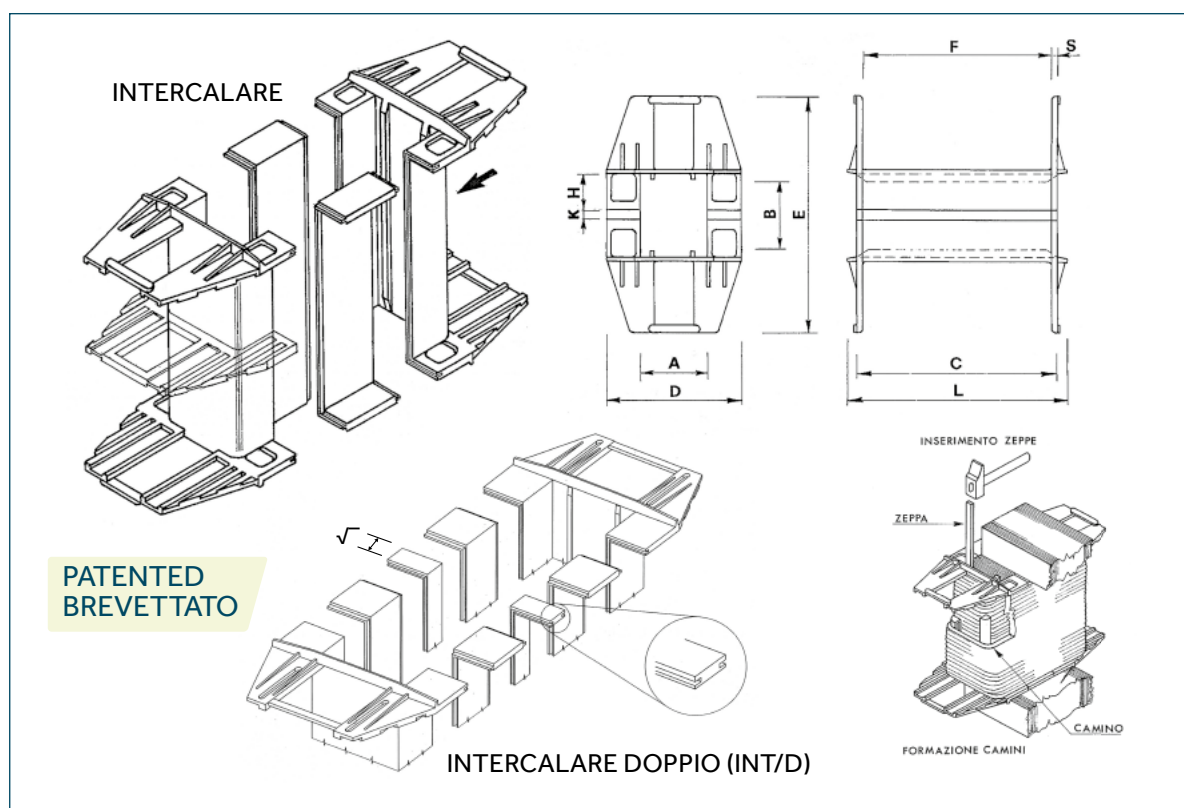

UI 150

Lam. 250X250

TYPE	DESCRIZIONE	REF.		A	B	C	D	E	F	H	S	L	Z	K
UI 150	SEMIROCCHETTO	50150R		51,5	148	98		139	37,0	4,0	162	45		
UI 150/70	SEMIROCCHETTO	5070150R		51,5	70	148	98	180	139	37,0	4,0	162	Pezzo unico senza intercalare	
UI 150/76	INTERCALARE 50X76	INT5076	misure totali semirocchetto + intercalare assemblato	51,5	76	148	98	186	139		4,0	162		10
UI 150/96	INTERCALARE 50X96	INT5096		51,5	96	148	98	206	139		4,0	162		30
UI 150/106	INTERCALARE 50X106	INT50106		51,5	106	148	98	216	139		4,0	162		40
UI 150/116	INTERCALARE 50X116	INT50116		51,5	116	148	98	226	139		4,0	162		50
UI 150/126	INTERCALARE 50x126	INT50126		51,5	126	148	98	236	139		4,0	162		60

UI 180

Lam. 300X300

TYPE	DESCRIZIONE	REF.		A	B	C	D	E	F	H	S	L	Z	K
UI 180	SEMIROCCHETTO	60180R		61,5	178,5	118,0		170,5	40,0	4,0	194,0	54,8		
UI 180/70	SEMIROCCHETTO	6070180R		61,5	70	178,5	118,0	198,0	170,5		4,0	194,0	Pezzo unico senza intercalare	
UI 180/80	INTERCALARE 60X80	INT6080	misure totali semirocchetto + intercalare assemblato	61,5	80	178,5	118,0	208,8	170,5		4,0	194,0		10
UI 180/90	INTERCALARE 60X90	INT6090		61,5	90	178,5	118,0	218,0	170,5		4,0	194,0		20
UI 180/100	INTERCALARE 60X100	INT60100		61,5	100	178,5	118,0	228,0	170,5		4,0	194,0		30
UI 180/110	INTERCALARE 60X110	INT60110		61,5	110	178,5	118,0	238,0	170,5		4,0	194,0		40
UI 180/120	INTERCALARE 60X120	INT60120		61,5	120	178,5	118,0	248,0	170,5		4,0	194,0		50
UI 180/130	INTERCALARE 60X130	INT60130		61,5	130	178,5	118,0	258,0	170,5		4,0	194,0		60
UI 180/140	INTERCALARE 60X140	INT60140		61,5	140	178,5	118,0	268,0	170,5		4,0	194,0		70
UI 180	FLANGIA INTERMEDIA FL60/UI										5,8			

ROCCHETTI TRIFASE IN MATERIALE TERMOPLASTICO "UI"

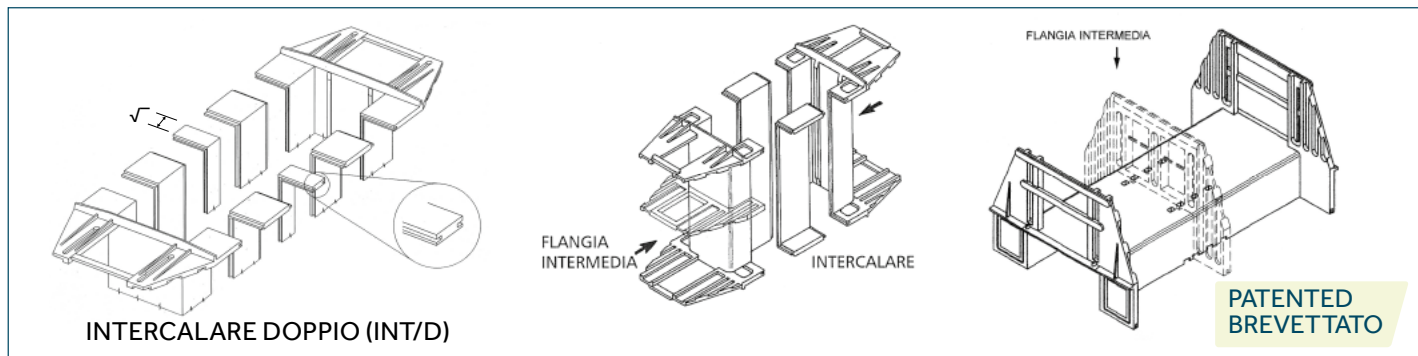

UI 210

Lam. 350X350

TYPE	DESCRIZIONE	REF.		A	B	C	D	E	F	H	S	L	Z	√	K
UI 210	SEMIROCCHETTO	70210R		72,2		209	139,5		199,8	40	4,0	229	68,6		
UI 210/72	INTERCALARE 70X72	INT7072		72,2	72	209	139,5	231	199,8		4,0	229			4
UI 210/80	INTERCALARE 70X80	INT7080	misure totali semirocchetto	72,2	80	209	139,5	237	199,8		4,0	229			10
UI 210/90	INTERCALARE 70X90	INT7090			72,2	90	209	139,5	247	199,8		4,0	229		
UI 210/102	INTERCALARE 70X102	INT70102	+ intercalare assemblato	72,2	102	209	139,5	259	199,8		4,0	229			35
UI 210/110	INTERCALARE 70X110	INT70110			72,2	110	209	139,5	267	199,8		4,0	229		
UI 210/120	INTERCALARE 70X120	INT70120		72,2	120	209	139,5	277	199,8		4,0	229			51
UI 210/132	INTERCALARE 70X132	INT70132		72,2	132	209	139,5	289	199,8		4,0	229			63
UI 210/140	INTERCALARE 70X140	INT70140		72,2	140	209	139,5	297	199,8		4,0	229			69
UI 210/....	INTERCALARE DOPPIO	INT70D	consente di aumentare a piacere il pacco lamellare									4,0			20,0
UI 210	FLANGIA INTERMEDIA	FL70/UI									5,8				

UI 240

Lam. 400X400

TYPE	DESCRIZIONE	REF.		A	B	C	D	E	F	H	S	L	Z	√	K
UI 240	SEMIROCCHETTO	80240R		81,7		239	159		229	40,1	4,0	259	74,0		
UI 240/82	INTERCALARE 80X82	INT8082		81,7	82	239	159	240	229		4,0	259			12
UI 240/90	INTERCALARE 80X90	INT8090	misure totali semirocchetto	81,7	90	239	159	248	229		4,0	259			20
UI 240/100	INTERCALARE 80X100	INT80100			81,7	100	239	159	258	229		4,0	259		
UI 240/110	INTERCALARE 80X110	INT80110	+ intercalare assemblato	81,7	110	239	159	268	229		4,0	259			40
UI 240/120	INTERCALARE 80X120	INT80120			81,7	120	239	159	278	229		4,0	259		
UI 240/130	INTERCALARE 80X130	INT80130		81,7	130	239	159	288	229		4,0	259			60
UI 240/140	INTERCALARE 80X140	INT80140		81,7	140	239	159	298	229		4,0	259			70
UI 240/150	INTERCALARE 80X150	INT80150		81,7	150	239	159	308	229		4,0	259			80
UI 240/....	INTERCALARE DOPPIO	INT80D	consente di aumentare a piacere il pacco lamellare									4,0			20,0
UI 240	FLANGIA INTERMEDIA	FL80/UI									5,8				

UI 300

Lam. 500X500

TYPE	DESCRIZIONE	REF.		A	B	C	D	E	F	H	S	L	Z	√	K
UI 300	SEMIROCCHETTO	100300R		102		298	199		291	45,3	4,0	318	83,9		
UI 300/100	INTERCALARE 100X100	INT100100		102	100	298	199	268	291		4,0	318			20
UI 300/110	INTERCALARE 100X110	INT100110	misure totali semirocchetto	102	110	298	199	278	291		4,0	318			30
UI 300/120	INTERCALARE 100X120	INT100120			102	120	298	199	288	291		4,0	318		
UI 300/130	INTERCALARE 100X130	INT100130	+ intercalare assemblato	102	130	298	199	298	291		4,0	318			50
UI 300/140	INTERCALARE 100X140	INT100140			102	140	298	199	308	291		4,0	318		
UI 300/150	INTERCALARE 100X150	INT100150		102	150	298	199	318	291		4,0	318			70
UI 300/160	INTERCALARE 100X160	INT100160		102	160	298	199	328	291		4,0	318			80
UI 300/....	INTERCALARE DOPPIO	INT100D	consente di aumentare a piacere il pacco lamellare									4,0			20,0

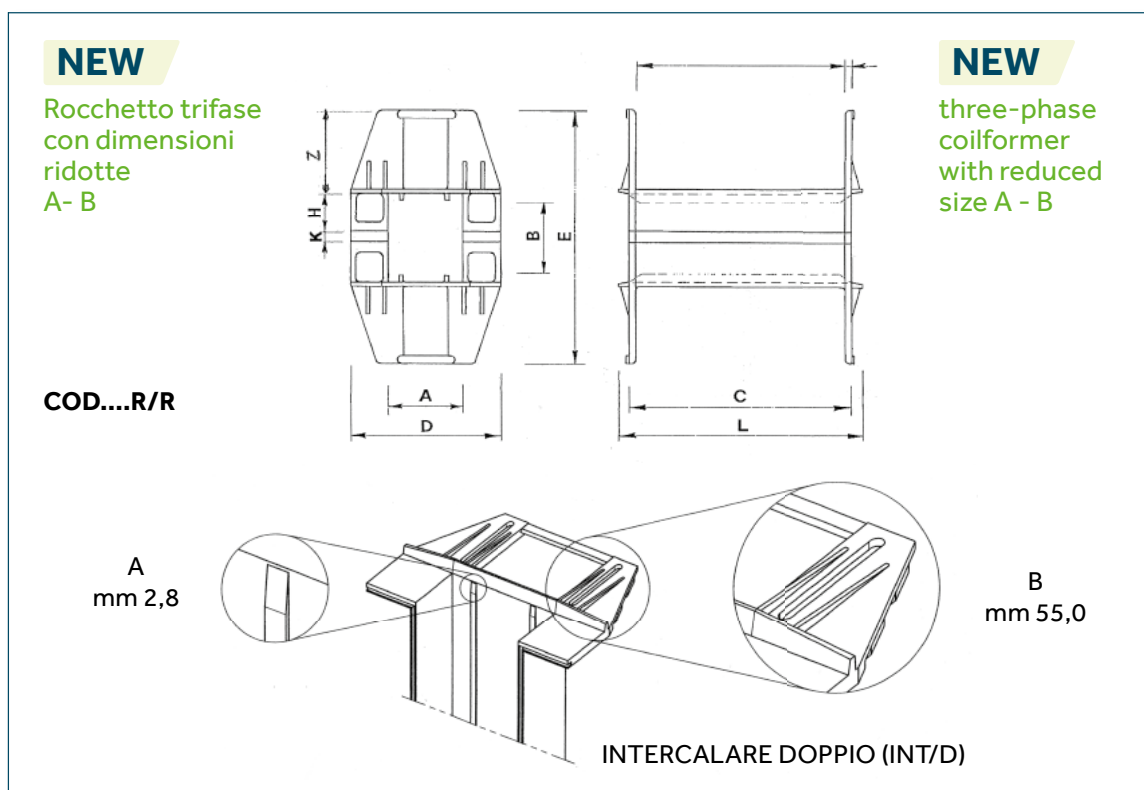

UI 210

Lam. 350X350

TYPE	DESCRIZIONE	REF.		A	B	C	D	E	F	H	S	L	Z	K	√
UI 210	SEMIROCCHETTO	70210R/R		72,2		209	139,5		199,8	34,1	4,0	229	55,0		
UI 210/65	INTERCALARE 70X72	INT7072	misure totali semirocchetto + intercalare assemblato	72,2	65,0	209	139,5	182	199,8		4,0	229		4	
UI 210/70	INTERCALARE 70X80	INT7080		72,2	70,0	209	139,5	188	199,8		4,0	229		10	
UI 210/82	INTERCALARE 70X90	INT7090		72,2	82,0	209	139,5	198	199,8		4,0	229		21	
UI 210/95	INTERCALARE 70X102	INT70102		72,2	95,0	209	139,5	208	199,8		4,0	229		35	
UI 210/102	INTERCALARE 70X110	INT70110		72,2	102,0	209	139,5	216	199,8		4,0	229		41	
UI 210/112	INTERCALARE 70X120	INT70120		72,2	112,0	209	139,5	226	199,8		4,0	229		51	
UI 210/122	INTERCALARE 70X132	INT70132		72,2	122,0	209	139,5	238	199,8		4,0	229		63	
UI 210/130	INTERCALARE 70X140	INT70140	72,2	130,0	209	139,5	246	199,8		4,0	229		69		
UI 210/....	INTERCALARE DOPPIO	INT70D	consente di aumentare a piacere il pacco lamellare								4,0				20
UI 210	FLANGIA INTERMEDIA	FL70/UI/R									5,8				

UI 240

Lam. 400X400

TYPE	DESCRIZIONE	REF.		A	B	C	D	E	F	H	S	L	Z	K	√
UI 240	SEMIROCCHETTO	80240R/R		81,7		239	159		229	26,5	4,0	259	54,5		
UI 240/62	INTERCALARE 80X82	INT8082	misure totali semirocchetto + intercalare assemblato	81,7	62	239	159	175	229		4,0	259		12	
UI 240/70	INTERCALARE 80X90	INT8090		81,7	70	239	159	183	229		4,0	259		20	
UI 240/80	INTERCALARE 80X100	INT80100		81,7	80	239	159	193	229		4,0	259		30	
UI 240/90	INTERCALARE 80X110	INT80110		81,7	90	239	159	203	229		4,0	259		40	
UI 240/100	INTERCALARE 80X120	INT80120		81,7	100	239	159	213	229		4,0	259		50	
UI 240/110	INTERCALARE 80X130	INT80130		81,7	110	239	159	223	229		4,0	259		60	
UI 240/120	INTERCALARE 80X140	INT80140		81,7	120	239	159	233	229		4,0	259		70	
UI 240/130	INTERCALARE 80X150	INT80150	81,7	130	239	159	243	229		4,0	259		80		
UI 240/....	INTERCALARE DOPPIO	INT80D	consente di aumentare a piacere il pacco lamellare								4,0				20
UI 240	FLANGIA INTERMEDIA	FL80/UI/R									5,8				

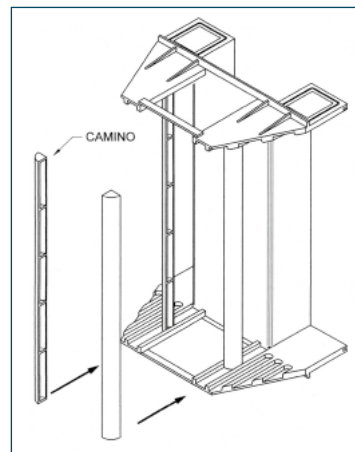
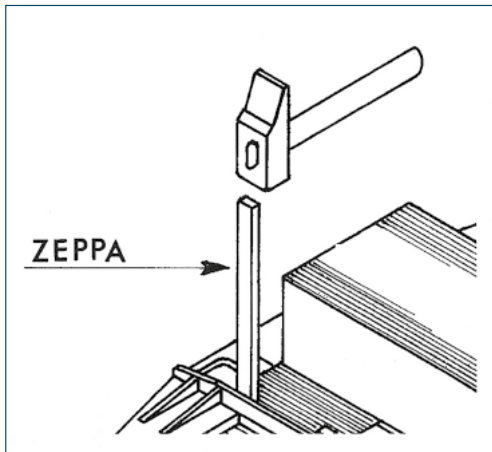

ZEPPE

TYPE	REF.	L	spessore
ZEPPA 60	ZEPPA60	174	da 4 a 5,5
ZEPPA 70	ZEPPA70	204	da 4 a 5,5
ZEPPA 80	ZEPPA80	234	da 4 a 5,5

CAMINI CLASSICI

TYPE	REF.	L	spessore	UI
CAMINO 60	CAM 60	174	10	UI 180
CAMINO 70	CAM 70	204	10	UI 210
CAMINO 80	CAM 80	234	10	UI 210
CAMINO 100	CAM 100	296	10	UI 300

STECHE / DOG'S BONE

CARATTERISTICHE MECCANICHE

Contrazione alla rottura	MPa	450
Allungamento alla rottura	%	2
Modulo di elasticità	MPa	40000

CARATTERISTICHE ELETTRICHE

Rigidità dielettrica		
- Trasversale	KV/mm	12
- Longitudinale	KV/mm	50
Fattore di dissipazione a 50Hz		$13 \cdot 10^{-3}$
Assorbimento d'acqua dopo 24 ore	%	0,3
Permeabilità E,50	Hz	0,5

CARATTERISTICHE TERMICHE

Temperatura limite - classe H -	°C	180
Coefficiente di dilatazione lineare	mm/M*°C	$8 \cdot 10^{-6}$
Massa di volume	g/cm ³	2,0

ALTRE

Percentuale di fibra vetro	%	60-70
----------------------------	---	-------

CAMINI TUB

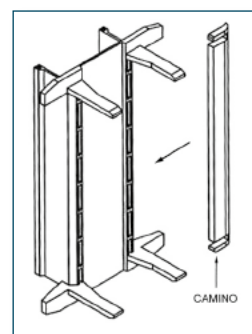

TYPE	REF.	L	spessore	UI
CAMINO 60	CAM60/T	194	10	UI 180
CAMINO 70	CAM70/T	233	10	UI 210
CAMINO 80	CAM80/T	225	10	UI 240
CAMINO 100	CAM100/T	286	10	UI 300

Stecche angolari

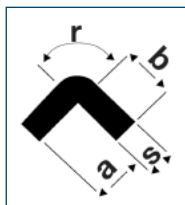

IN STECCHE
mt. 2,0

REF.	a mm	b mm	raggio r mm	s mm
STE 6X6	6	6	5	5,9
STE 7X7	7	7	6	7
STE 8X8	8	8	7	7,8
STE 10X10	10	10	9	9,8
STE 12X12	12	12	10	11,8

Profili classe h180° (dog's bone)

REF.	a mm	b mm
PRO 6X8	6	8
PRO 8X10	8	10
PRO 10X12	10	12
PRO 10X14	10	14
PRO 12X16	12	16
PRO 14X18	14	18
PRO 16X20	16	20
PRO 16X24	16	24

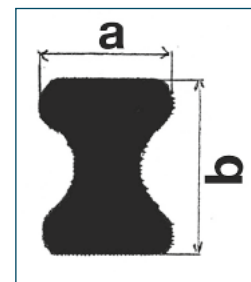

ROCCHETTI FAI DA TE "EI/UI" PATENTED

DO-IT-YOURSELF BOBIN / SPULENKORPER SELBER MACHEN

L'utilizzo del nuovo brevetto "FAI DA TE" ha modificato il modo tradizionale di produrre i trasformatori riducendo i costi e semplificandone la costruzione (il sistema fornisce un metodo conveniente e facile per costruire grandi rocchetti). Dove sarebbe impossibile costruire stampi per dimensioni fuori misura.

VANTAGGI

- Buona dissipazione al calore con effetto camino
- Apposite canaline permettono di inserire più stecche per fare più strati di avvolgimento.
- Alta resistenza termica (classe H e UL94VO)
- Utilizzabile per tutte le misure
- Bassi costi di consumo
- Pezzi disponibili a 45° e 90°

Prodotto in RP7 può arrivare a temperature elevate (vedi pagina classificazione materiali)

Utilizzando appositi distanziali si possono costruire innumerevoli misure a partire da 90 mm fino ad arrivare a 190 mm utilizzabili sia per la colonna sia per il pacco lamellare. Per l'altezza si utilizzano stecche angolari in vetroresina 10x10 mm di lunghezza fino a 2.5 mt.

Ove non sia possibile usare i distanziali si può utilizzare una lastra di vetroresina. Da inserire nelle apposite scanalature in modo da ottenere qualsiasi misura.

FAI DA TE 90°

PATENTED BREVETTATO

DISTANZIALE

DISTANZIALE REF.	L	B
90	43,5	65,5
100	53,5	75,5
110	63,5	85,5
120	73,5	95,5
130	80	102
140	90	112
150	100	122
160	110	132
170	120	142
180	130	152
190	140	162

FLEXIFORMER COIL SUPPORT SYSTEM ASSEMBLIES

The FlexiFormer coil support system provides a cost effective and easy method of building large transformer coil supports for cut core lamination widths 90mm to 190mm. The patented system consists of corner pieces, spacers and corner section profile which fit together to form a rigid structure upon which heavy windings can be produced.

Corner pieces are available in 90° or 45° profiles which offer alternative positioning of duct strips allowing for optimal air flow. Slot channels on the corner piece allow for duct strips to be placed in a fixed position. This eliminates the chance of the duct moving or falling out of the coil, maintaining the shape and integrity of the coil.

Up until now heavy windings have been produced by wrapping an insulation former around a winding mandrel. When the wound coil is removed from the mandrel there is the danger of the inside of the coil collapsing as there is nothing supporting it. Added complications can also come when trying to tilt the coil onto the lamination stack with the possibility of insulation damage where the mis-shapen coil snags against the laminated core. This can lead to potential puncturing of the coil insulation heightening the risk of shorted turns and earth faults.

FlexiFormer ensures that the coil is supported and does not collapse during this transition from winding machine to core building.

The whole assembly is rated at temperature Class H UL94 VO and can be included in systems where high temperature and flame retardant materials are specified.

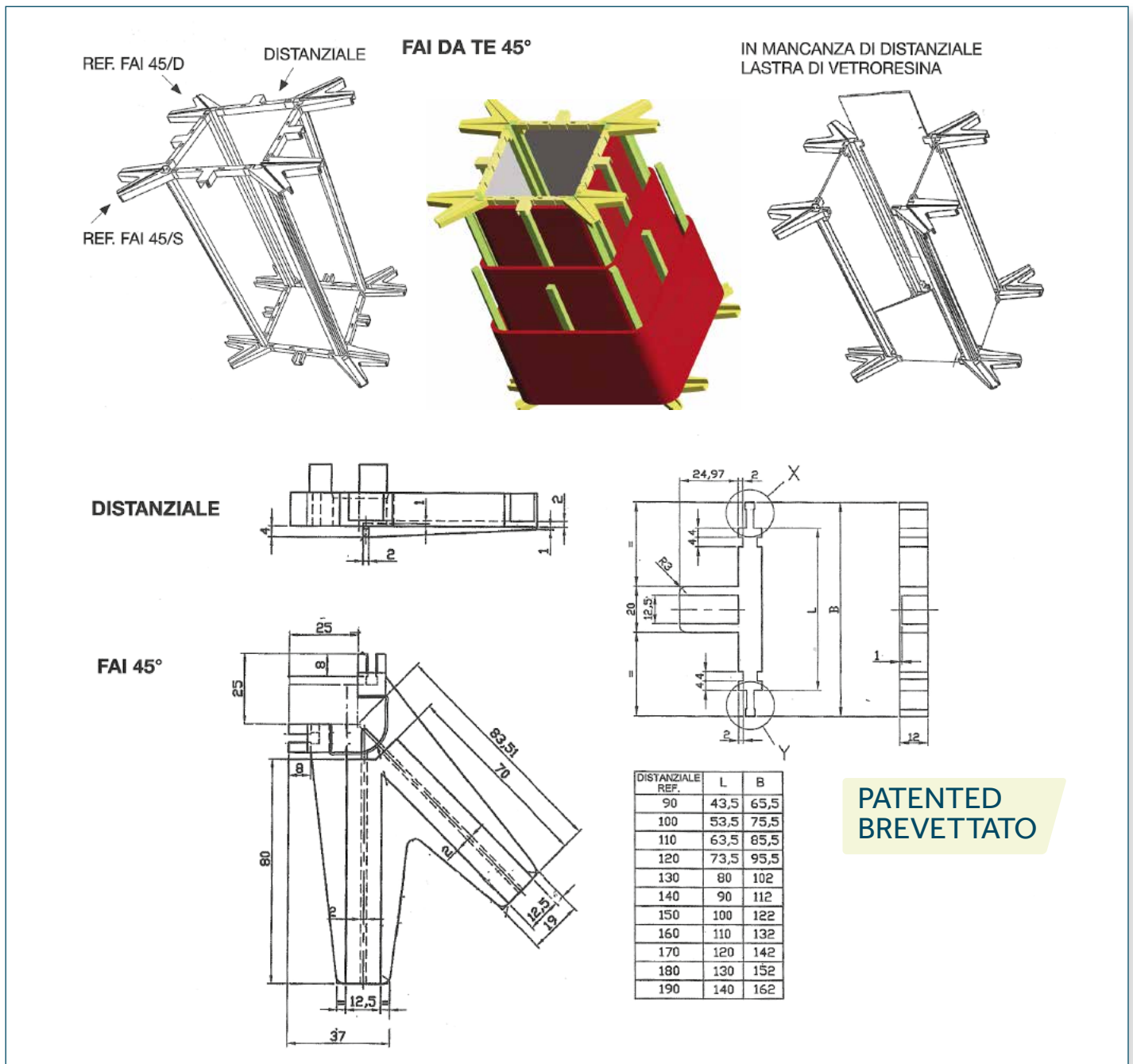

ROCCHETTI CON FLANGE A ELEMENTI COMPOSTI

Tipo RT Non impregnati 120°

Rocchetti eseguiti con cartone speciale di pura cellulosa fortemente pressato.
Flange rigidamente connesse al corpo, in grado di sostenere la spinta esercitata dall'avvolgimento.
Le flange possono essere corredate di finestrate e di terminali di ancoraggio.

Tipo RTV Impregnati 140°

Rocchetti di cartone come sopra ma impregnati con vernice isolante

Misure

Sezione minimo 3 x 3 mm lunghezza max 100 mm
Sezione max 500 x 500 mm lunghezza max 600 mm
Foro minimo Ø3 mm lunghezza max 100 mm
Foro max. Ø300 mm lunghezza max 600 mm.

CARCASSES AVEC JOUSES A ELEMENTS COMPOSES

Type RT Non imprégnés de peinture

Il s'agit de bobines produites en carton special de pure cellulose fortement pressée.
Joues rigidement reliées au corp, capables de soutenir la poussée exercée par l'enroulement.
Ces joues peuvent être équipées d'ouvertures et de picots de fixation.

Type RTV Imprégné de peinture

Bobines de carton, comme ci-dessus. mais imprégnées de peinture isolante

Dimension

Section minimal 3 x 3 mm, longueur maximale 100 mm.
Section maximal 500 x 500 mm. longueur maximale 600 mm.
Trou minimal Ø3 mm. longueur maximale 100 mm.
Trou maximal Ø 300 mm. longueur maximale 600 mm.

BUILT-UP FLANGED BOBBINS

Type RT Non impregnated

Bobbins made of highly dense special pure cellulose board.
Flanges the rigidly connected to the body, are able to resist the pressure used during winding.
They can be supplied with windows and anchorage terminals.

Type RTV Impregnated

Cardboard bobbins as above but impregnated with insulating varnish

Dimensions

Minimum section 3 x 3 mm length max 100 mm
Maximum section 500 x 500 mm length max 600 mm
Minimum section Ø3 mm length max 100 mm
Maximum section Ø300 mm length max 600 mm

SPULENKORPER MIT FLANSCHEN AUS ZUSAMMENGESETZTEN ELEMENTEN

Type RT Nicht imprägniert

Spulenkörper werden mit hoch gepressten Zellulose-pappe produziert.
Die flansche sind fest am Körper verknüpft und können die druck der spule widerstehen.
Sie können mit Öffnungen ausgestattet werden.

Type RTV Imprägniert

Kartonspulenkörper wie oben aber mit Isolierlack imprägniert.

Abmessungen

Mindestöffnung 3 x 3 mm mit max Länge 100 mm.
Max Oeffnung 500 x 500 mm mit max Länge 600 mm.
Mindestausschnitt Ø3 mm mit max. Länge 100 mm.
Höchstausschnitt Ø300 mm mit max. Länge 600 mm.

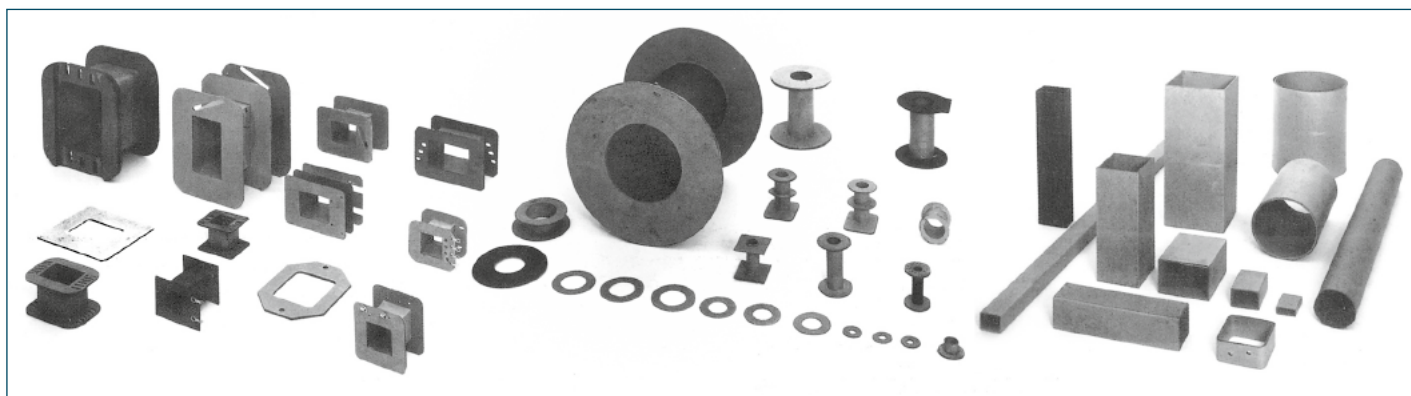

**Non ti preoccupare del fallimento.
Devi solo avere ragione una volta.**

**SPULENKÖRPER FÜR FERRIT
COILFORMS FOR FERRITES
CARCASSES POUR FERRITES
ROCCHETTI PER FERRITI**

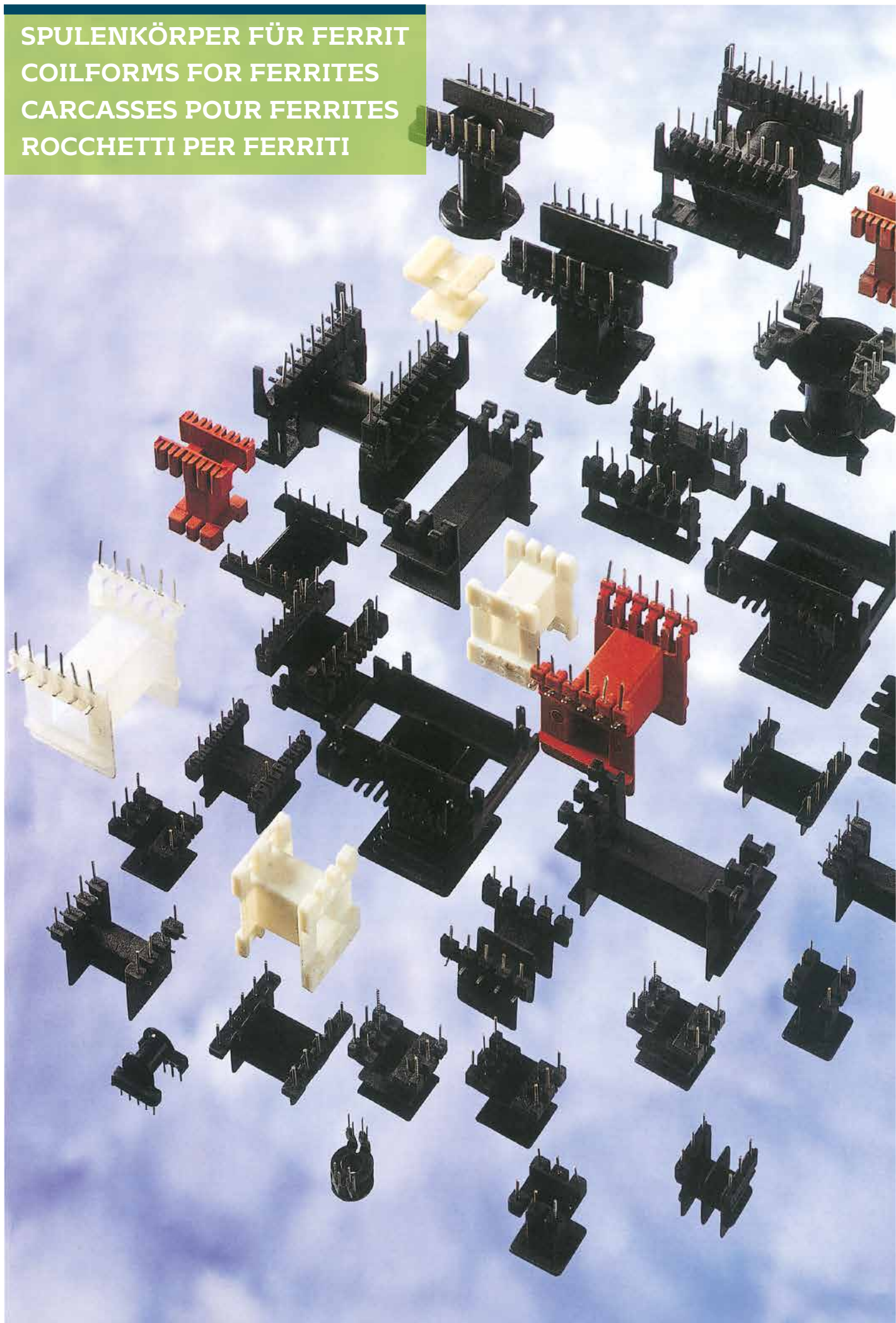

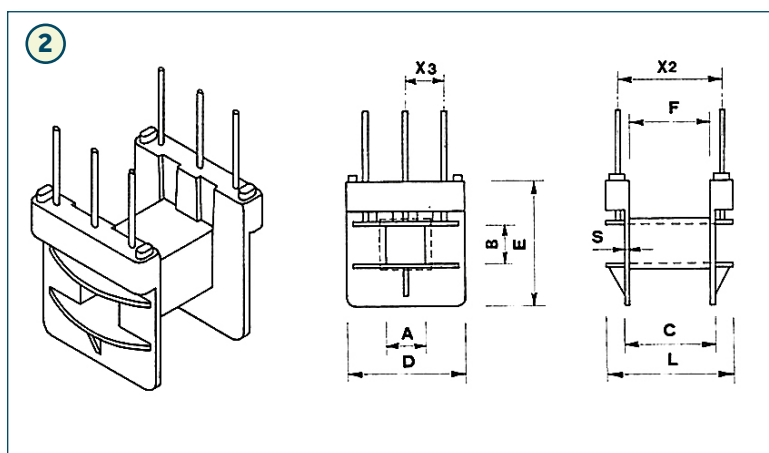
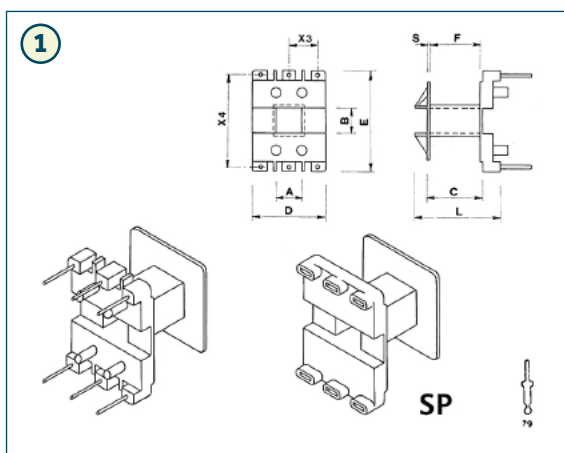

EE 19

TYPE	REF.	a	b	c	d	e	f	g	h	x2	x3	x4	S	L	numero term.	disegno
E 19V verticale	E 19V/1-2	5,3	5,3	10,8	14,5	20,0	9,8	4,5	4,5		5,5	18,5	0,5	16,5	2x3	1 con PINS 0,8
E 190 orizzontale	E 190/1-2	5,3	5,3	10,8	14,5	16,2	9,8	4,4	4,4	12,5	5,0		0,6	16,5	2x3	2 con PINS 0,8
E 19V verticale	E 19V/1SP	5,3	5,3	10,8	14,5	20,0	9,8	4,5	4,5		5,5	18,5	0,5	16,5	2x3	1

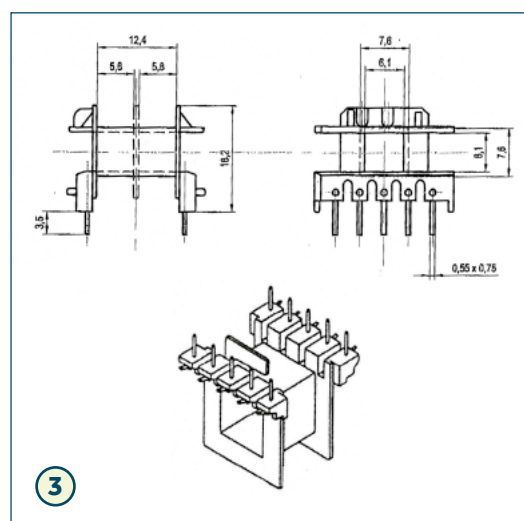
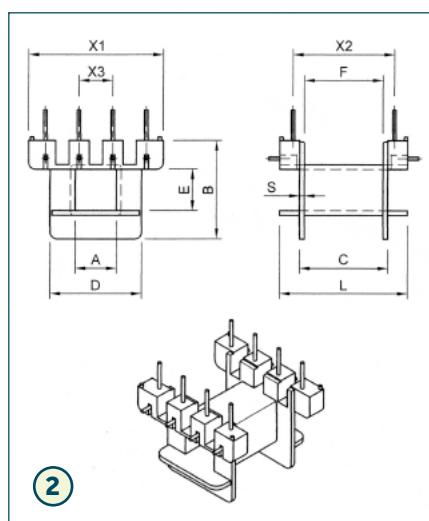
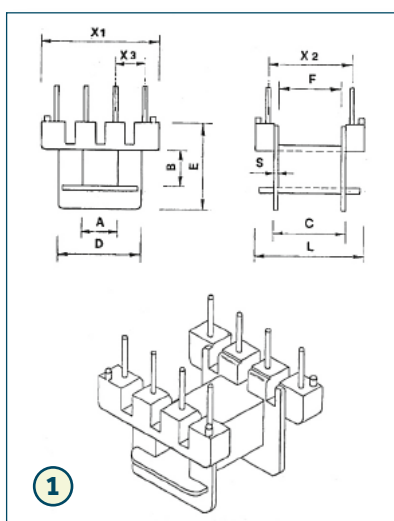

EE 20

TYPE	REF.	a	b	c	d	e	f	g	h	x1	x2	x3	S	L	numero term.	disegno
EE 20/8 orizzontale	EE 20/8/1-2	6,1	6,1	13,5	13,6	14,5	12,4	5,8	5,8	20	15,2	5	0,7	19,4	2x4	1
EE 20/8 orizzontale	EE 20/8/1-2	6,1	6,1	13,5	13,6	14,5	12,4	5,8	5,8	20	15,2	5	0,7	19,4	2x4	2
EE 20/10 orizzontale	EE 20/10/1-2	6,1	6,1	13,5	13,6	14,5	12,4	5,8	5,8	20	15,2	3,81	0,7	21,0	2x5	3

ROCCHETTI PER FERRITE IN TERMOPLASTICO

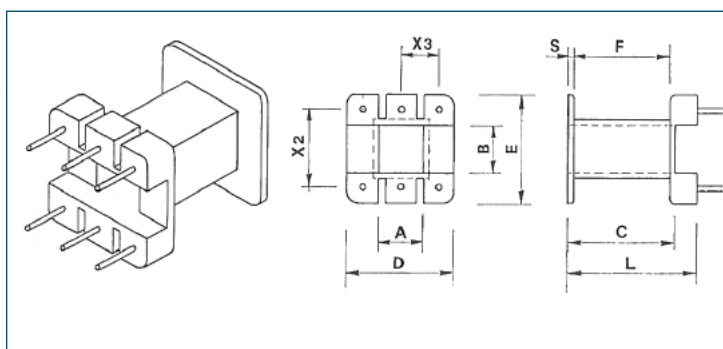

EE 20

TYPE	REF.	a	b	c	d	e	f	x2	x3	S	L	numero term.
EE 20 verticale	EE 20V	6,2	6,2	13,7	14	14	12,5	10	5	0,6	16,7	2x3

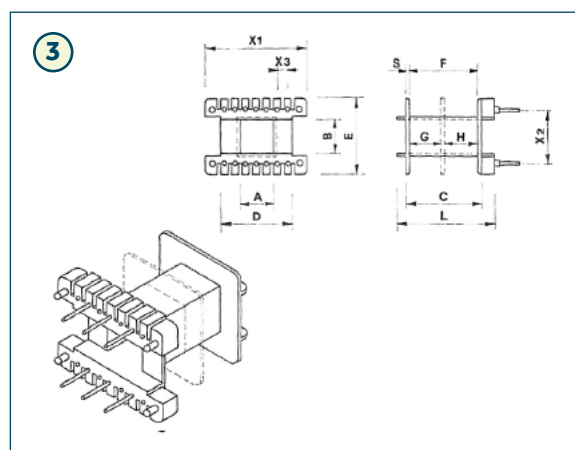
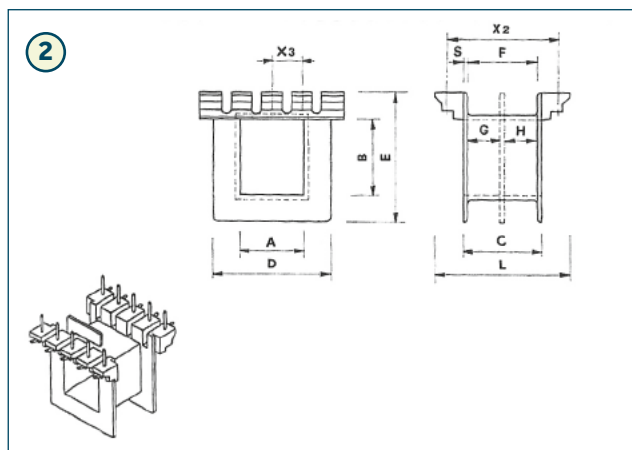
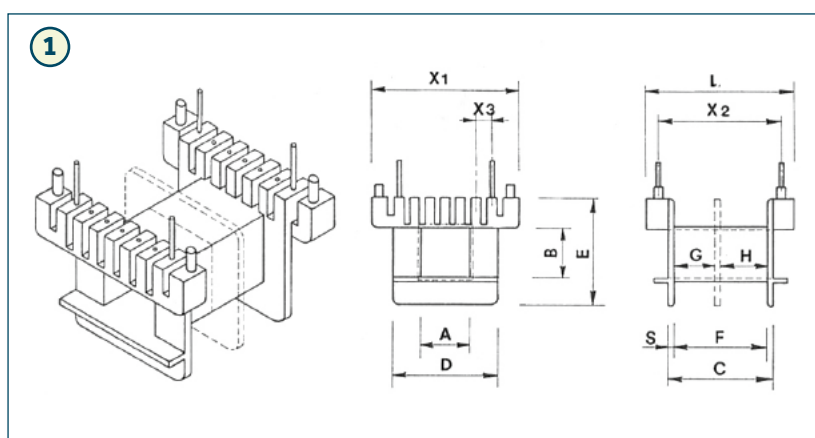

EE 25

TYPE	REF.	a	b	c	d	e	f	g	h	x1	x2	x3	S	L	numero term.	disegno
E 25 orizzontale	E255O/1-2	7,8	7,8	17,2	17,0	17,6	15,6	7,4	7,4	24,0	20,0	2,5	0,8	24,0	2x9	1
E 25 orizzontale	E25O/1-2	7,7	7,7	18,0	17,0	20,0	16,4	7,8	7,8	25,0	20,0	5,0	0,8	23,0	2x5	2
E 25 verticale	E255V/1-2	7,7	7,7	17,4	17,0	18,0	15,9	7,5	7,5	24,3	13,0	2,5	0,75	23,0	2x7	3

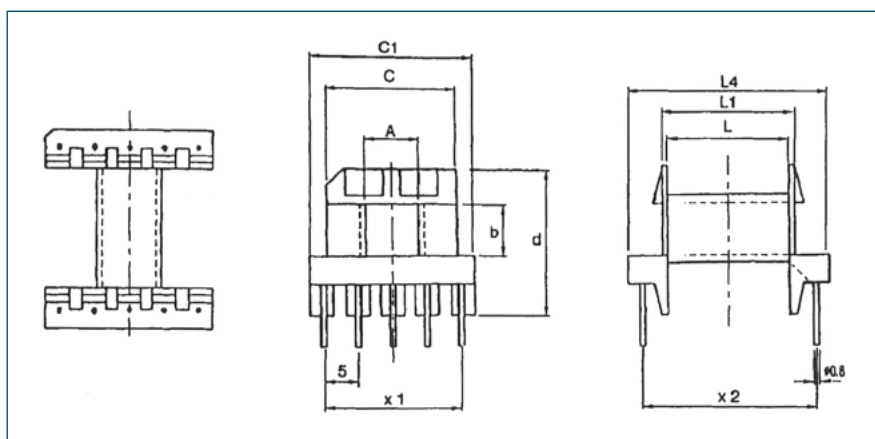

EE 30

TYPE	REF.	a	b	c	c1	d	L	L1	L4	x1	x2
E 30/10 orizzontale	E300/1-2/10	7,7	7,7	19,0	24,0	19,0	17,1	18,9	29,0	20,0	25,2

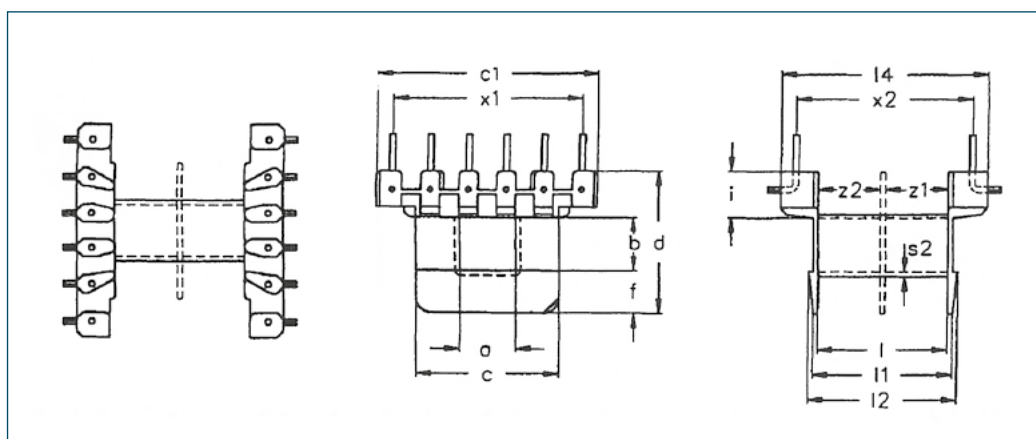

EE 30

TYPE	REF.	a	b	c	d	e	f	l	L	L1	L2	L4	S2	Z1	Z2	x1	x2
E 30/12 orizzontale	E300/1-2/12	7,5	7,5	19,1	29,5	19,5	5,7	6,3	17,3	19,0	19,8	27,7	0,85	8,15	8,15	20,25	25,0

Devi ardere con un'idea, un problema o un errore che vuoi correggere... se non sei abbastanza appassionato fin dall'inizio, non mollerai mai!

“Devi credere in te stesso quando nessun altro lo fa: questo ti rende un vincitore.”

ROCCHETTI PER FERRITE IN TERMOPLASTICO EE-UU

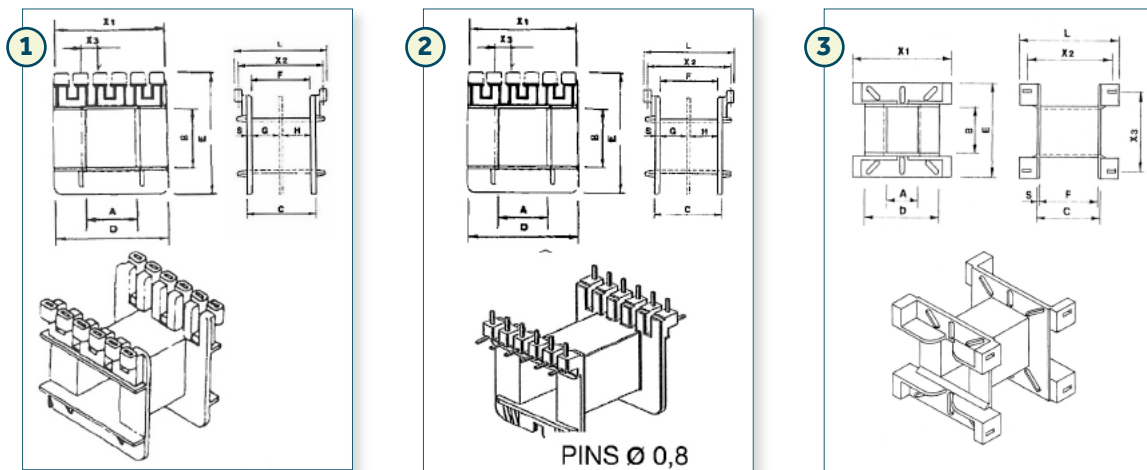

EE 32

EE 42

TYPE	REF.	a	b	c	d	e	f	g	h	x1	x2	x3	S	L	numero term.	disegno
E 32 orizzontale	E32O/1SP	9,3	13,2	19	21,7	27,0	17,5			29,0	25,0	22,5	0,65	28,8	2x2	3
E 32 orizzontale	E32O/1-2	10,0	13,0	19	22,0	30,5	17,4	7,4	9,2	30,0	27,5	5	0,8	30,5	2x6	1
E 42/15 orizzontale	E42/15O/1-2	13,2	15,7	28	29,3	34,0	25,8	10,9	14,2	30,0	35,5	5	1	37,4	2x6	1
E 42/20 orizzontale	E42/20O/1	12,5	20,6	29	29,0	38,6	26,0			29,0	25,0	5	1	38,0	2x7	2

ROCCHETTI PER FERRITI SERIE ETD

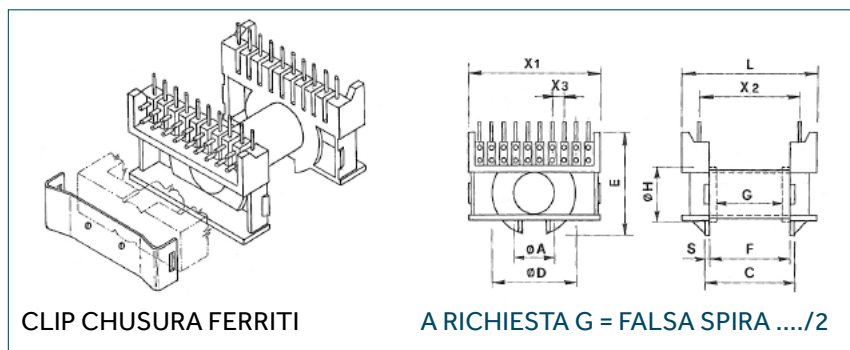

TYPE	REF.	a	c	d	e	f	g	l	s	x1	x2	x3	Ø PIN	numero term.	CLIPS
ETD 2901	ETD 2901/1	10,2	21,5	21,5	21,0	20,0		35,0	1,0	35,5	26,0	3,7	0,8	1x7 1x6	■
ETD 3401	ETD 3401/1	11,5	25,0	25,0	34,5	21,5	15,5	42,0	1,2	39,5	25,0	5	0,8	2x7	■
ETD 3901	ETD 3901/1	13,0	28,8	28,8	37,0	26,4	20,4	46,8	1,3	44,4	30,5	5	0,8	2x8	■
ETD 4401	ETD 4401/1	15,5	32,0	32,0	40,0	30,0	24,0	51,7	1,3	50,0	35,5	5	0,8	2x9	■
ETD 4901	ETD4901/1	17,0	36,0	36,0	42,5	33,0	27,5	57,0	1,3	54,0	40,0	5		2x10	■

TYPE	REF.	CLIP PER CHIUSURA FERRITI	
ETD 29	CLIPETD 29		
ETD 34	CLIPETD 34		
ETD 39	CLIPETD 39		
ETD 44	CLIPETD 44		
ETD 49	CLIPETD 49		

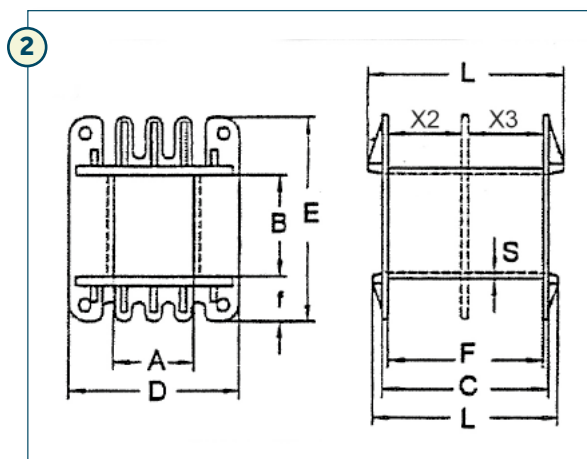
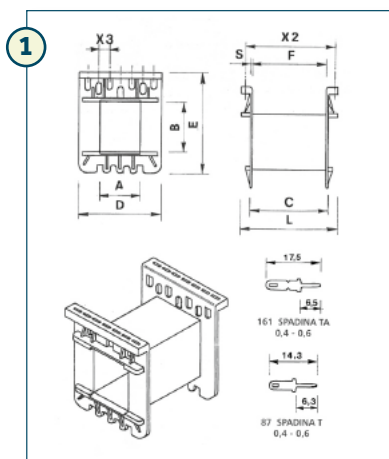

EE 55

TYPE	REF.	a	b	c	d	e	f	x1	x2	x3	S	L	numero term.	disegno
E 55/21	E 55/21,7/7	17,7	22	35,5	37,0	43,8	33,5	37	40	5,08	1	43,4	2x7	1
E 55/27	E 55/27,7/7	17,7	28	35,5	37,0	49,5	33,5	37	40	5,08	1	43,4	2x7	1
E 55/27	E 55V/27,7/1	18,0	28	35,5	37,0	49,5	33,5				1	42,5		2

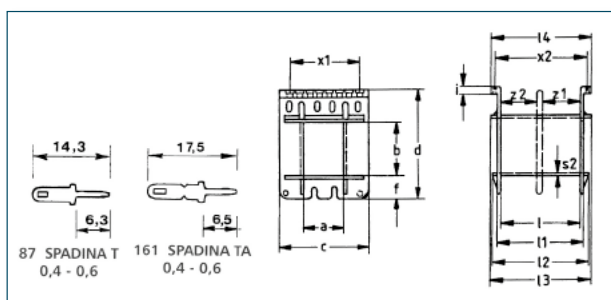

EE 65

EE 70

TYPE	REF.	a	b	c	d	f	l	L	L1	L2	L3	L4	S2	Z1	Z2	x1	x2	x3
E 65/27,8 gS	E 650	20,6	27,8	44,0	54,0	11,5	3,5	39,0	42,0	47,0	48,5	48,5	1,3	18,9	18,9	7x5	45,0	2x8
E 70/32,7 gS	E 700	23,4	32,7	46,0	58,0	12,0	3,5	38,5	41,5	47,5		53,5	1,1	18,5	18,5	8x5	50,0	2x9

ROCCHETTO PER FERRITE UU

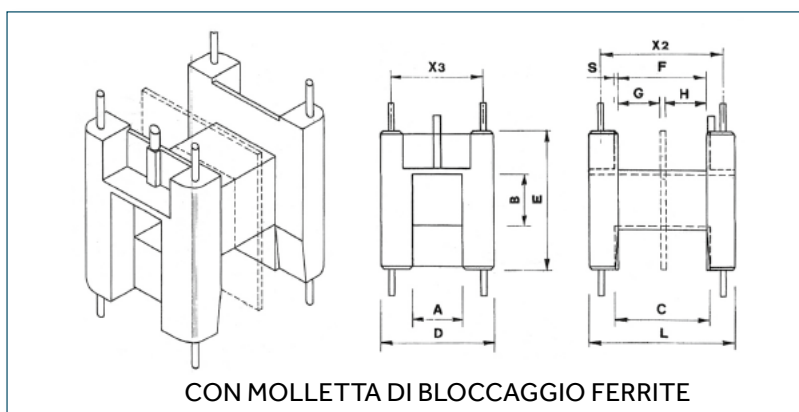

GUP 15

GUP 20

TYPE	REF.	a	b	c	d	e	f	g	h	x2	x3	S	L	numero term.
GUP 15 Orizzontale *	GUP15/1-2	7,2	5,7	11,4	16,3	16,5	10,0	4,6	4,6	15	13	1,0	18,4	2x4
GUP 20 Orizzontale *	GUP20/1-2	8,1	8,1	16,0	18,6	22,1	14,7	6,9	6,9	20	15	0,7	24,2	2x4

* DISPONIBILE CLIP IN TERMO PLASTICO BLOCCAGGIO FERRITE

CONTENITORI PER FERRITI VERTICALI

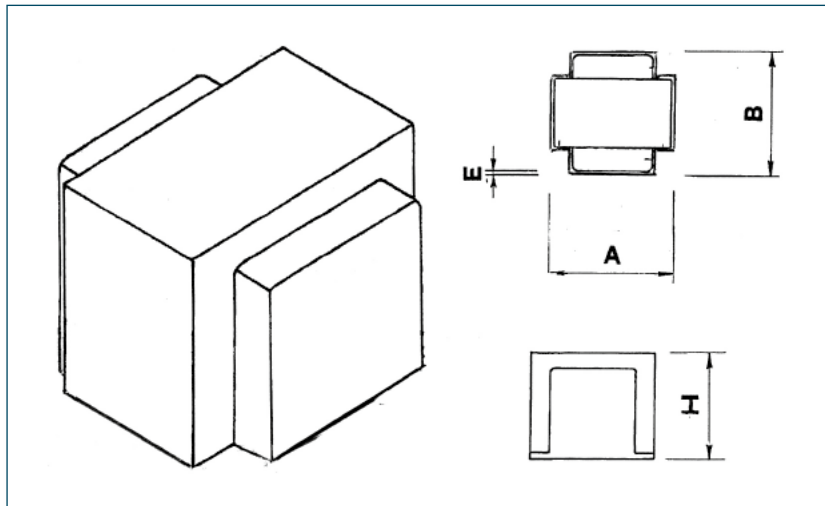

TYPE	REF.	A	B	H	E
EE19	SVE19	20,5	14	19,0	0,75
EE25	SVE25	29,0	27,5	32,0	1,0
EE32	SVE32	37,3	27,3	34,4	0,75
EE42/15	SVE42/15	48,5	39,5	50,0	1,0
EE42/20	SVE42/20	48,5	39,5	52,0	1,0

CONTENITORI PER FERRITI ORIZZONTALI

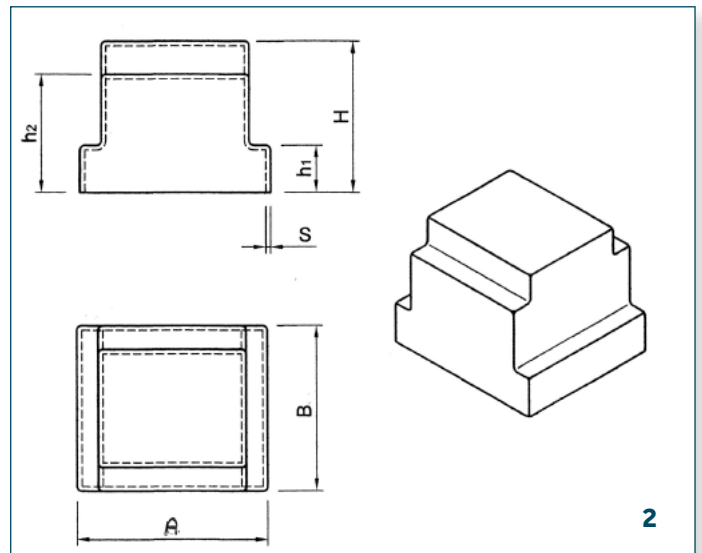
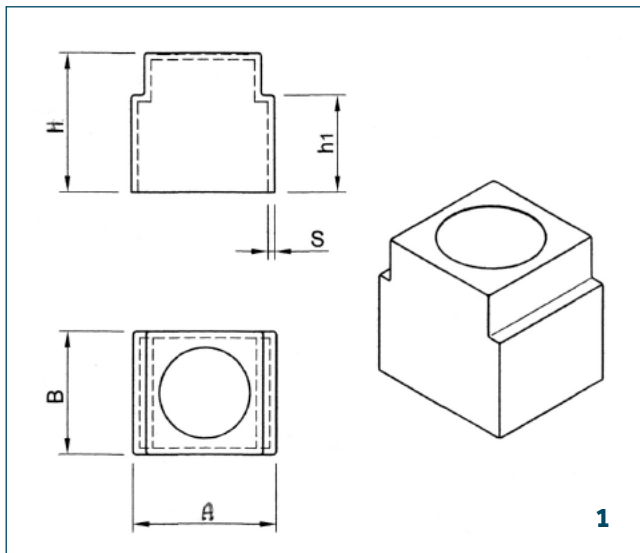

TYPE	REF.	A	B	H	S	disegno
EE12,5	SOE12,5	14,5	16,5	12,0	1	1
EE19	SOE19	16,5	20,0	21,0	1	1
EE20	SOE20	20,3	20,2	15,5	1	1
EE30	SOE30	30,1	33,2	20,8	1	1
EE32	SOE32	33,5	38,0	32,0	1	2

ARTICOLO	d	L	D
OU 15	1,5	2,0÷10,0	2,5
OU 20	2,0	2,0÷12,0	3,5
OU 22	2,2	2,5÷12,0	3,7
OU 25	2,5	2,5÷16,0	4,0
OU 30	3,0	2,0÷17,5	5,0
OU 35	3,5	3,0÷17,0	5,5
OU 40	4,0	2,0÷27,0	6,0
OU 45	4,5	4,5÷15,0	6,5
OU 50	5,0	3,5÷16,0	7,5
OU 60	6,0	4,0÷10,0	8,0

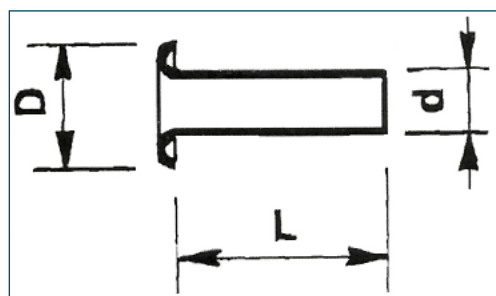

MISURE IN mm

MATERIALE OTTONE

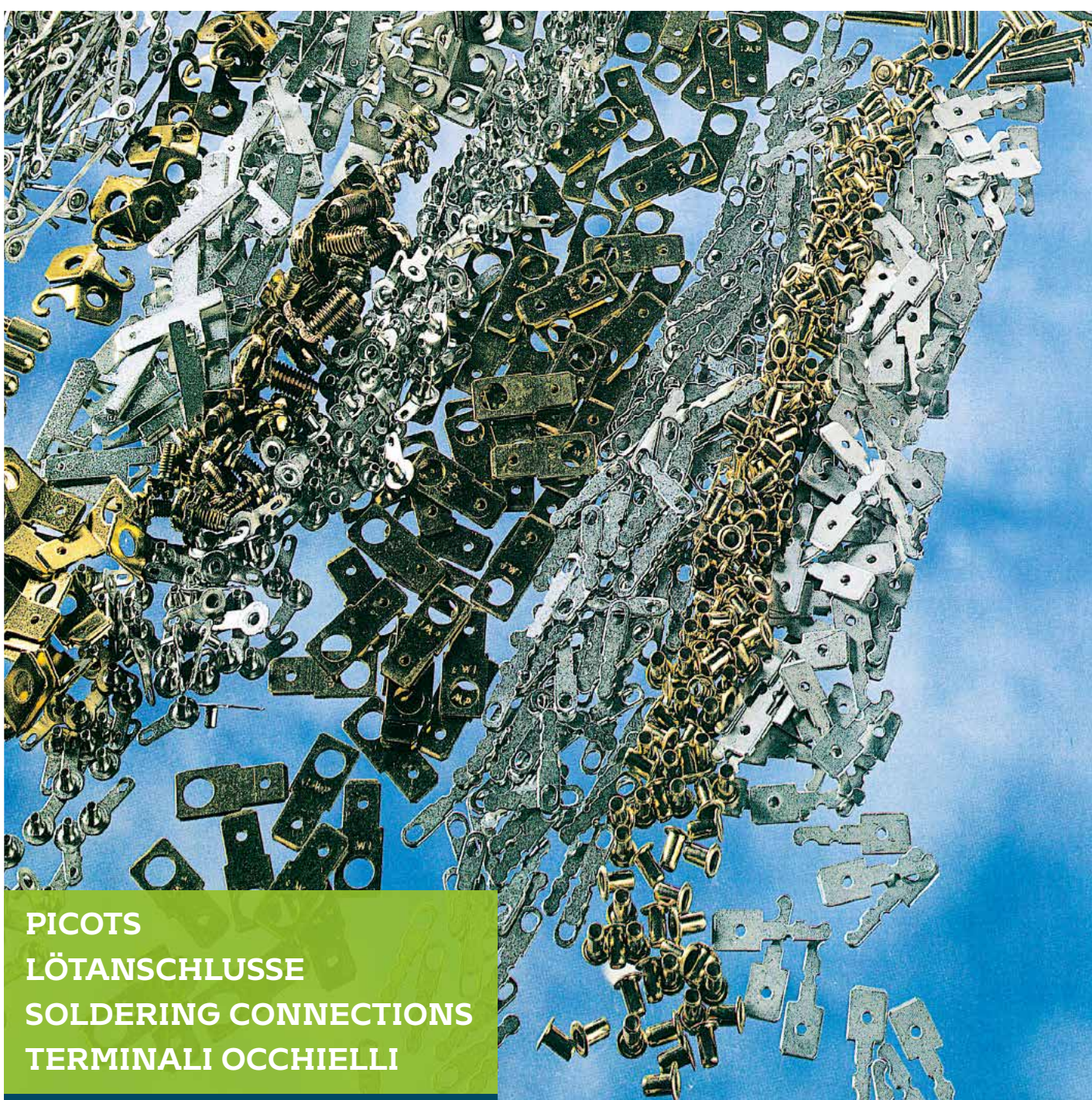

PICOTS
 LÖTANSCHLUSSE
 SOLDERING CONNECTIONS
 TERMINALI OCCHIELLI

TERMINALI

Pins - Picots - Lotanschlüsse

INDICATI PER ROCCHETTI MOD. E

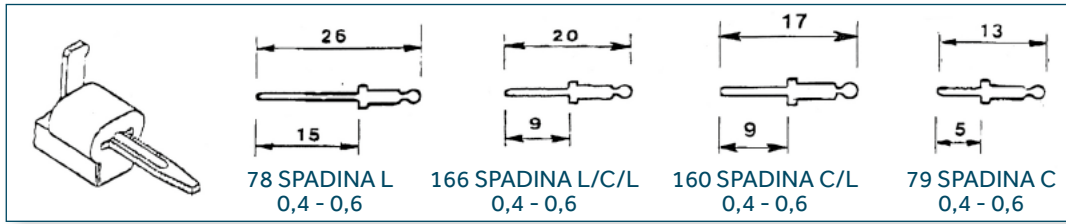

INDICATI PER ROCCHETTI MOD. F

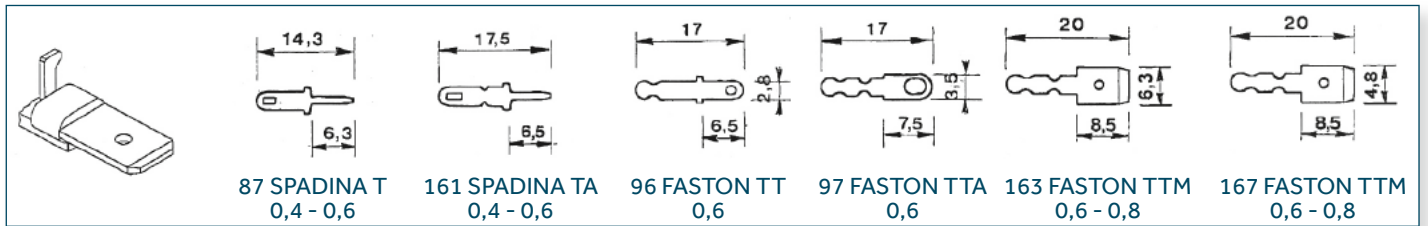

INDICATI PER ROCCHETTI MOD. E-T

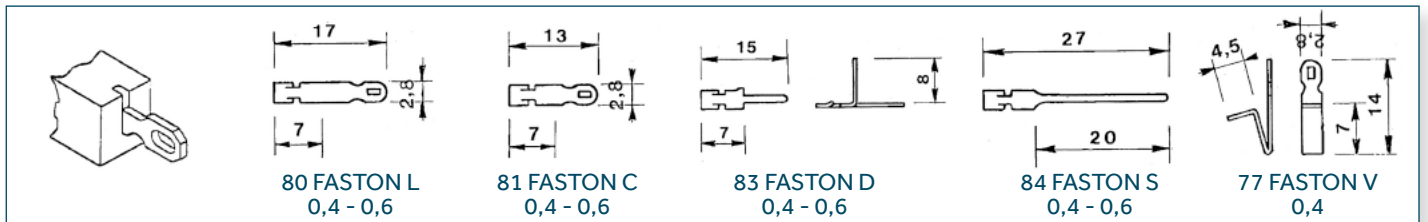

INDICATI PER ROCCHETTI MOD. A-R

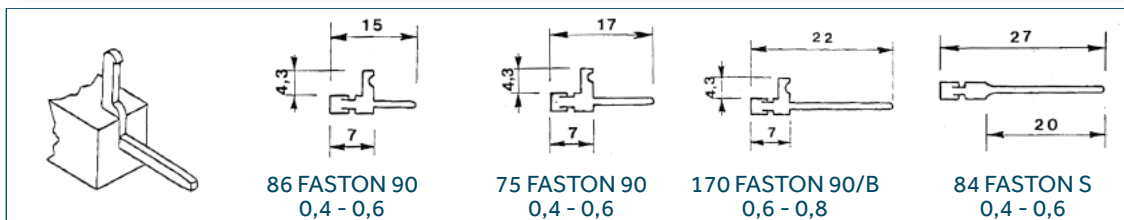
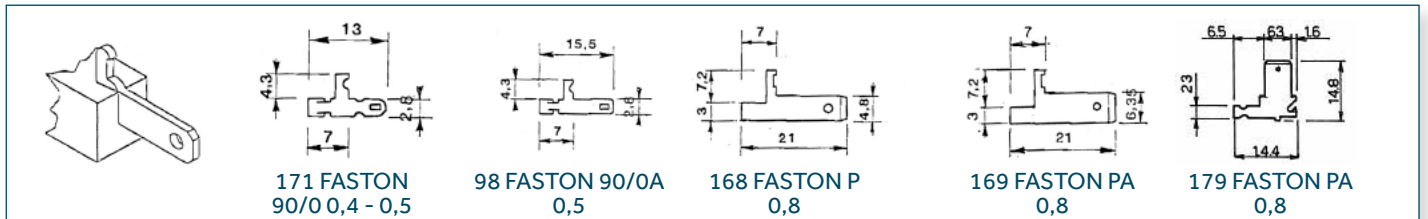

INDICATI PER ROCCHETTI MOD. D

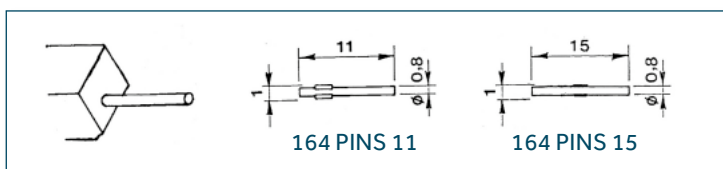

**BOITES-CONTAINEURS
VERGÜßHAUBEN
BOXES-POTTING
CONTENITORI**

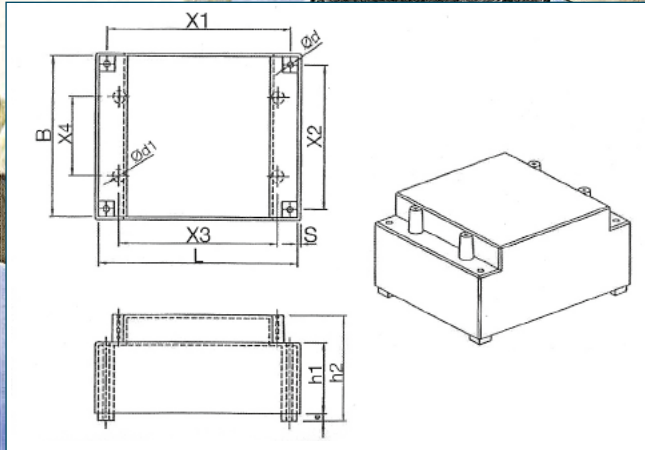
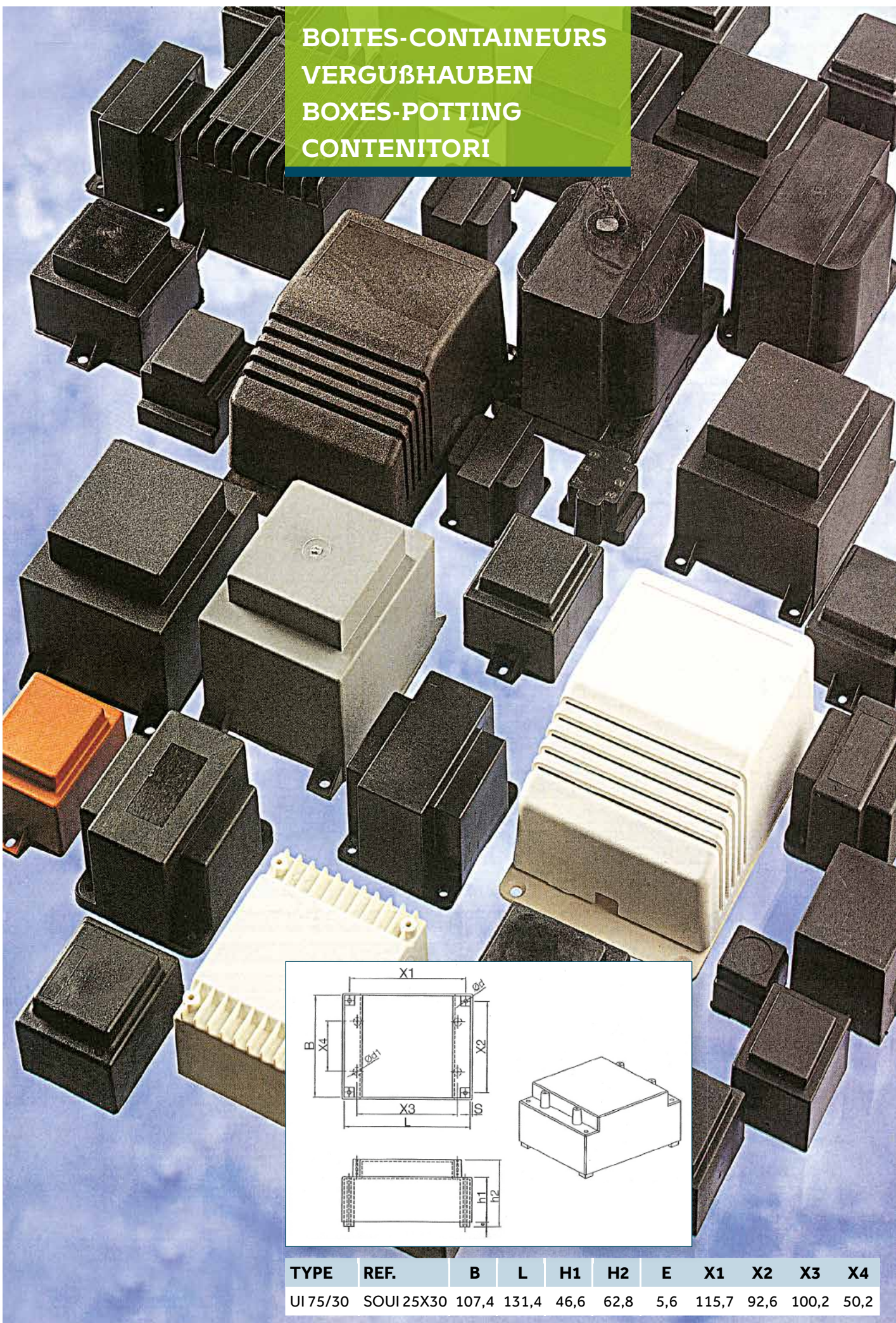

TYPE	REF.	B	L	H1	H2	E	X1	X2	X3	X4
UI 75/30	SOUI 25X30	107,4	131,4	46,6	62,8	5,6	115,7	92,6	100,2	50,2

CONTENITORI TIPO ORIZZONTALE

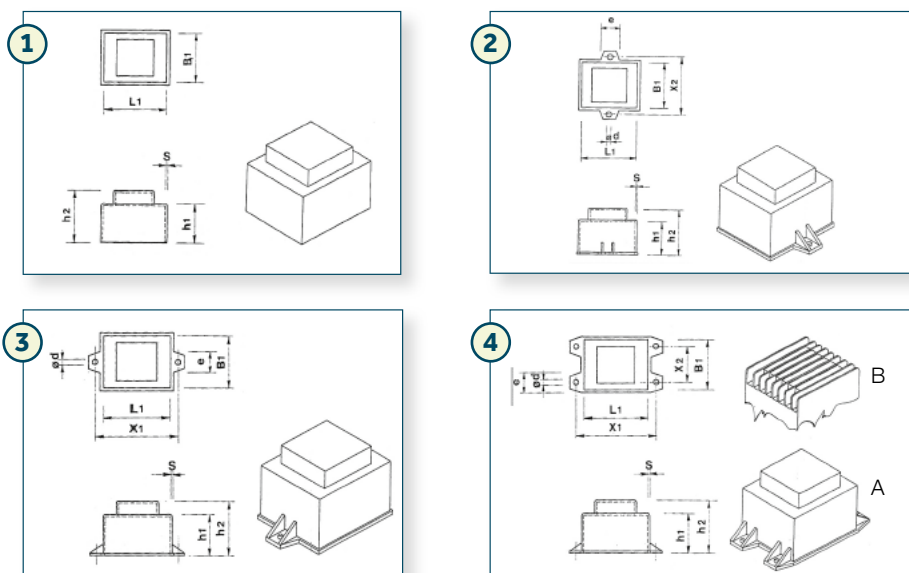

TYPE	REF.	B1	L1	h1	h2	s	c	d	e	x1	x2	disegno
EI 27X33	SO 10X10	28,5	34,5	20,7	26,1	1,1						1
EI 25X30	SO 10X10T	27,3	32,4	17,8	21,8	1,2						1
EI 25X30	SO 10X12T	27,3	32,4	19,8	23,8	1,2						1
EI 27X33	SO 10X15	28,5	34,0	25,4	30,5	1,2						1
EI 25X30	SO 10X15T	27,3	32,4	22,8	26,8	1,2						1
EI 25X30	SO 10X18T	27,5	32,4	25,8	29,8	1,2						1
EI 32X38	SO 13X13T	33,0	39,0	22,5	28,0	1,3						1
EI 34X40	SO 13X13	35,5	41,5	25,0	31,5	1,3		3	13,5	51,0		1-3
EI 34X40	SO 13X15	35,5	41,5	27,0	33,5	1,3		3	13,5	51,0		1-3
EI 34X40	SO 13X20	36,0	42,0	31,5	38,7	1,3		3	13,5	51,0		1-3
EI 35X42	SO 14X14	36,0	43,0	26,3	32,5	1,3		3	14,0	55,0		1-3
EI 40X48	SO 16X16	41,3	49,5	31,0	38,7	1,3		4	15,5	60,5	52,0	1-2-3
EI 40X48	SO 16X20	41,3	49,5	35,5	42,7	1,3		4	15,5	60,5	52,0	1-2-3
EI 40X48	SO 16X25	41,3	49,5	39,5	47,2	1,3		4	12,0	60,5	52,0	1-2-3
EI 45X54	SO 18X18	46,0	55,0	32,5	41,0	1,3		3	14,0	68,5		1-3
EI 45X54	SO 18x28	47,0	55,3	42,3	51,3	1,4		4	14,0	68,5		3
EI 50X60	SO 20X20	51,2	61,2	38,2	47,4	1,4		4	10,0	72,5	43,5	4A
EI 50X60	SO 20X25	51,2	61,2	43,2	52,2	1,4		4	10,0	72,5	43,5	4A
EI 50X60	SO 20X30	51,2	61,2	48,6	57,5	1,4		4	10,0	72,5	43,5	4A
EI 55X66	SO 22X22	56,0	67,0	42,0	56,4	1,5		4	10,0	79,0	48,0	4A
EI 55X66	SO 22X25	56,0	67,0	44,6	59,0	1,5		4	10,0	79,0	48,0	4A
EI 55X66	SO 22X30	56,0	67,0	50,0	64,5	1,5		4	10,0	79,0	48,0	4A
EI 55X66	SO 22X35	56,0	67,0	55,0	69,5	1,5		4	10,0	79,0	48,0	4A
EI 62,5X75	SO 25X25	64,8	77,3	47,0	58,8	1,7		4	11,0	90,5	56,5	4B
EI 62,5X75	SO 25X30	64,8	77,3	52	64,8	1,7		4	11,0	90,5	56,5	4B
EI 62,5X75	SO 25X40	64,8	77,3	57,0	75,0	1,7		4	11,0	90,5	56,5	4B
EI 65X78	SO 26X40	64,4	79,8	62,3	73,0	1,7		4	10,6	89,5	57,5	4A
EI 70X84	SO 28X29,5	71,4	85,4	51,4	63,0	1,7		5	10,5	97,5	60	4A
EI 70X84	SO 28X43,5	71,4	85,4	65,4	77,0	1,7		5	10,5	97,5	60	4A
EI 80X96	SO 32X45,5	81,5	97,5	70	86,0	2,2		5	14,5	115	70	4A
EI 80X96	SO 32X59,5	81,5	97,5	85	100,0	2,2		5	14,5	115	70	4A

CONTENITORI TIPO ORIZZONTALE CON PORTA MORSETTO

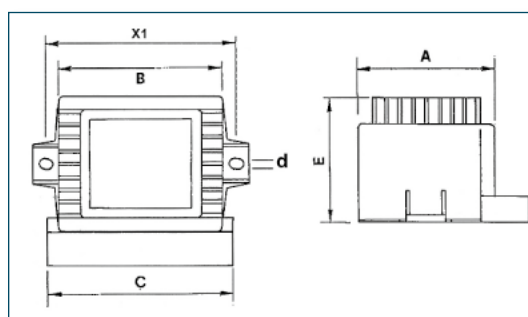

TYPE	REF.	A	B	C	E	S	d	x1
EI 34X40	SO 13X15CM	36,0	42,0	50,0	33,5	1,3	3	51,0
EI 34X40	SO 13X20CM	36,0	42,0	50,0	38,7	1,3	3	51,0
EI 45X54	SO 18X18 CM	47,0	56,0	65,0	42,0	1,3	3	67,0
EI 62,5X75	SO 25X30 CM	64,0	77,3	77,0	75,0	1,3	4	90,5

CONTENITORI TIPO VERTICALE

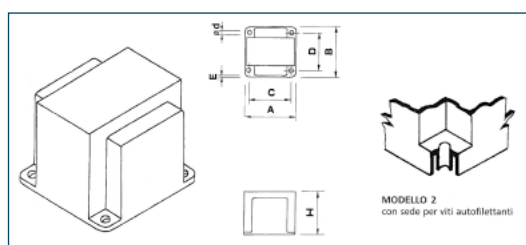

TYPE	REF.	a	b	c	d	e	Ød	h
EI 27X33	SV 10X10	38	31	32	20	1,4	3,5	30,3
EI 27X33	SV 10X15	38	35	32	25,5	1,4	3,5	30,3
EI 34X40	SV 13X15	44,5	37,3	36	25,5	1,1	3,5	37,7
EI 40X48	SV 16X16	53,5	42	43,5	29,5	1,5	3,5	44,0
EI 40X48	SV 16X20	53,3	45,5	43,5	36,5	1,5	3,5	44,5
EI 40X48	SV 16X25	53,8	51,2	43,8	41,2	1,5	3,5	44,5
EI 58X68	SV 22X25	76,0	54,0	62,5	42,5	1,5	3,5	63,0
EI 70X84	SV 28X21	96,0	65,0	76,0	48,0	2,0	6,0	76,0

SCATOLINI VERTICALI/ORIZZONTALI

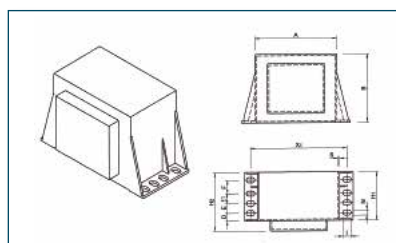

TYPE	REF.	A	B	D	E	F	X1	H2	H1	N	I	S	E1
EI 45X54	SV/O18X18	57,5	48,0	11,25	10,08		67,0	42,1	33,1	3,75	6,45	1,25	
EI 50X60	SV/O20X20	66,0	54,0	8,50	11,0		75,0	46,0	34,5	5,40	9,00	1,40	
EI 50X60	SV/O20X25	66,0	54,0	8,50	11,0		75,0	51,0	39,5	5,40	9,00	1,40	13,50
EI 50X60	SV/O20X30	66,0	54,0	8,50	11,0		75,0	56,0	44,5	5,40	9,00	1,40	13,50
EI 55X66	SV/O22X22	69,5	59,0	10,65	13,0		81,8	49,0	39,8	4,90	8,00	1,80	

ROCCHETTI BASSO PROFILO

UI 30

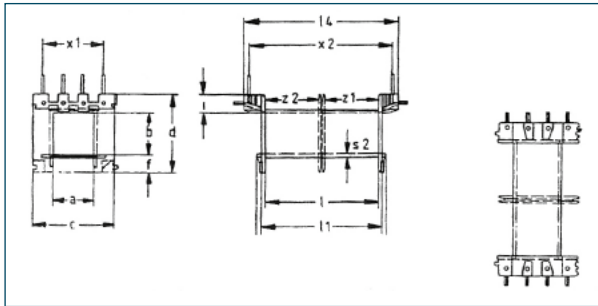

UI 39

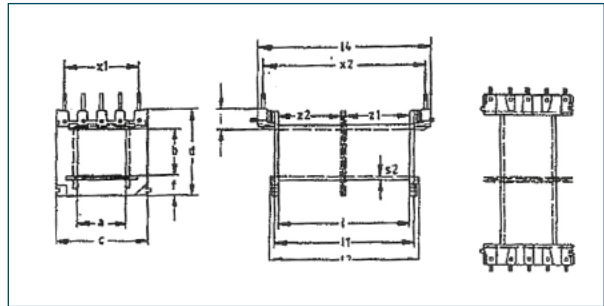

TYPE	KA	A	B	C	D	F	I	L	L ₁	L ₃	L ₄	S ₂	Z ₁	Z ₂	X ₁	X
UI 30/5,5 (8 pins)	1-2	10,4	5,5	20,0	14,6	4,4	4,7	28,0	29,6	31,2	38,0	0,9	13,3	13,3	3x5	35,0
UI 30/7,5 (8 pins)	1-2	10,4	7,5	20,0	16,6	4,4	4,7	28,0	29,6	31,2	38,0	0,9	13,3	13,3	3x5	35,0
UI 30/10,5 (8 pins)	1-2	10,4	10,5	20,0	19,6	4,4	4,7	28,0	29,6	31,2	38,0	0,9	13,3	13,3	3x5	35,0
UI 30/16,5 (8 pins)	1-2	10,4	16,5	20,0	25,6	4,4	4,7	28,0	29,6	31,2	38,0	0,9	13,3	13,3	3x5	35,0

TYPE	KA	A	B	C	D	F	I	L	L ₁	L ₃	L ₄	S ₂	Z ₁	Z ₂	X ₁	X
UI 39/8 (10 pins)	1-2	13,6	8,1	25,9	19,9	5,7	6,1	36,8	38,6	41,8	47,6	1,0	17,7	17,7	4x5	45,0
UI 39/10,2 (10 pins)	1-2	13,6	10,2	25,9	22,0	5,7	6,1	36,8	38,6	41,8	47,6	1,0	17,7	17,7	4x5	45,0
UI 39/13,5 (10 pins)	1-2	13,6	13,5	25,9	25,3	5,7	6,1	36,8	38,6	41,8	47,6	1,0	17,7	17,7	4x5	45,0
UI 39/17 (10 pins)	1-2	13,6	17,0	25,9	28,8	5,7	6,1	36,8	38,6	41,8	47,6	1,0	17,7	17,7	4x5	45,0
UI 39/21 (10 pins)	1-2	13,6	21,0	25,9	32,8	5,7	6,1	36,8	38,6	41,8	47,6	1,0	17,7	17,7	4x5	45,0

Modello per circuito stampato con piedini tranciati saldabili.
Model for printed circuits with molded soldering pins.

SCATOLINO PER BASSO PROFILO

UI 30

TYPE	a	a1	b	b1	l	l1	x1	x2
SO UI 30/5,5	41,8	44,0	50,8	53,0	15,7	16,8	37,5	47,5
SO UI 30/7,5	41,8	44,0	50,8	53,0	17,7	18,8	37,5	47,5
SO UI 30/10,5	41,8	44,0	50,8	53,0	20,7	21,8	37,5	47,5
SO UI 30/16,5	41,8	44,0	50,8	53,0	26,7	27,8	37,5	47,5

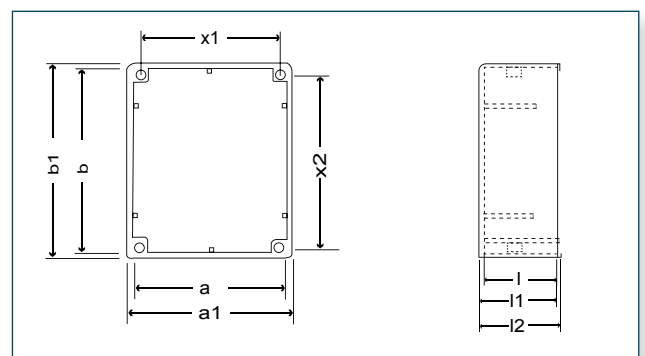

UI 39

TYPE	A	A1	B	B1	L	L1	X1	X2
SO UI 39/8	55,0	57,0	65,6	67,5	21,0	22,0	50,0	55,0
SO UI 39/10,2	55,0	57,0	65,6	67,5	22,6	23,6	50,0	55,0
SO UI 39/13,5	55,0	57,0	65,6	67,5	25,8	26,8	50,0	55,0
SO UI 39/17	55,1	57,5	65,6	67,5	29,4	30,6	50,0	55,0
SO UI 39/21	55,1	57,5	65,6	67,5	33,4	34,6	50,0	55,0

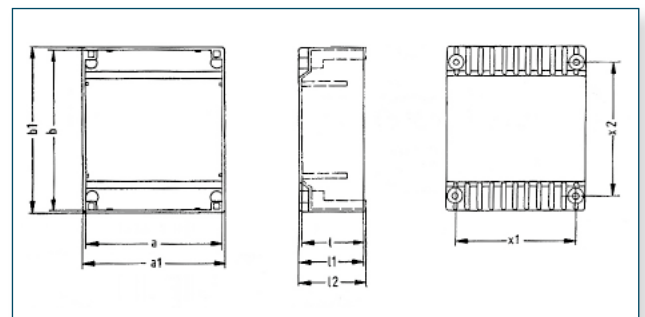

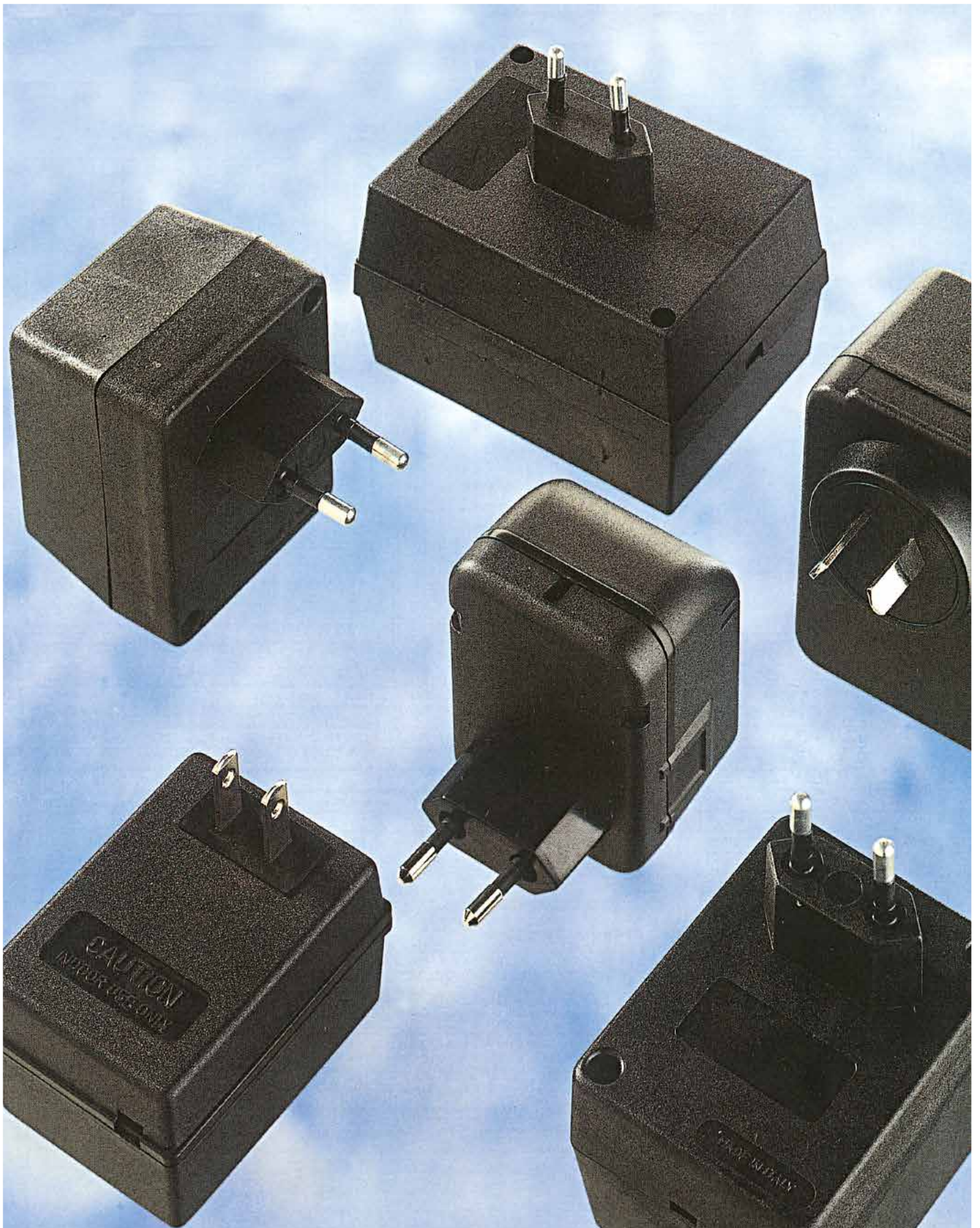

**NETZTEILKÄSTEN
BOÎTIERS POUR ALIMENTATEURS
BOX FOR LOCALS POWER SOURCE
SCATOLE PER ALIMENTATORI**

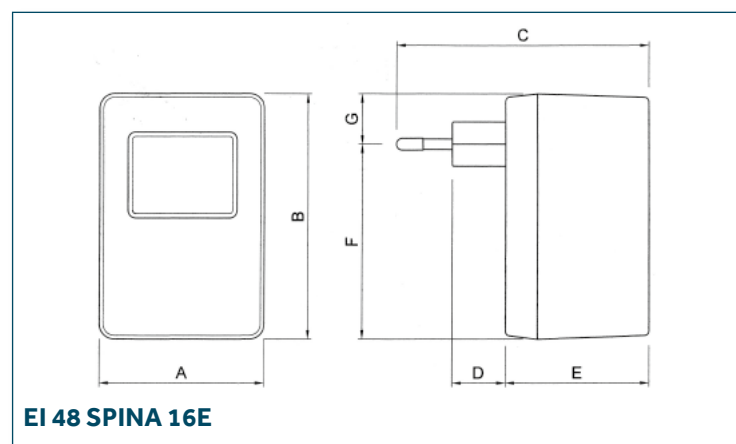
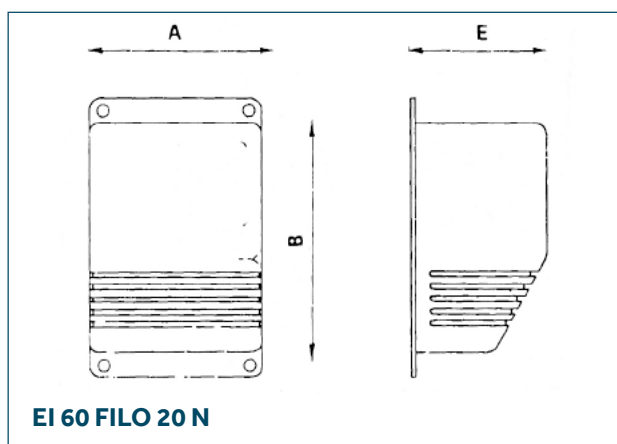
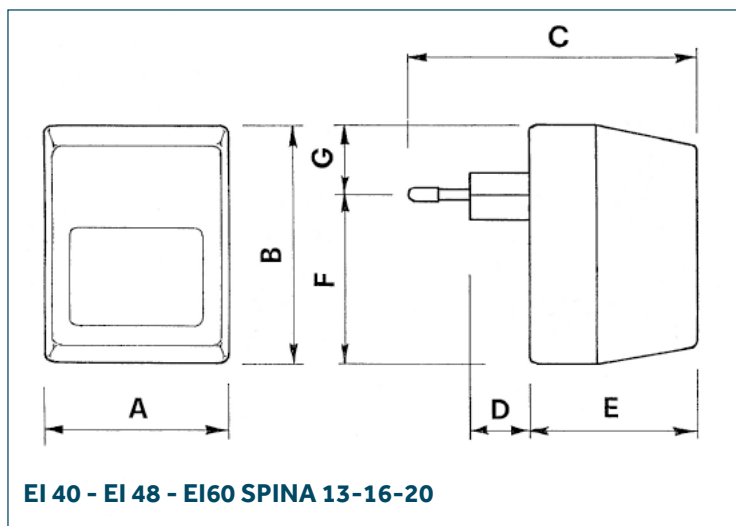
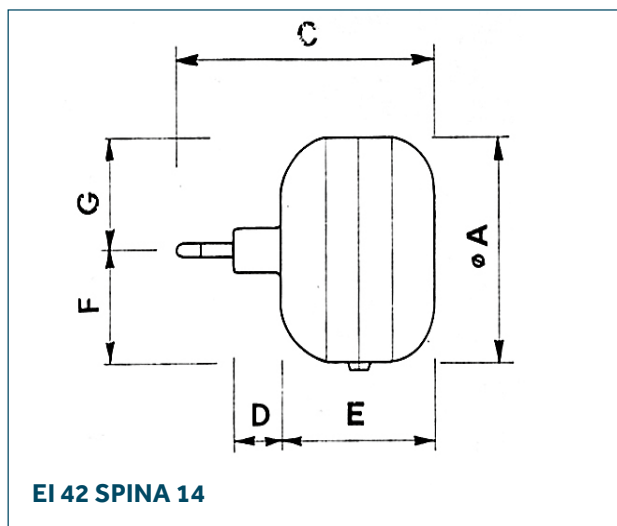

TYPE	REF.	a	b	c	d	e	f	g	Rocchetto
EI 42	SPINA 14	60		77	14	46	30	30	14x14
EI 60	FILO 20 N	76	97			57			20X20-20X25
EI 60	SPINA 2020	65	90	91	18	55			20X20
EI 60	SPINA2025	65	90	96	18	60			20X25

TYPE	REF.	a	b	c	d	e	f	g	Rocchetto
EI 40	SPINA 13	55	72	84	18	46	50	20	13x13-13x15
EI 48	SPINA 1616/2	55	72	84	18	46	50	20	16x16
EI 48	SPINA 1620/2	55	72	84	18	50	50	20	16x20
EI 48	SPINA 1625/2	55	72	84	18	55	50	20	16x25
EI 48	SPINA 16E	56,3	83	84	18	48,5	65,86	17	16x16

**Non prendere mai decisioni basate sulla paura.
 Prendi decisioni basate su speranze e possibilità.
 Prendi decisioni in base a ciò che dovrebbe accadere,
 non a ciò che non dovrebbe.**

**È importante che i leader siano coerenti.
 Puoi cambiare idea, ma cambiare idea in un contesto coerente.**

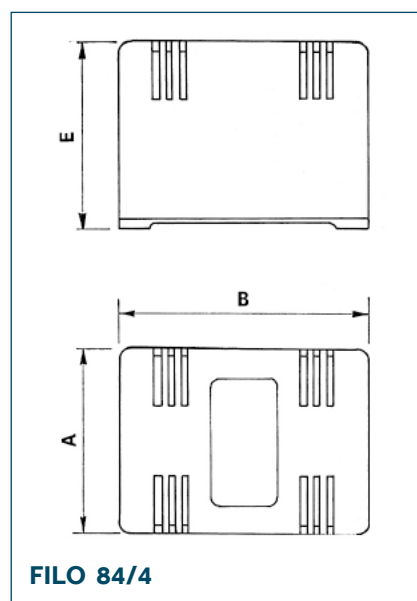
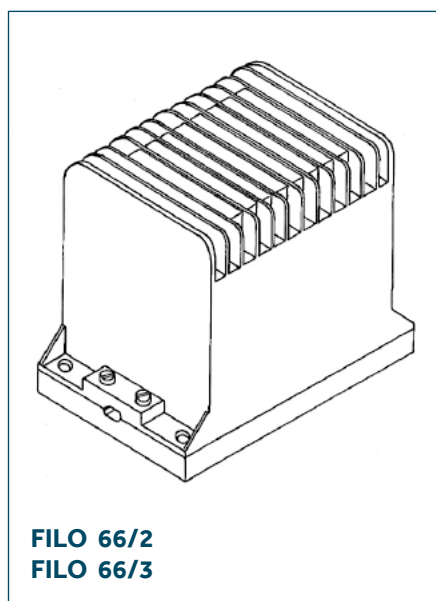
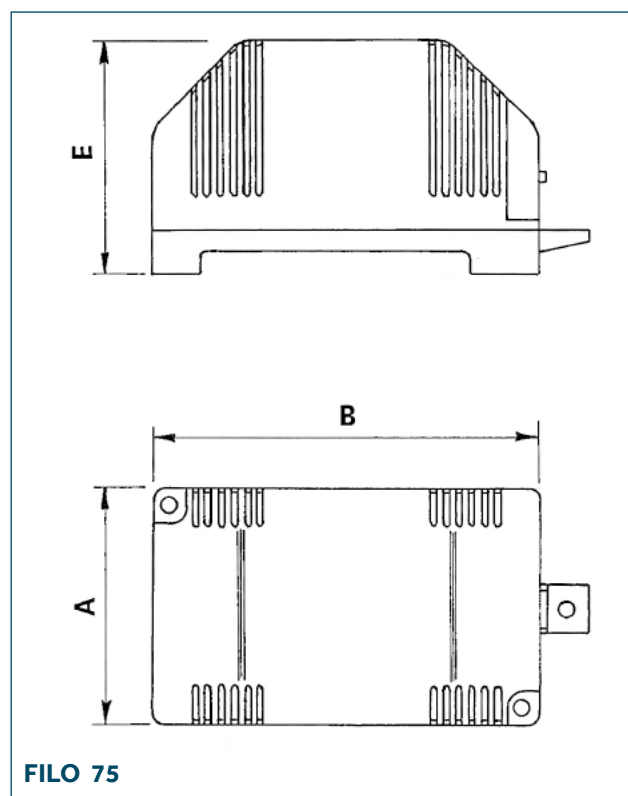
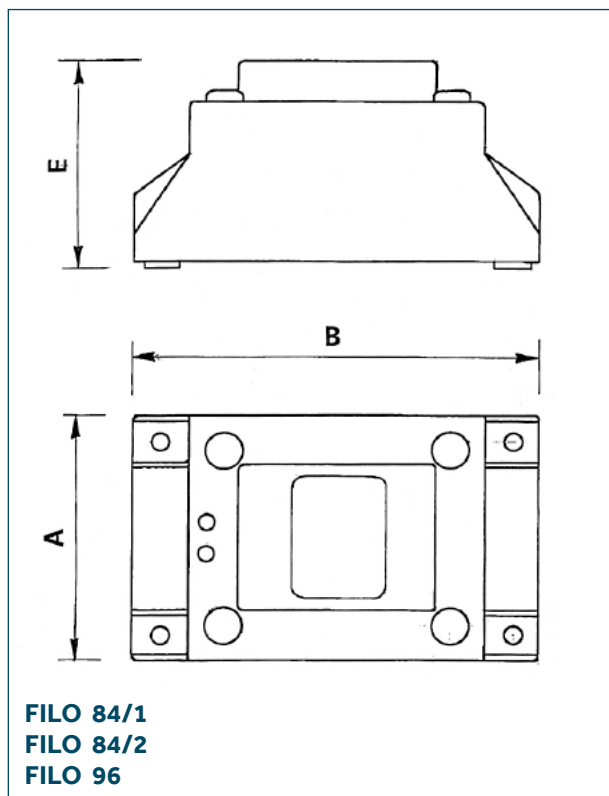

TYPE	REF.	a	b	e	foro entrata	foro uscita
EI 66	FILO 66/2	60	89,0	68,0	6,0X3,6	6,0X3,6
EI 66	FILO 66/3	71	93,0	72,0	7,0X3,6	7,0X3,6
EI 75	FILO 75	74	120,0	71,0	8,0X9,0	7,0X3,6
EI 84	FILO 84/1	80	131,5	67,5	6,2X3,8	19,5X10,0
EI 84	FILO 84/2	80	126,0	75,0	7,8X4,6	7,8X16,8
EI 84	FILO 84/4	80	110,0	75,0	7,0X5,5	7,0X5,5
EI 96	FILO 96	94	151,5	99,0	11,0X17,0	11,0X14,0

NOTA: Filo 84/1-2, Filo 96 possono essere utilizzati anche per resinare i trasformatori

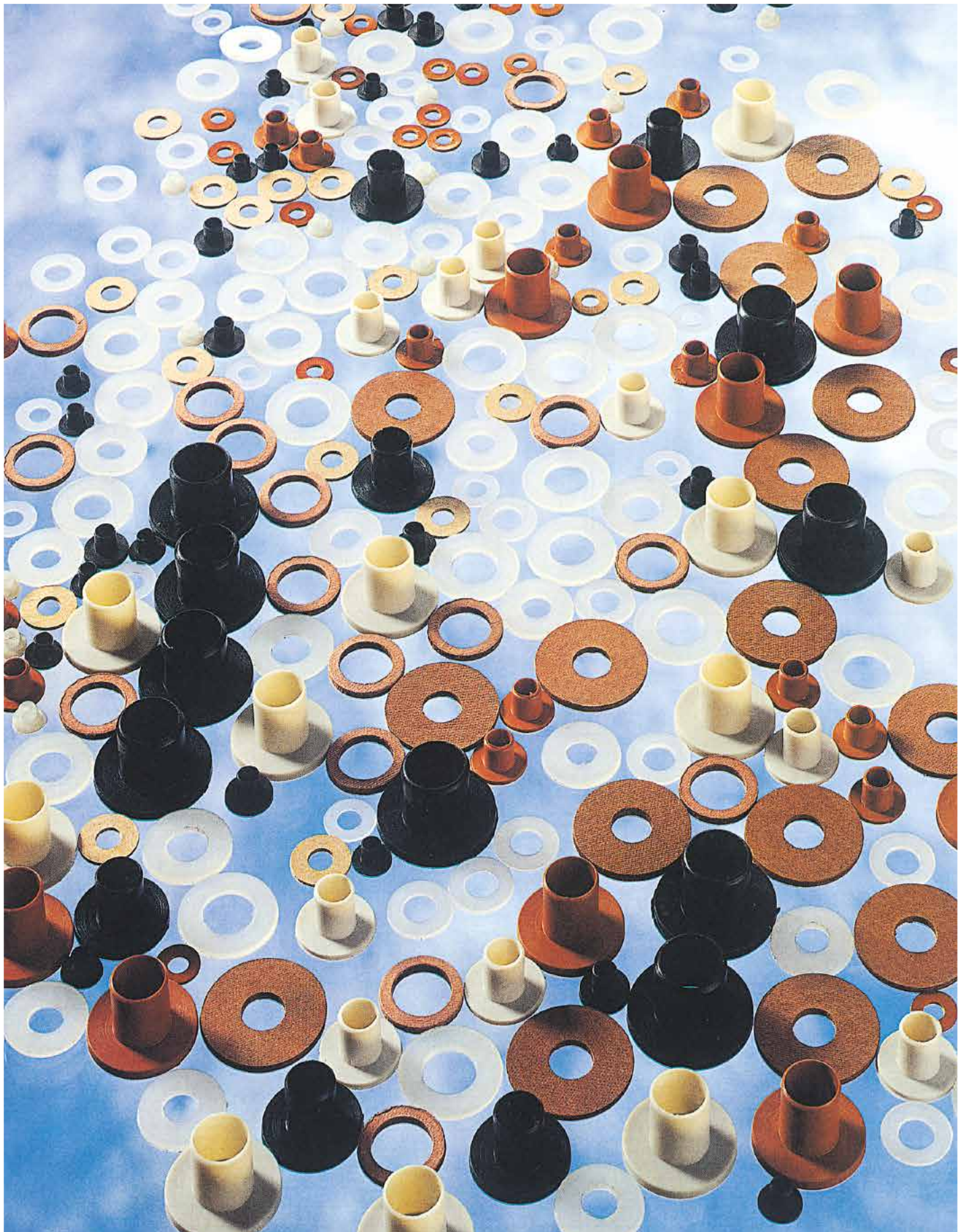

ISOLIERBUCHSEN
BUSHINGS-WASHERS
BUSSOLES-RONDELLES
BUSSOLE - RONDELLE

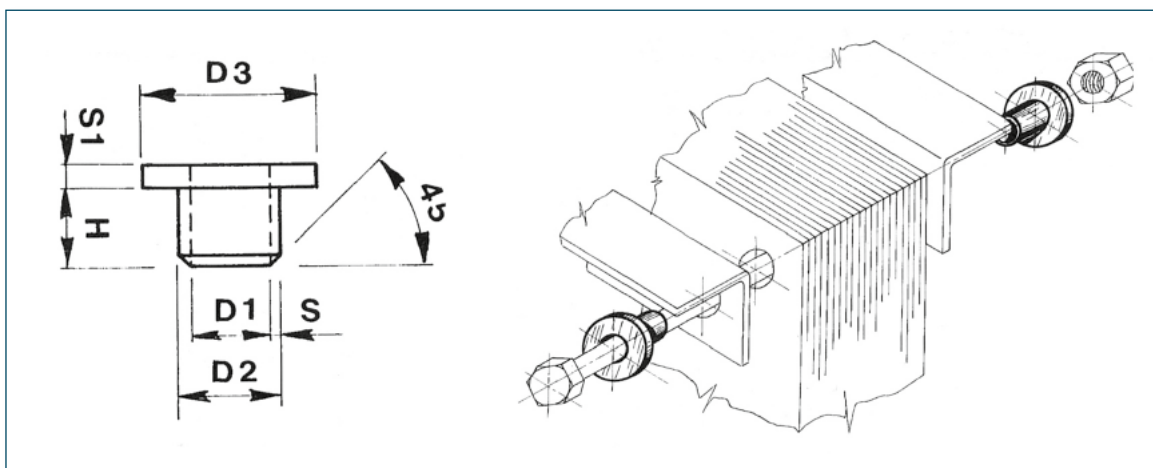

REF.	D1		D2		D3	S	S1	H
BUSS 3	3,5		4,3		9	0,4	1	5
BUSS 4	4		4,9		10	0,45	1,2	5
BUSS 5	5		5,9		12	0,45	1,5	6
BUSS 6	6	-0 +0,1	7,6	-0,2 +0,1	14	0,8	1,5	7
BUSS 8	8		9,6		19	0,8	2	11
BUSS 10	10		11,5		23	0,8	2	13
BUSS 12	12		13,6		26	0,8	2,5	15
BUSS 14	14,5	-0	16,9	-0	80	1,2	2,5	15
BUSS 16	16,5	+0,2	18,9	+0,5	32	1,2	3	18

NOTE: Solo in confezioni standard
 Rigidità dielettrica: 16kv/mm.
 Dielectric Strength: 16KV/mm.

RONDELLE IN PRESSPAN (90°C) O NYLON (120°C)

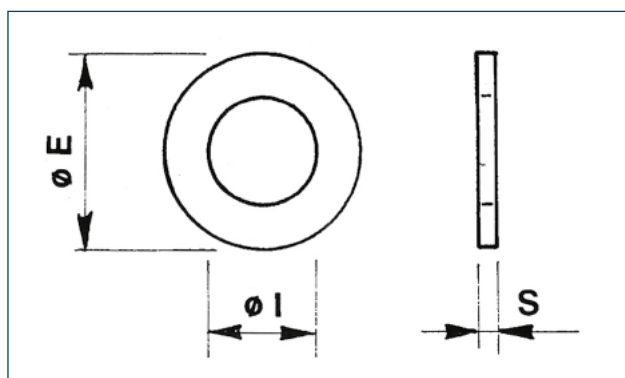

Oltre ai tipi standard abbiamo a disposizione circa 300 tipi da $\varnothing 2$ a $\varnothing 30$.

Besides the standard type, about 300 types from $\varnothing 2$ to $\varnothing 30$ are available

REF.	ØI	ØE	S
RON 3/8-1	3	8	1
RON 4/9-1	4	9	1
RON 4/10-1	4	10	1
RON 5/11-1	5	11	1
RON 5/15-1	5	15	1
RON 6/13-1	6	13	1
RON 6/15-1	6	15	1
RON 8/18-1	8	18	1
RON 8/20-1,5	8	20	1,5
RON 8/24-1,5	8	24	1,5
RON 10/22-1,5	10	22	1,5
RON 10/24-1,5	10	24	1,5
RON 12/24-1,5	12	24	1,5

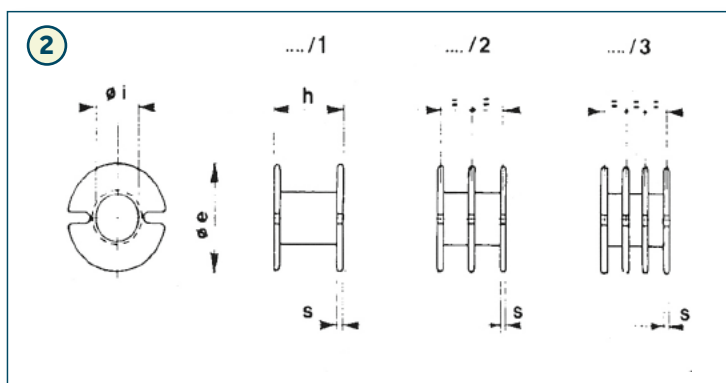
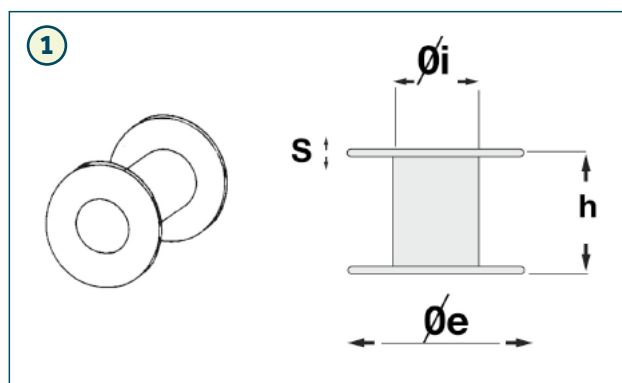

REF.	Ø I	h	Ø e	S	disegno
CM 17	4,2	17	8	1,0	1
CR 21	4,2	17,4	13,3	1,0	1
CM 21	5,5	21	10,0	0,5	1
CM 14	6,0	19,0	20,0	1,5	1
CB 14X8/1-2	6,1	5,4	11,5	0,5	B PER FERRITI 14X8 IEC
CL 7	7,0	22	24	1,5	1
CB 18X11/1-2-3	7,7	7,0	14,8	0,5	B PER FERRITI 18X11 IEC
CM 14/1	8,0	18,5	19	1,0	1
CR 7	8,0	24,5	21	1,0	1
CB 22X13/1-2-3	9,5	9,0	17,8	0,5	B PER FERRITI 22X13 IEC
CM 27	9,5	10,0	24,5	1,0	1
CR 1	10,0	19,0	Ø40,0	1,2	1
CR 2	10,0	19,0	Ø60,0	1,2	1
CB 26X16/1-2	11,7	10,8	20,9	0,6	B PER FERRITI 26X16 IEC
CL 13	13,0	31,0	31,0	1,0	1
CR 24A	13,0	30,0	31,0	1,0	
CM 26	13,5	16,0	32,5	1,0	1
CM 26/1	13,5	16,0	37,0	1,0	1
CR 25A	13,0	14,8	31	1,0	
CB 30X19/1	13,7	12,8	24,7	0,7	B PER FERRITI 30X19 IEC
CR 5	16,5	19,0	Ø40,0	1,0	1
CB 36X22/1	16,5	14,4	29,6	0,8	B PER FERRITI 36X22 IEC
CR 3	18,0	14,0	Ø65,0	1,2	1
CR 4	18,0	14,0	Ø75,0	1,2	1
CR 18	20,3	39,0	Ø44,5	2,8	1
CR 15	20,5	29,0	35,0	1,5	A con contenit. SO 35X35
CR 16	20,5	28,7	50,0	1,5	A con contenit. SO 50X50
CR 11	26,0	60,0	Ø60,0	1,5	1
CR 17	26,5	27,0	Ø47,6	0,7	1
CM 32	27,0	17,3	Ø50,0	1,5	1
CR 14	28,0	22,4	Ø51,0	1,5	1
CM 28	30,0	22,5	Ø56,5	1,5	1
CR 20	32,0	53,0	Ø54,0	2,8	1
CR 12	42,0	81,5	Ø90,0	1,5	1
CR 22	45,0	75,0	Ø80,0	1,7	1
CR 13	48,0	100,0	Ø90,0	1,6	1



**BEFESTIGINGS-WINKEL
CADRES-CORNIERS-ETRIERS
FRAMES-ANGLE-BRAKETS
TELAI - ANGOLARI - STAFFE**

TELAI PORTAMORSETTO PER TRASFORMATORI MONOFASE

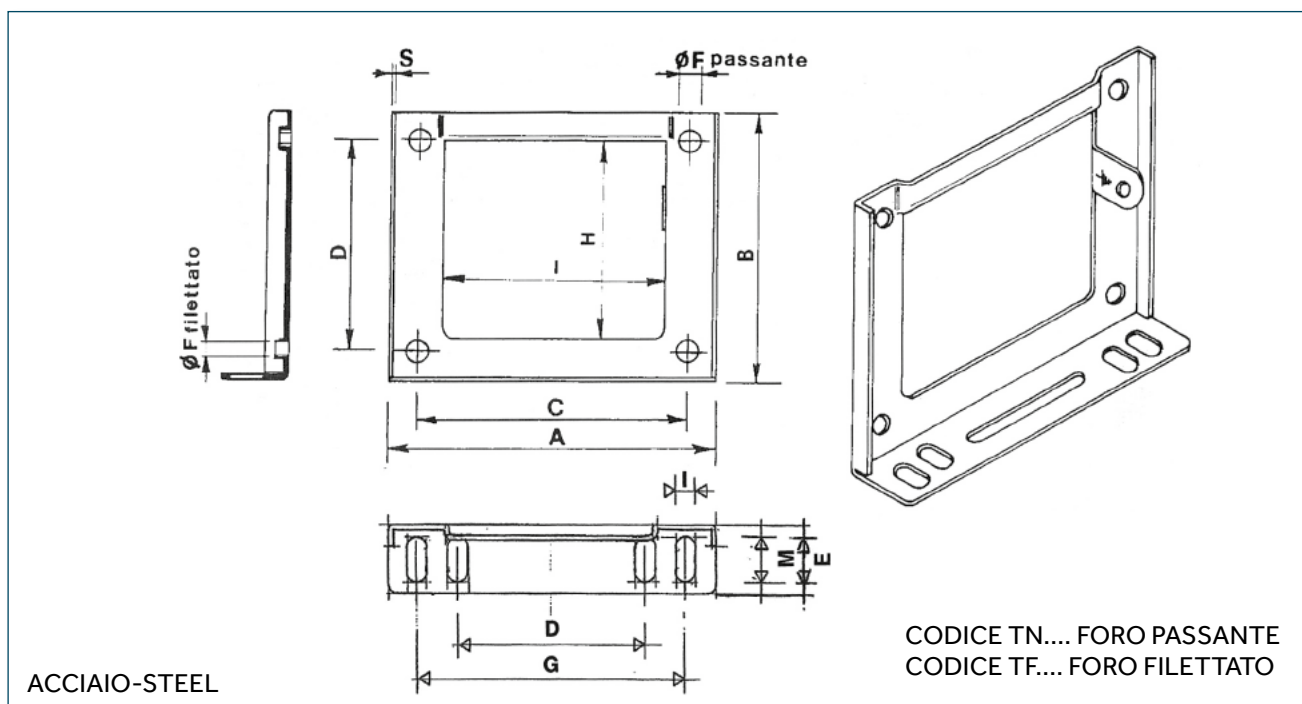

TYPE	REF.	A	B	C	D	E	Ø TN PASS.	Ø TF FILET.	G	H	I	L	M	S
EI 75	TN 25 GS-FE	76	66	62,5	50	16	4	3,5MA	62,5	48	53	4	10	1,0
EI 84	TN 28 GS-FE	85	78	70	56	18	5	4MA	70	55	57	5	10	1,0
EI 96	TN 32 GS-FE	98	82	80	64	18	5	4MA	80	60	67	6	12	1,2
EI 108	TN 36 GS-FE	110	92	90	75	22	6		90	70	75	6	12	1,5
EI 120	TN 40 GS-FE	122	102	100	80	24	6	4MA	100	76	83	6	14	1,5
EI 150	TN 50 GS-FE	153	126	125	100	26	8	5MA	125	97	103	6	18	1,5

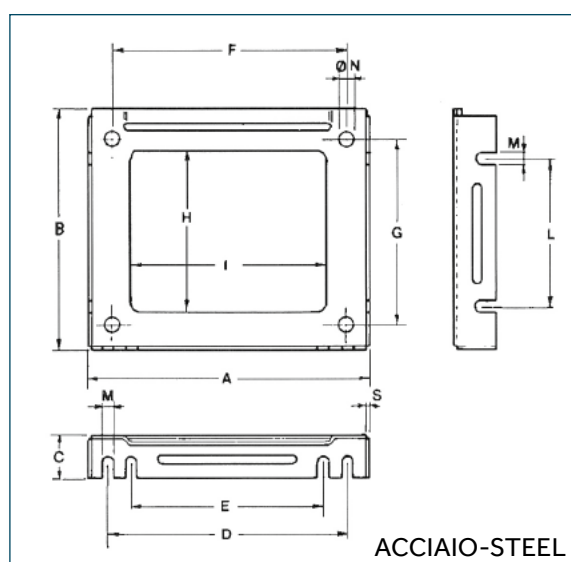

TYPE	REF.	A	B	C	D	E	F	G	H	I	L	M	Ø N	S
EI 180*	TN 60 GS-FE	184	153	25		130	150	120	105	123	96	8	9	2
EI 192*	TN 64 GS-FE	192	166	27	167	132	160	128	110	135	100	8	10	2

* DISPONIBILE CON QUOTA D=115

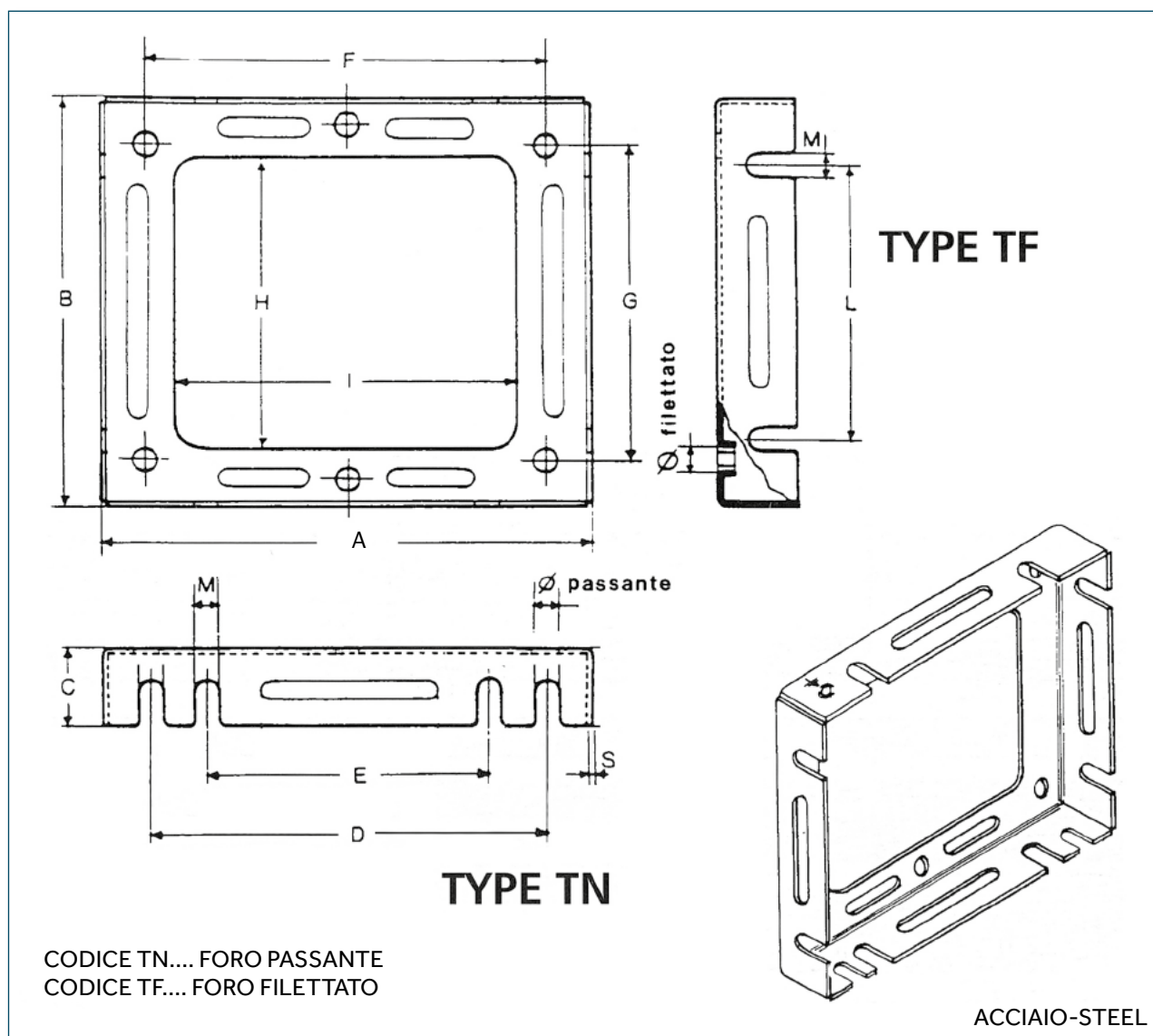

TYPE	REF.	A	B	C	D	E	F	G	H	I	L	M	ØFILET. TF	ØPASS. TN	S
50X60	TN 20-FE	62	52	13		33	50	40	42	42	35	4	3MA	4,2	0,8
58X68	TN 22-FE	71	61	12,5		50	57	46	44,5	51	43	4,2	4MA	5,2	0,85
62,5X75	TN 25-FE	77	64	14		45	62,5	50	49,5	54	44	5,1	4MA	5,2	1,0
70X84	TN 28-FE	87	75,5	15,5	70	56	70	56	53,5	62	43	6	4MA	5,2	1,2
80X96	TN 32-FE	99	83	18	80	57	80	64	59	72,5	57	6	4MA	5,2	1,2
90X108	TN 36-FE	103	94	20		41	90	72	70	77	60	6		6,2	1,2
100X120	TN 40-FE	124	104	21	100	70	100	84	74,5	86	70	6	5MA	6,2	1,2
112,5X135	TN 45-FE	139	117	22		55	112,5	90	81,5	98,5	75	6,5		6,2	1,3
125X150	TN 50-FE	154	129	24,5	125	94	125	100	86	106	95	7,3		8	1,3
150X180*	TN 60-FE	184	154	26,5		132*	150	120	116	126	115	8,2		8	1,5
160X192*	TN 64-FE	192	168	26,5		132	160	127,5	113	136	87	8,2		10	2

* DISPONIBILE ANCHE CON QUOTA E=115

ANGOLARI IN TERMOPLASTICO / THERMOPLASTIC

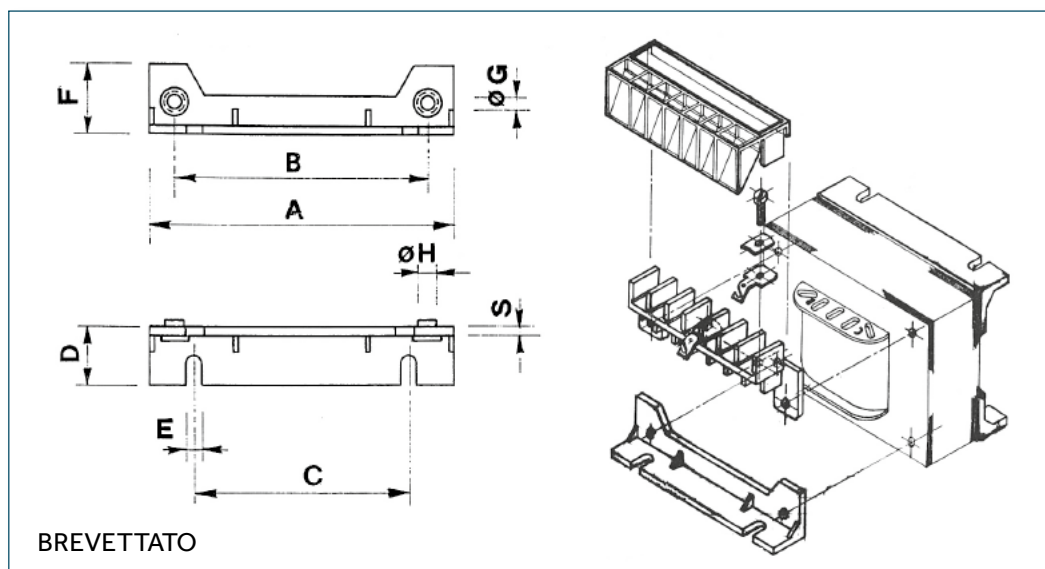

TYPE EI	REF.	A	B	C	D	E	F	G	H	S
50X60	A 20	60	50	45	11	3,5	15	3,2	3,8	2,2
55X66	A 22	66	55	50	12,5	4,2	18	3,2	4,0	2,5
62,5X75	A 25	75	62,5	55	14,5	4,2	20	3,2	4,2	2,5
65X78	A 26	85,8	70	60	18,5	10	23,2	5,3	-	3,0
70X84	A 28	84	70	60	18,5	5,2	22,5	4,2	5,8	2,5
80X96	A 32	96	80	68	18,5	5,2	22	4,2	5,8	3,0
90X108	A 36	108	90	75	20	5,6	27	4,2	5,8	3,5
100X120	A 40	120	100	80	22	6,5	29	5,2	5,8	4,0
112,5X135	A 45	135	112,5	95	23	6,2	33	6,5	7,8	4,5
125X150	A 50	150	125	105	24	7	40	6,5	7,8	5,0

SUPPORTI AD INCASTRO - DIN IN TERMOPLASTICO

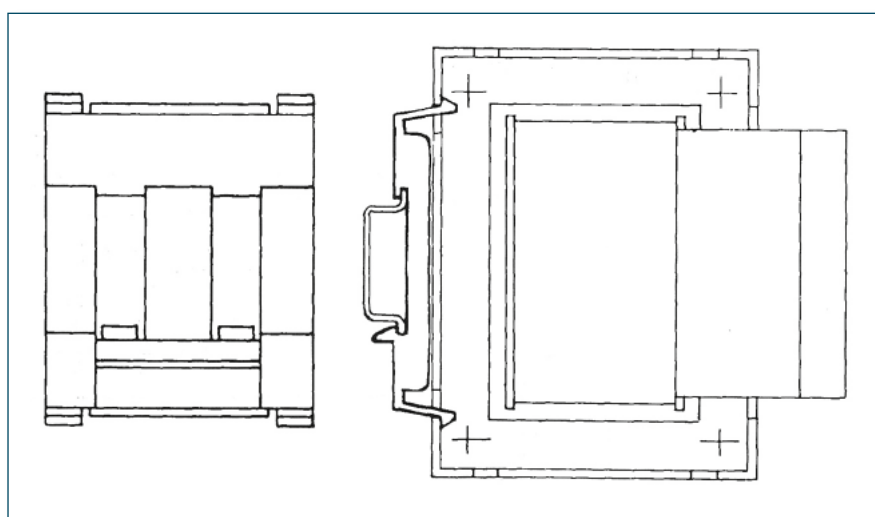

TYPE	REF.
EI/75 25X30	DIN 2530
EI/84 28X40	DIN 2840

Il nostro supporto ad incastro permette il collegamento meccanico del trasformatore all'impianto cui è destinato, in modo semplice, rapido e senza nessuna vite.

Il supporto è realizzato in un sol pezzo in materiale plastico; comprende una scanalatura longitudinale di forma rettangolare, che presenta una lunghezza circa uguale alla massima larghezza di una guida unificata a cui il supporto si accoppia. La guida unificata (guida DIN) è sostanzialmente un profilato ad "U" con alette esterne ripiegate e sporgenti.

**PATENTED
BREVETTATO**

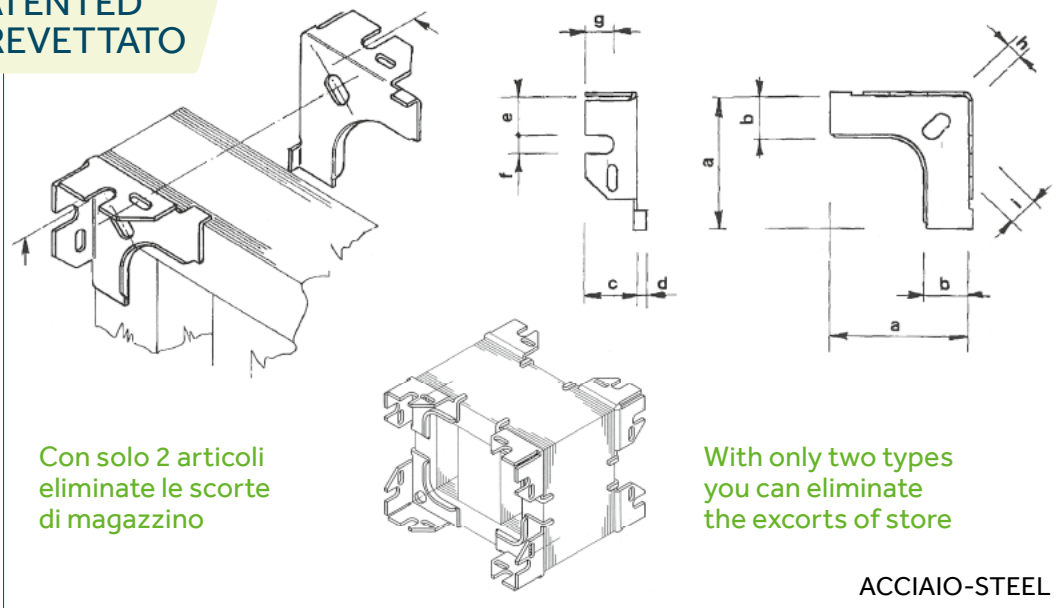

ACCIAIO-STEEL

REF.	a	b	c	d	e	f	g	h	i	L±1	M±1	per lamierini UNEL	per lamierini non unificati
ANG1-FE	31	11	16,5	5	9	5	7	5	7,5	40,5 48 58 68	53 62 74 86	62,5X75 70X84 80X96 90X108	utili soprattutto dove non esiste telaio
ANG2-FE	50	17	19	5	15	6,5	10	6,5	12	64 76,5 89 114 124	84 99 114 144 156	100X120 105X126 112,5X135 125X150 150X180 160X192	and for lamination not standard interesting solution

SQUADRETTA A Z PER SALDATURA IN ACCIAIO-STEEL

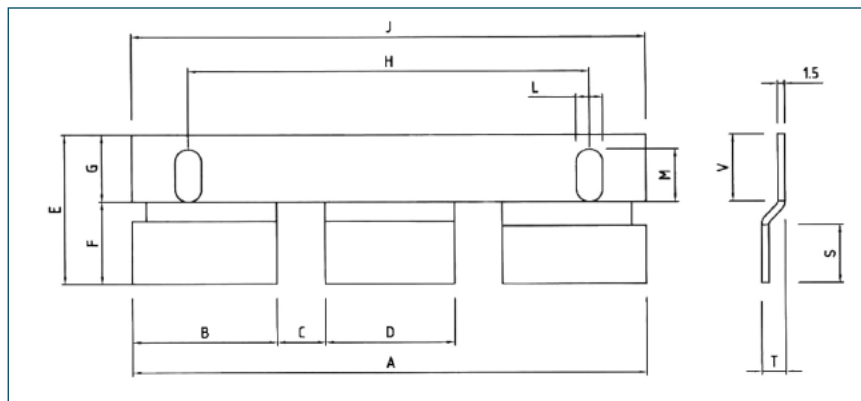

ANGOLARE	B	C	D	A	Y	X	T	F	O	DIAM	H	J	G	E
A25SAL	18	10	18	74	3	6	2,5	17	9	5	55	73,5	10	27
A28SAL	20	10	21	82	3,3	6	2,5	18,5	9	5,5	63,5	82,5	8,5	27
A32SAL	24	10	27	95	3,5	8	2,5	24,5	9	6	80	96	10,5	35
A32 SPEC.	24,5	10	19,8	95	2,5	3	2,5	12	11	6	84	92	20	32
A36SAL	30,5	10	26	107	3	3	2,7	13	11	6	84	107	19	32
A40SAL	32,5	10	33	118	2,5	8	2,8	25,5	10	5,5	90	119	13,5	40

ANGOLARI PER TRASFORMATORI MONOFASE "EI"

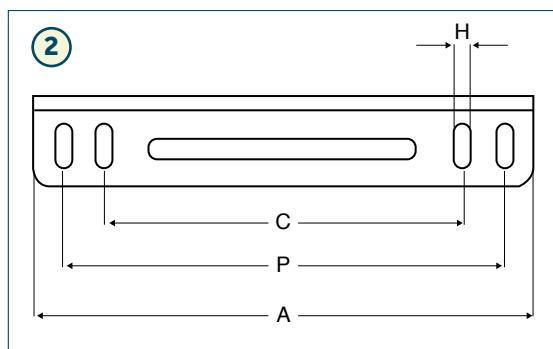
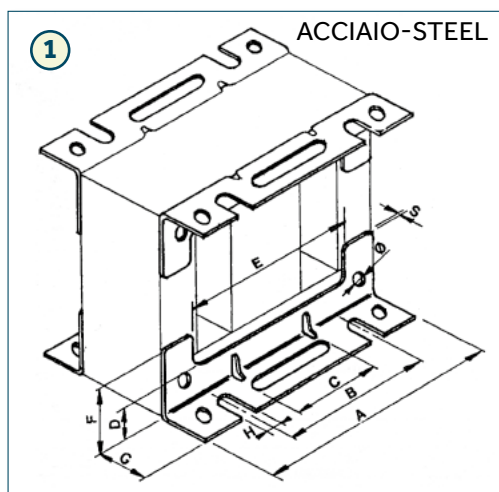

TYPE	REF.	A	B	C	D	E	F	G	H	P	S	Ø
EI 68 (1)	A22-FE	68	45		10	43	20,0	15	4,0		1,0	35,2
EI 75 (1)	A25-FE	75	53	43	8,5	51	20,0	15	4,5		1,5	4,2
EI 84 (1)	A28-FE	84	60	44	11	62	24,5	17	5,2		1,5	5,2
EI 96 (1)	A32-FE	96	68	52	12	72	25,5	18	5,2		1,5	5,2
EI 120 (1)	A40-FE	120	80	62	15	86	31,0	22	6,5		1,5	6,2
EI 150 (1)	A50-FE	150	105	2X40	18	109,5	36,0	23	6,5		1,5	6,3
EI 180 (2)	A60-FE	180	150	84	15	128	42,0	25	8,0	130*	2,0	9,3
EI 192 (2)	A64-FE	192	160		28		43,0	28	8,0	128**	2,0	10,0
EI 240 (1)	A80-FE	240	200		22		62,0	40	9,0		2,5	10,0

*A richiesta P=115 **A richiesta P=140

ANGOLARI PER TRASFORMATORI MONOFASE DIN

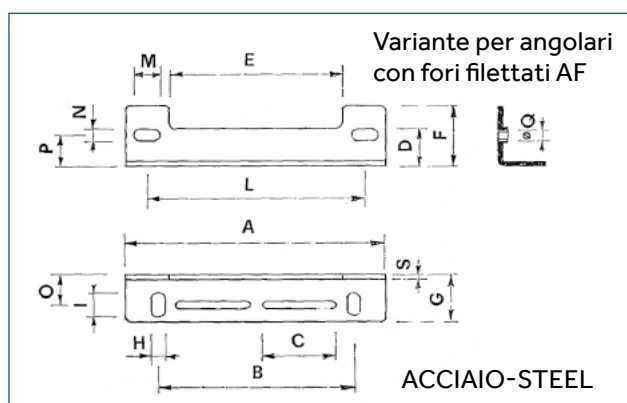

TYPE	REF.	A	B	C	D	E	F	G	H	I	L	M	N	O	P	S	ØQ
EI 55X66	A 22DIN	66	50	16	10,5	43,5	17,6	15,5	4,6	8,8	55	8,8	4,6	9,5	8,5	1,5	M3
EI 62X75	A 25DIN	75	56	20	12,5	46,0	20,0	15,0	4,8	9,0	60	9,0	4,8	8,5	11,0	1,5	M4
EI 70X84	A 28DIN	84	64	24	10,5	54,0	21,0	15,0	4,8	9,0	70	9,0	4,8	8,5	11,0	1,5	M4
EI 80X96	A 32DIN	96	84	35	15,0	66,0	25,0	20,0	5,8	11,0	80	10,0	Ø5,8	12,0	14,0	2,0	M4
EI 80X108	A 36DIN	106	84	35	15,0	75,0	24,0	20,0	5,8	11,0	88,0	11,0	5,8	13,0	14,0	2,0	M4
EI 100X120	A 40DIN	120	90	35	18,0	80,0	28,0	22,0	5,8	11,0	100	11,0	Ø5,8	14,0	15,0	2,0	M5
EI 125X150	A 50DIN	150	120	44	22,0	110,0	34,0	27,0	7,0	13,0	120	15,0	8,0	17,0	19,0	2,5	M6

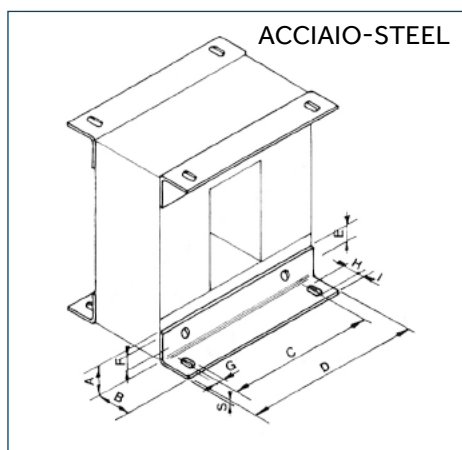

Possono essere fornite staffe con altre dimensioni di fissaggio a richiesta.

Brackets with different fixing centres available on request.

TYPE	REF.	A	B	C	D	E	F	G	H	S
200X120	ST 40 - FE	40	35	120	160	14	10,5	11	20	2
250X150	ST 50 - FE	45	45	150	200	18	10,5	11	25	2,5
300X180	ST 60 - FE	55	45	180	240	21	11,5	11	25	3
350X210	ST 70 - FE	70	50	210	280	24	11,5	11	25	3
400X240	ST 80 - FE	76	55	240	320	28	12,5	11	25	4
500X300	ST 100 - FE	80,8	60,2	300	400	28	13	11,5	30	4

STAFFE PORTAMORSETTO MONOFASE UI TIPO BASSO

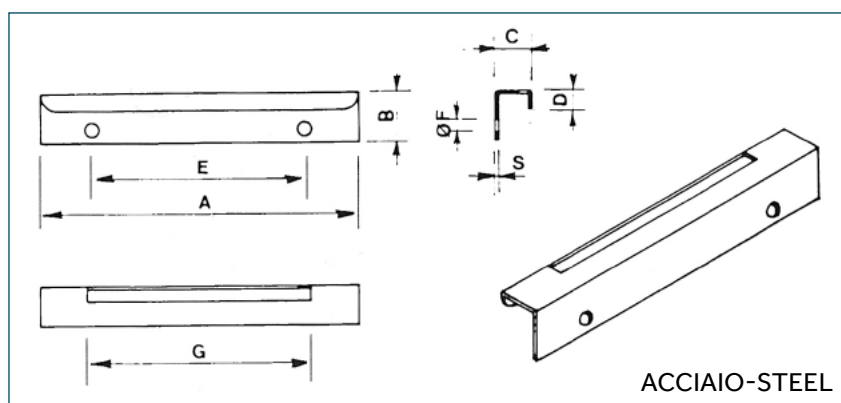

TYPE	REF.	A	B	C	D	E	ØF	G	S
200X120	ST 40/PM - FE	160	40	28	10	80	10,5	130	2
250X150	ST 50/PM - FE	200	48	28	10	100	10,5	170	2
300X180	ST 60/PM - FE	240	56	28	10	120	11,5	210	2
350X210	ST 70/PM - FE	280	60	33	10	140	11,5	250	2
400X240	ST 80/PM - FE	320	70	33	10	160	14	280	2

I sogni non diventano realtà solo perché li sogni.

È un duro lavoro che fa accadere le cose.

È un duro lavoro che crea cambiameto.

Sembra sempre impossibile, fin quando non è fatto.

STAFFE TRIFASE "UI"

BRACKETS THREE PHASE "UI" ACCIAIO-STEEL

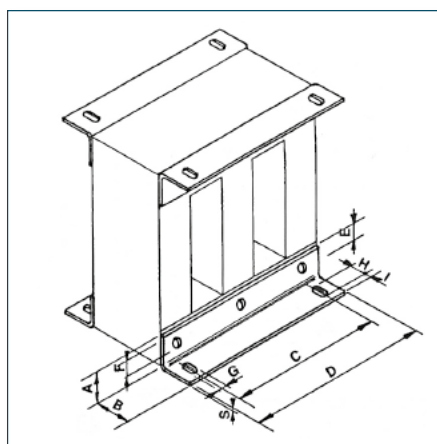

TYPE	REF.	A	B	C	D	E	F	G	H	S
100X100	A20/UI-FE	18,6	19,6	100	120	8	6,5	6,1	11	1,8
125X125	A25/UI-FE	24	22	125	150	8	6,5	7	11	1,8
150X150	A30/UI-FE	28	25	150*	180	8	8	7	14	2
200X200	A40/UI-FE	39	32	200	240	15	8	10	20	2
250X250	A50/UI-FE	45	37	250	300	15	10	10	25	2,5
300X300	A60/UI-FE	55	49	300	360	20	12	10	25	2,5
350X350	A70/UI-FE	65	47	350	420	25	12,5	10	25	3
400X400	A80/UI-FE	74	57	400***	480	30	12,5	10	25	3
500X500	A100/UI-FE	85	65	500**	600	35	15	12	30	4

*A richiesta C=145 **A richiesta C=400 ***A richiesta 375/425

STAFFE PORTAMORSETTO TRIFASE TIPO BASSO "UI" ACCIAIO-STEEL

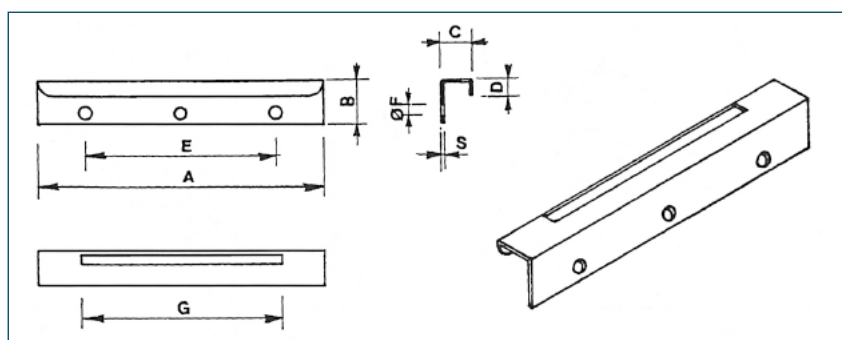

TYPE	REF.	A	B	C	D	E	ØF	G	H	S
100X100	B 20/UI-FE	120	31,2	15	10	80	6,5	100	11	1,8
125X125	B 25/UI-FE	150	26	18	10	100	7	135	11	1,8
150X150	B 30/UI-FE	180	26	19	10	120	8	160	14	2
200X200	B 40/UI-FE	240	40	24	10	160	8	220	20	2
250X250	B 50/UI-FE	300	46	24	10	200	10	275	25	2,5
300X300	B 60/UI-FE	360	57	28	10	240	12	335	25	2,5
350X350	B 70/UI-FE	420	67	29	10	280	12	400	25	3
400X400	B 80/UI-FE	460	70	30	10	320	12	450	25	3

Barretta trifase UI 150

Fissaggio con solo due viti senza dadi

**PATENTED
BREVETTATO**

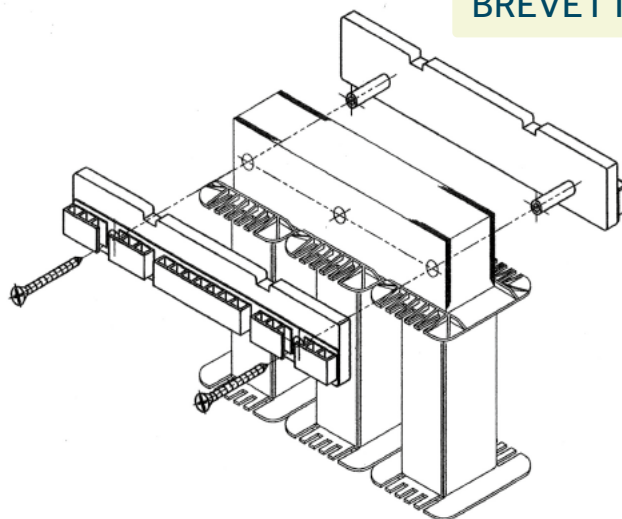
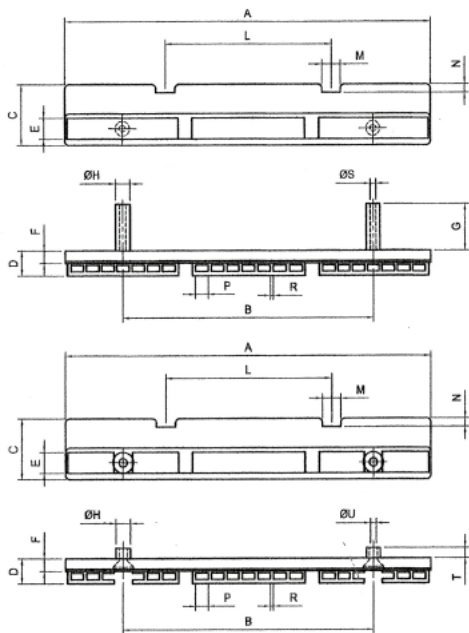

TYPE	REF	A	B	C	D	E	F	G	ØH	L	M	N	P	S	U
UI 150	B30/UI	130	120	29	12	10	5,15	22	7,16		9,45		7	3,4	4,4

→ NOTIZIA IMPORTANTE

I nostri rocchetti sono stati omologati dai nostri clienti per:

- Ferrovie Italiane
- Leonardo
- Fincantieri

Sul sito università di Bologna (trasformatore) troverete le foto dei nostri rocchetti trifase.



Se spingi attraverso quella sensazione di paura, quella sensazione di correre rischi, possono accadere cose davvero sorprendenti.

Se non corri dei rischi non crescerai.

Il fallimento è un trampolino di lancio verso il successo.

**CALOTTA IN ACCIAIO PER TRASFORMATORI
STEEL CAPS FOR SINGLE PHASE TRANSFORMERS
TAHLKAPPEN FÜR EINPHASIGE TRANSFORMATOREN**

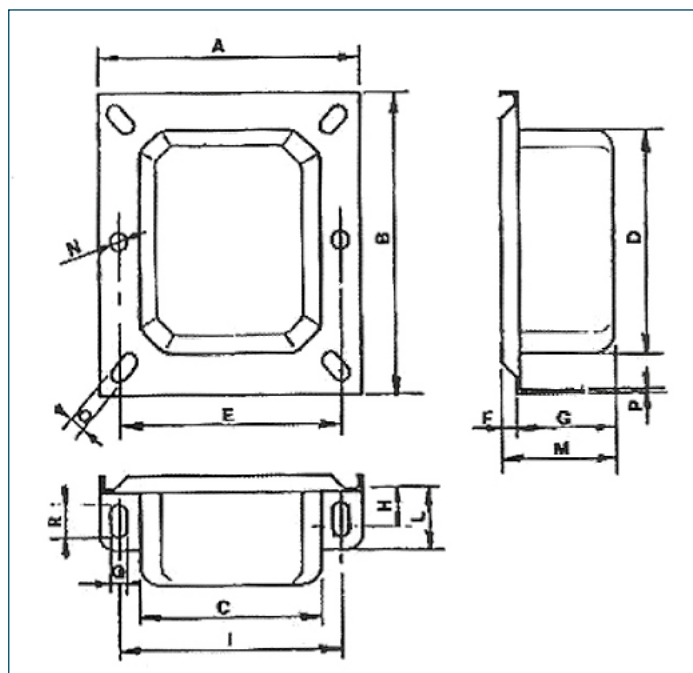

TYPE	REF.	A	B	C	D	E	F	G	H	I	L	M	N	O	P	Q	R	VER.
CAL 22	55X66	55	66	39	49	49		23		41			5,0	5,0	0,8	3,6	7,0	vert
CAL 22	58X68	59	68,5	42	52	53		24		49,5			4,0	4,0	0,8	3,8	7,0	vert
CAL 25	62,5X75	65	77	47	57	57	4	26	9	57	16	20	4,2	4,2	0,8	5	8,0	vert
CAL 28	70X84	74	78	54,5	65	64	5,5	31	7,5	60	16	36	5,0	4,5	0,8	4,5	7,5	vert
CAL 32	80X96	83	100	56	73	71	5,5	33	10,5	66	20	38,5	5,2	5,0	0,8	5,5	10,5	vert/orizz
CAL 36	90X108	93	110	66	81		6	37	13	73	22	43		5,5	0,9	5,5	8,0	vert
CAL 40	100X120	103	124	75	90		6	39	11	81	22	45		6,0	1,0	6,5	10	vert
CAL 45	112,5X135	115	139	87	96		5	40	11	92	23,5	45		6,5	1,0	7,0	10	vert
CAL 50	125X150	128	154	91	112		7	45	13	101	25	52		6,5	1,1	8,0	11	vert
CAL 60	150X180	156	183	152	121		6,5	54	18	158,5	32,5	60,5		7,0	1,2	8,0	12	vert
CAL 64	160X192	164	197	119	151		7	59	14	128,5	32	66		11	1,2	9,5	12	vert

Qualità significa fare le cose bene quando nessuno ti sta guardando.

**Per gestire te stesso, usa la testa;
per gestire gli altri, usa il tuo cuore**

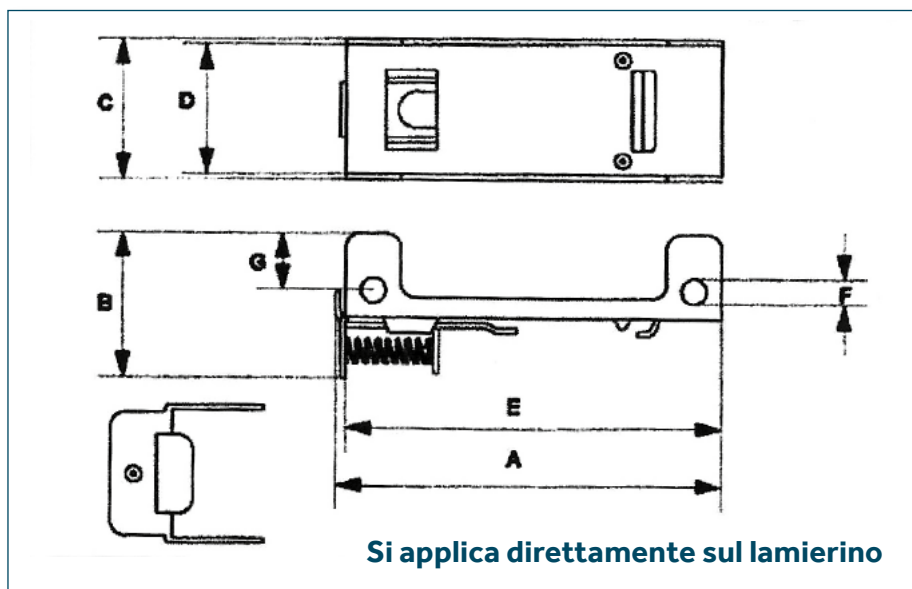

PATENTED
BREVETTATO



SUPPORTO GUIDA DIN
IN ACCIAIO STEEL

TYPE	a	b	c	d	e	f	g
DIN 25X25	72	30	29	27	70	5	11,5
DIN 25X30	72	30	34	32	70	5	11,5
DIN 25X35	72	30	39	37	70	5	11,5
DIN 25X40	72	30	44	42	70	5	11,5
DIN 28X30	86	32	34	32	84	5	12,5
DIN 28X35	86	32	39	37	84	5	12,5
DIN 28X40	86	32	44	42	84	5	12,5
DIN 28X45	86	32	49	47	84	5	12,5
DIN 28X50	86	32	54	52	84	5	12,5
DIN 32X32	98	34	38	36	96	5	14
DIN 32X40	98	34	43	41	96	5	14
DIN 32X45	98	34	48	46	96	5	14
DIN 32X50	98	34	53	51	96	5	14
DIN 32X55	98	34	58	56	96	5	14
DIN 32X60	98	34	63	61	96	5	14

I tuoi clienti più infelici sono la tua grande fonte di apprendimento.

Nel mondo degli affari, lo specchietto retrovisore è sempre più chiaro del parabrezza.

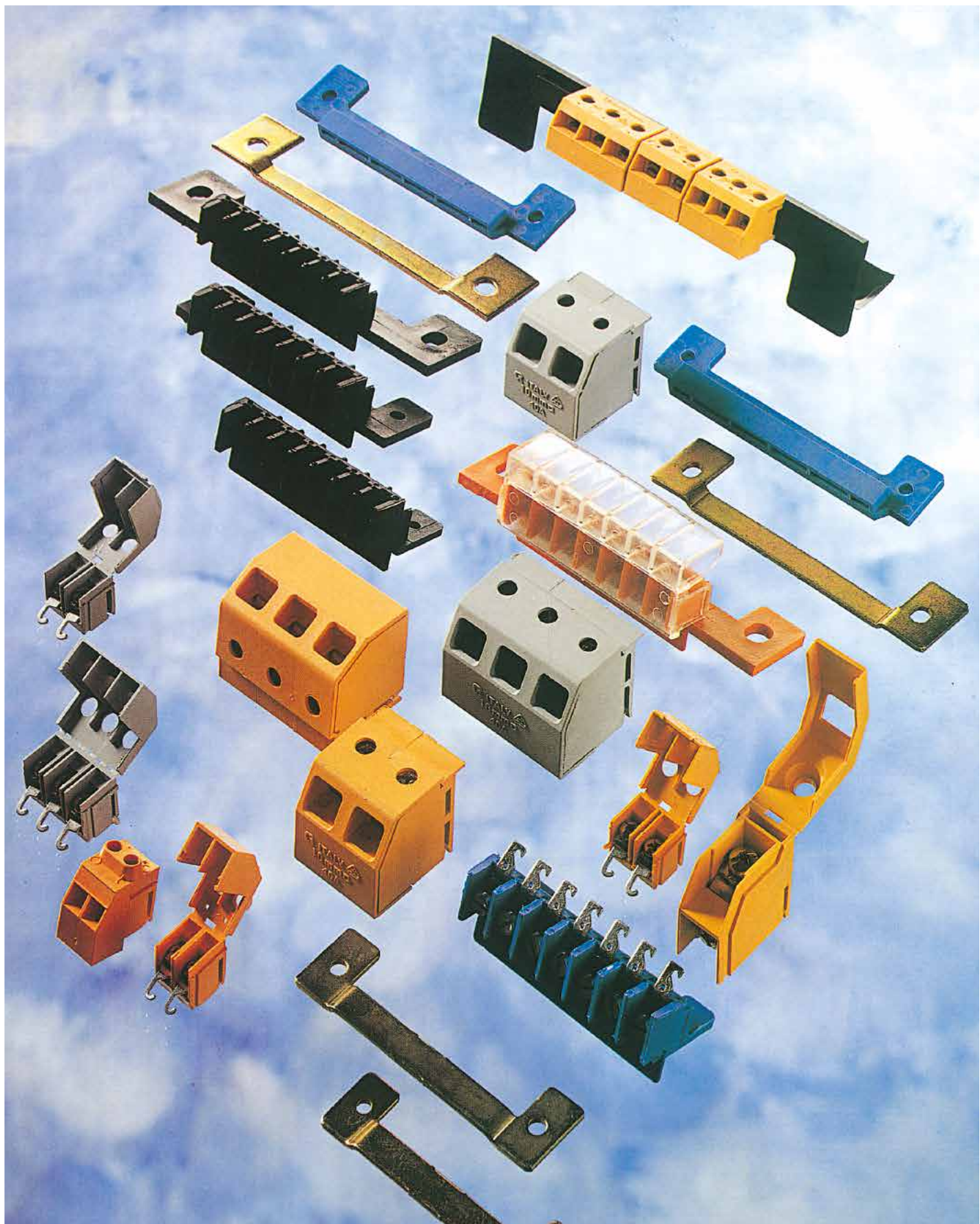

BORNES ES ACCESORIOS
TERMINAL BLOCKS AND ACCESSORIES
BORNES ET ACCESSORIES
KLEMMEN BLOCK
MORSETTI E ACCESSORI

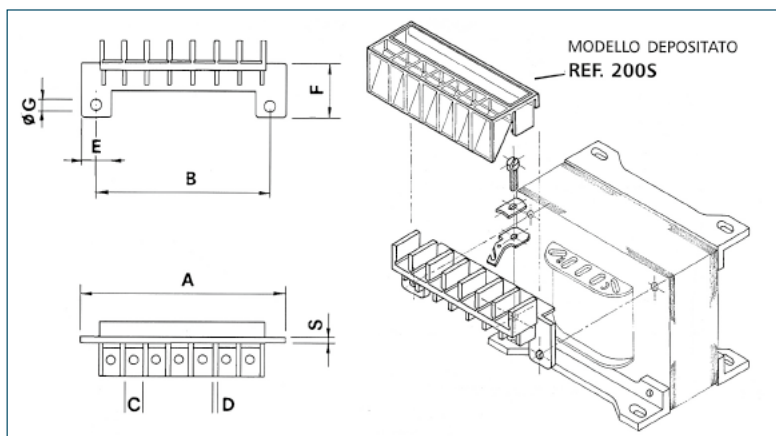

Caratteristiche

Materiale Poliammide 6 + FIBRA VETRO 30%
 Prove effettuate: 27A - 2500 Volts

Characteristics

Material: Poliamyde 6 + 30% FIBER GLASS
 Test made: 27 Amps - 2500 Volts

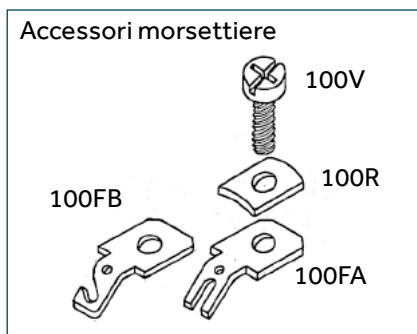
TYPE	REF.	A	B	C	D	E	F	G	S	numero term.
EI 75	M 25	74	62,5	8,5	2,2	11	25	4,5	3,0	7
EI 84	M 28	83	70,0	8,5	2,2	13	25	4,5	3,0	7
EI 96	M 32	95	80,0	8,5	2,2	14	25	4,5	3,0	7
EI 108	M 36	106	90,0	8,5	2,2	15	28	6	4,0	7
EI 120	M 40	118	100,0	8,5	2,2	17	30	6	4,0	7
EI 126	M 42	123	105,0	8,5	2,2	17	30	6	4,0	7
EI 135	M 45	133	112,5	8,5	2,2	18	30	8	4,0	7
EI 150	M 50	148	123,0	8,5	2,2	22	37	9	4,5	7

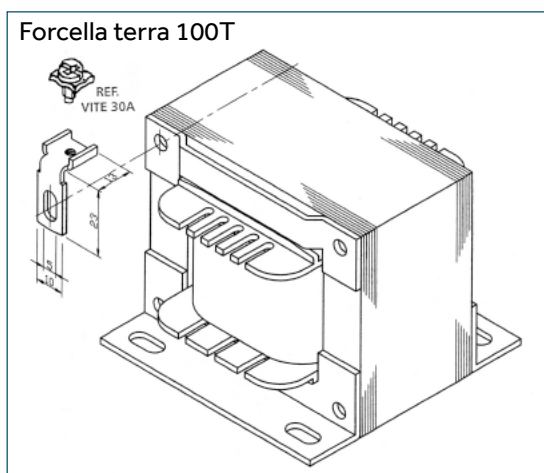

TYPE	REF.
FORCELLA A GANCIO X10A 45°	100FB/10A 45°
FORCELLA A FORCA X27A 45°	100FA/27A 45°
FORCELLA A GANCIO X16A 45° E 90°	100FB/16A - 45° - 90°
FORCELLA A GANCIO X27A 45° E 90°	100FB/27A - 45° - 90°
FORCELLA A GANCIO X30A	100FB/30A - 45°
FORCELLA VITE/VITE	100FB/63A - 90°
RANELLA PER MORSETTO	100R
VITE 4X10 PER MORSETTO	100V

TERMINALI DI TERRA / EARTH TERMINAL

TYPE	REF.
FORCELLA "TERRA" A 90° 23X13	100T - Ø 5 - Ø 6
172 FASTON MASCHI Ø 3 45°, 90°	172/3-45°, 90°
172 FASTON MASCHI Ø 4 45°, 90°	172/4-45°, 90°
172 FASTON MASCHI Ø 5 45°, 90°	172/5-45°, 90°
172 FASTON MASCHI Ø 6 45°, 90°	172/6-45°, 90°

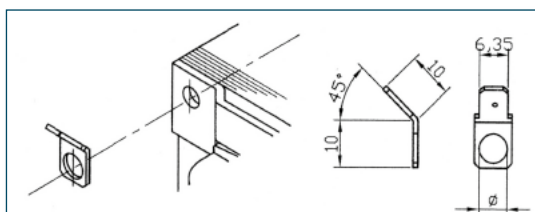

REF. 172
 FASTON MASCHI
 (Ø 3-4-5-6)

BARRE PORTAMORSETTI PER TRASFORMATORI MONOFASE KLEMMSTANGEN FÜR EINPHASIGE TRASFORMATOREN

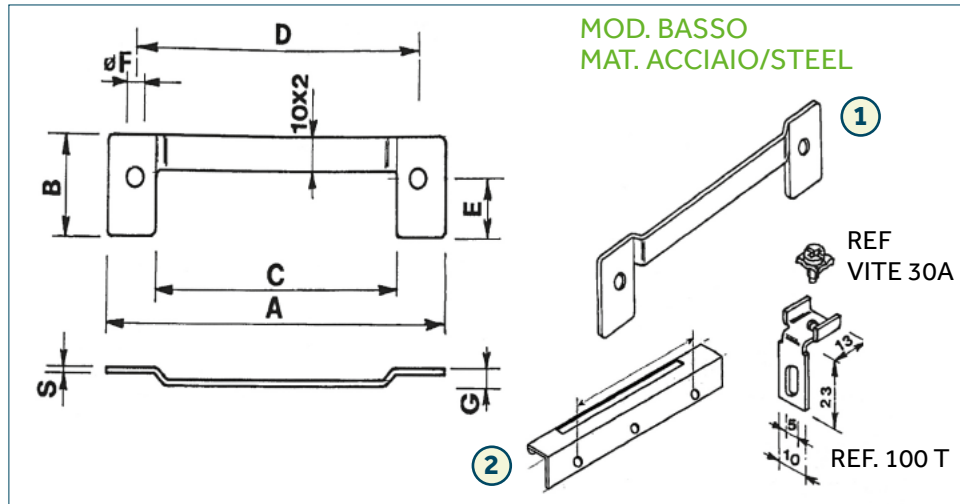

TYPE	REF.	A	B	C	D	E	ØF	G	S	disegno
EI 75	BAR25-FE	75	20	52	62,5	8	4,2	4	2	1
EI 84	BAR28-FE	84	22	60	70	10	4,2	4	2	1
EI 96	BAR32-FE	96	25	68	80	13	5,2	4	2	1
EI 120	BAR40-FE	120	28	85	100	17	5,2	4	2	1
EI 150	BAR50-FE	150	30	104	125	17	8	4	2	1
EI 180	BAR60-FE	180	35	125	150	20	8	5	2	2
EI 192	BAR64-FE	192	45	137	160	23	8	5	2	1
EI 240	BAR80-FE	240	53	172	200	28	11	6	2	2

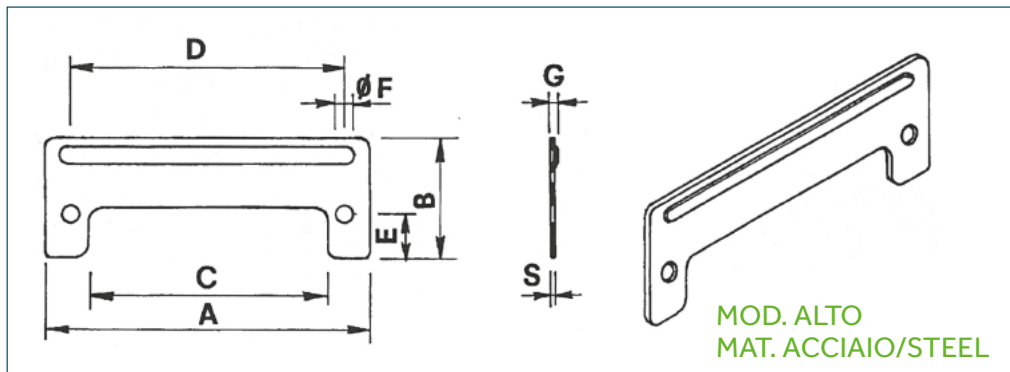

TYPE	REF.	A	B	C	D	E	ØF	G	S
EI 68	BAR22-A-FE	68	34	48	62	12,5	4,2	2	2
EI 75	BAR25-A-FE	75	30	51	62,5	10,5	4,2	2	1,5
EI 84	BAR28-A-FE	84	32	62	70	11,5	5,2	2	1,5
EI 96	BAR32-A-FE	96	35	73	80	12,5	5,5	2	1,5
EI 120	BAR40-A-FE	120	40	92	100	16,5	6,8	2	1,5
EI 150	BAR50-A-FE	150	50	108	125	20,0	6,0	2	2
EI 180	BAR60-A-FE	180	70	125	150	28,0	7,0	2	2
EI 192	BAR64-A-FE	192	70	145	160	28,0	7,0	2	2
EI 240	BAR80-A-FE	240	83	172	200	42,0	7,0	2	2

BARRETTE PORTAMORSETTI IN TERMOPLASTICO THERMOPLASTICHE / KLEMMSTAGEN

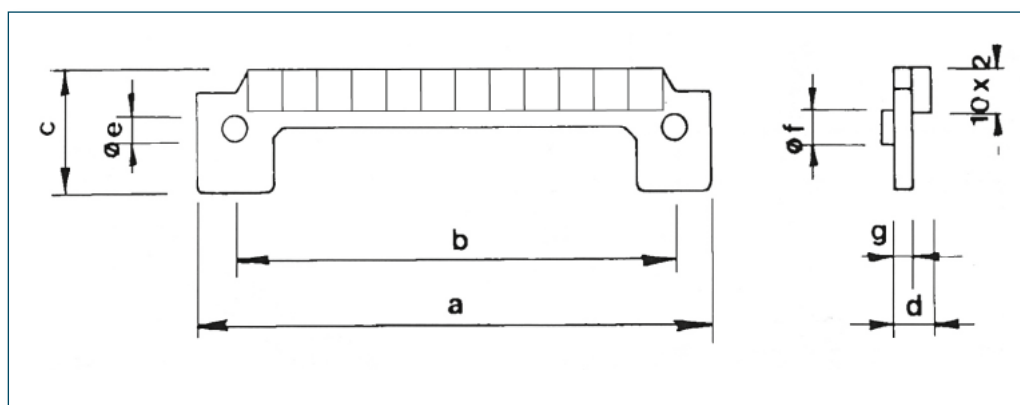

LAMIERINO	REF.	a	b	c	d	Øe	Øf	g	TIPO MATERIALE
EI 75	BAR25	74	62,5	25	8,5	4	5	3	TERMOPLASTICO
EI 84	BAR28	83	70	25	8,5	4,5	5,5	3	TERMOPLASTICO
EI 96	BAR32	95	80	25	8,5	5	6	3	TERMOPLASTICO
EI 108	BAR36	107	89,5	25	8,5	5	6	3	TERMOPLASTICO
EI 120	BAR40	117,0	100,0	28	8,5	5,2	5,8	4,0	TERMOPLASTICO
EI 126	BAR42	123,0	105,0	35	8,5	5,2	5,8	4,0	TERMOPLASTICO
EI 135	BAR45	130,5	112,5	33	9,0	6,5	7,8	4,5	TERMOPLASTICO
EI 150	BAR50	147,0	125,0	31	9,0	6,5	7,8	4,5	TERMOPLASTICO
EI 180	BAR60	175,0	150,0	39	9,0	6,5	7,8	4,5	TERMOPLASTICO
EI 192	BAR64	187,0	160,0	42	9,0	6,5	7,8	4,5	TERMOPLASTICO

MORSETTI IN TERMOPLASTICO RP9 CR 1A SERIE

TESTATI E OMOLOGATI IN CONFORMITÀ ALLE NORME:

DIN EN 60998-1 (VDE 0613 teil 1): 1994-04 EN 60998-1: 1993

DIN EN 60998-2-1 (VDE 0613 teil 2-1): 1994-04 EN 60998-2-1: 1993

Questi morsetti ricalcano il principio delle nostre morsettiere fisse, hanno 3 principali caratteristiche:

1. Sono stati progettati secondo le norme di sicurezza internazionali e di autoestinguenza (UL94-VO)
2. Permettono un enorme risparmio di denaro perché eliminando telai, angolari, riducono notevolmente l'impiego di manodopera nell'assemblaggio dei trasformatori.

These electrical clamps, following the principal of our fixed electrical clamps, have three main features:

1. They have been projected following the present international security law and are also autoextinguishing (UL94-VO).
2. They allow to save much money because eliminating frames, angular, they remarkably reduce the need for labour in assembling the transformers

TYPE CIERRE	TEMPERATURA (°C) AMBIENTE	TENSIONE DI ISOLAMENTO	SEZIONE mm ²	
			DICHIARATA	OMOLOGATA
M10	DA -5 A +70	AC 250V	1,5	1,5
M16	DA -5 A +70	AC 450V	2,5	1,5
M30	DA -5 A +70	AC 750V	4	2,5
M63	DA -5 A +70	AC 750V	10	6

MORSETTI 10A IN TERMOPLASTICO CR 1ª SERIE

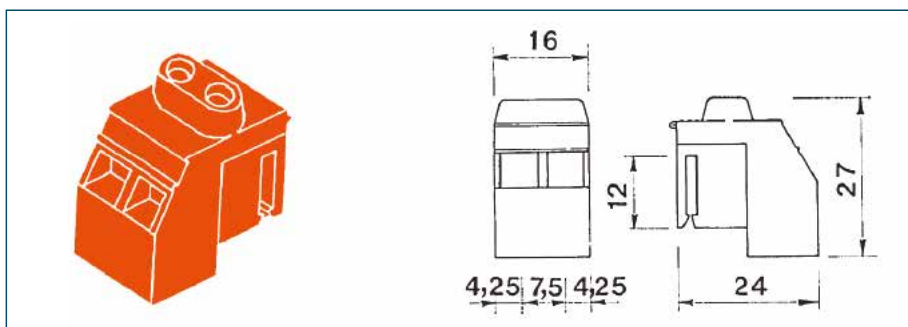

CONFEZIONE STANDARD: 500 Pz.
STANDARD - TÛTEN: 500 Pz.

WIRE RANGE 14-24
mm² 1,5

TYPE	REF.	h	NUMERO POSTI
MORSETTO 10A GRIGIO	M10A 2P G	16	2 (MORSETTO BIPOLARE)
MORSETTO 10A ARANCIO	M10A 2P AR	16	2 (MORSETTO BIPOLARE)

MORSETTI 16A IN TERMOPLASTICO CR 1ª SERIE

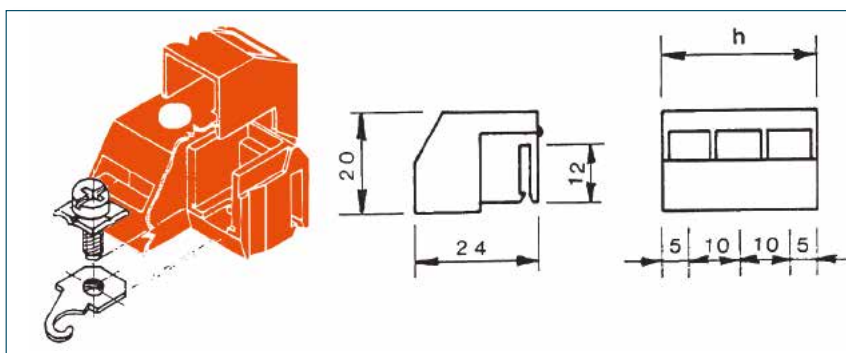

CONFEZIONE STANDARD: 200/250 Pz.
STANDARD - TÛTEN: 200/250 Pz.

WIRE RANGE 14-24
mm² 2,5

TYPE	REF.	h	NUMERO POSTI
MORSETTO 16A GRIGIO	M16A 2P G	20	2 (MORSETTO BIPOLARE)
MORSETTO 16A ARANCIO	M16A 2P AR	20	2 (MORSETTO BIPOLARE)
MORSETTO 16A GRIGIO	M16A 3P G	30	3 (MORSETTO TRIPOLARE)
MORSETTO 16A ARANCIO	M16A 3P AR	30	3 (MORSETTO TRIPOLARE)

MORSETTI 30A IN TERMOPLASTICO CR 1ª SERIE

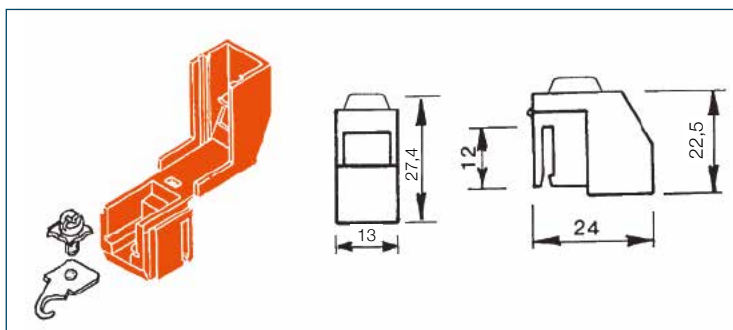

CONFEZIONE STANDARD: 500 Pz.
STANDARD - TÛTEN: 500 Pz.

WIRE RANGE 12-20
mm² 4

TYPE	REF.	h	NUMERO POSTI
MORSETTO 30A GRIGIO	M30A 1P G	13	1 (MORSETTO UNIPOLARE)
MORSETTO 30A ARANCIO	M30A 1P AR	13	1 (MORSETTO UNIPOLARE)

NOTE: morsetti vendibili solo in confezioni standard

MORSETTI 30A IN TERMOPLASTICO CR 1^A SERIE

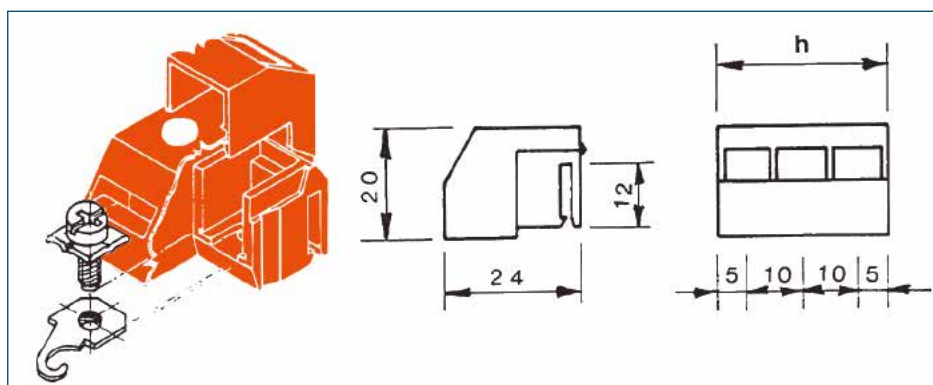

WIRE RANGE 12-20

mm² 4

TYPE	REF.	h	NUMERO POSTI
MORSETTO 30A GRIGIO	M30A 2P G	26	2 (MORSETTO BIPOLARE)
MORSETTO 30A ARANCIO	M30A 2P AR	26	2 (MORSETTO BIPOLARE)
MORSETTO 30A GRIGIO	M30A 3P G	39	3 (MORSETTO TRIPOLARE)
MORSETTO 30A ARANCIO	M30A 3P AR	39	3 (MORSETTO TRIPOLARE)

BIPOLARI - TRIPOLARI

CONFEZIONE STANDARD: 200 Pz.
STANDARD - TÛTEN: 200 Pz.

CONFEZIONE STANDARD: 150 Pz.
STANDARD - TÛTEN: 150 Pz.

MORSETTI 63A IN TERMOPLASTICO CR 1^A SERIE

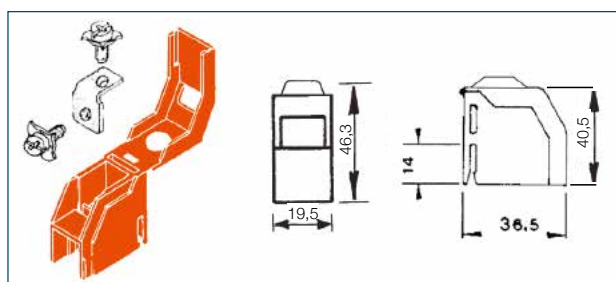

CONFEZIONE STANDARD: 150 Pz.
STANDARD - TÛTEN: 150 Pz.

WIRE RANGE 6-12

mm² 10

TYPE	REF.	h	NUMERO POSTI
MORSETTO 63A GRIGIO	M63A 1P G	18,6	1 (MORSETTO UNIPOLARE)
MORSETTO 63A ARANCIO	M63A 1P AR	18,6	1 (MORSETTO UNIPOLARE)

BIPOLARI - TRIPOLARI

Per la versione a 2 posti e a 3 posti. Il coperchio viene fornito a parte.

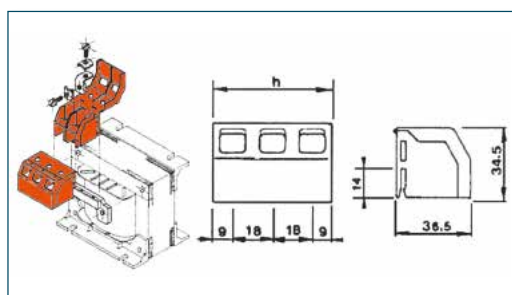

TYPE	REF.	h	NUMERO POSTI
COPERCHIO 63A GRIGIO	C63A 2PG	36	2 (COPERCHIO BIPOLARE)
COPERCHIO 63A ARANCIO	C63A 2P AR	36	2 (COPERCHIO BIPOLARE)
COPERCHIO 63A GRIGIO	C63A 3P G	54	3 (COPERCHIO TRIPOLARE)
COPERCHIO 63A ARANCIO	C63A 3P AR	54	3 (COPERCHIO TRIPOLARE)

TYPE	REF.	h	NUMERO POSTI
MORSETTO 63A GRIGIO	M63A 2P G	36	2 (MORSETTO BIPOLARE)
MORSETTO 63A ARANCIO	M63A 2P AR	36	2 (MORSETTO BIPOLARE)
MORSETTO 63A GRIGIO	M63A 3P G	54	3 (MORSETTO TRIPOLARE)
MORSETTO 63A ARANCIO	M63A 3P AR	54	3 (MORSETTO TRIPOLARE)

CONFEZIONE STANDARD: 150 Pz.
STANDARD - TÛTEN: 150 Pz.

CONFEZIONE STANDARD: 100 Pz.
STANDARD - TÛTEN: 100 Pz.

MORSETTI DA 60A A 300A IN TERMOPLASTICO CR 1^A SERIE

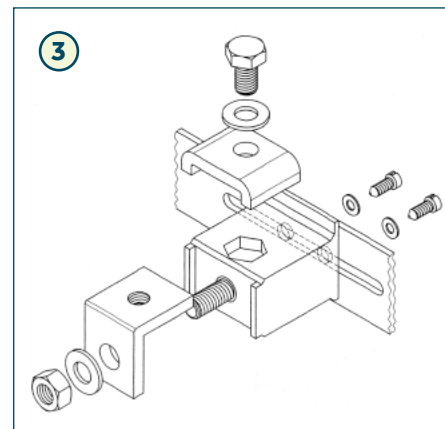
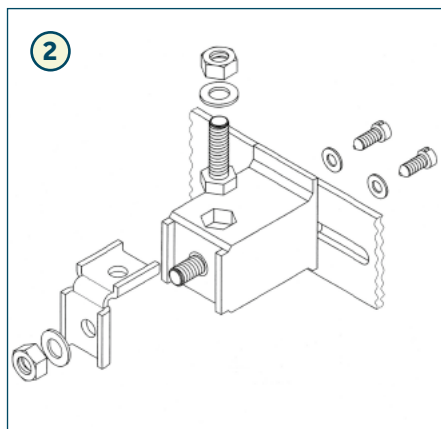
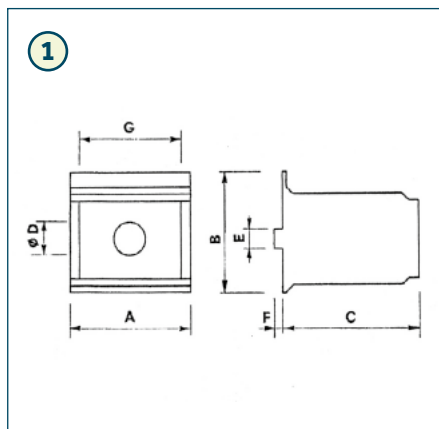

TYPE	REF.	A	B	C	D	E	F	G	disegno
M6	M6-RP6	26	34,5	38	6,5	5,5	2,5	20,5	1
M8	M8-RP6	36	34,5	38	8,5	5,5	2,5	30,5	1
M6/60	M6/60A	SOLO CON VITE 6MA + BULLONE							2
M6/150	M6/150A	CON VITE 6MA + PIASTRA + BULLONE							2
M8/100	M8/100A	SOLO CON VITE 8MA + BULLONE							3
M8/300	M8/300A	CON VITE 8MA + PIASTRA + BULLONE							3

MORSETTI TRIFASE CON PROTEZIONE CR 2^A SERIE

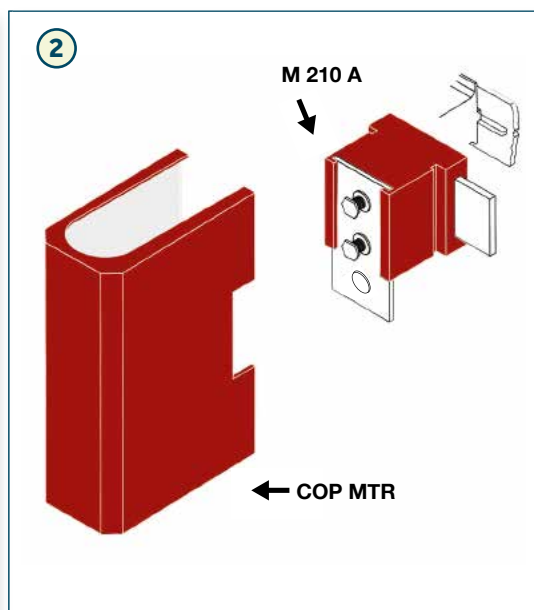
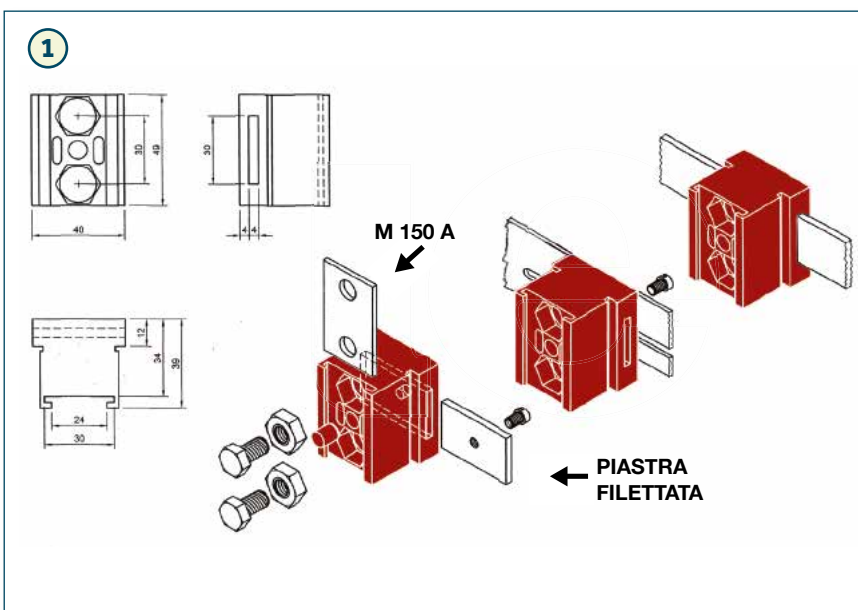

A150/A210

TYPE	REF	LAMINA	SPESSORE	DIMENSIONE	disegno
M 150 A	MORMTR 150	25 x 50	3	40 x 49 BIPOLARE	1
M 210 A	MORMTR 210	25 x 70	3	40 x 49 TRIPOLARE	2
COPERCHIO	COP MTR			40 X 110	2
PIASTRA				PIASTRA FILETTATA	

CONFEZIONI STANDARD
DI VENDITA 50 PZ.

ETICHETTE PER MORSETTI

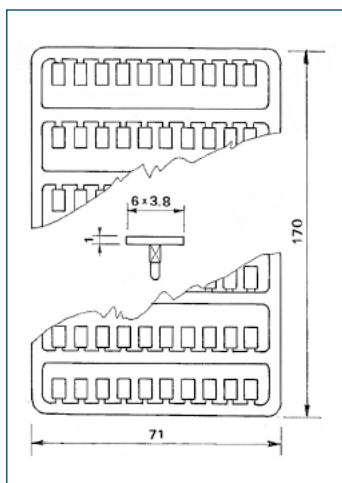

TYPE	REF.
NEUTRE	ET/MOR/NEUTRA
SERIGRAFATE	ET/MOR/....
SERIGRAFATE DISPONIBILI	0; 1; 2; 3; 4; 5; 6; 7; 8; 9; 11; 12; 16; 18; 23; 24;25,5; 26,5; 29; 31,5; 42; 45; 48; 55; 100; 110; 115; 200; 220; 230; 240; 380; 400; 415; 420; 440; 460; 480;N; IN; OUT; P1; P2; P3; S1; S2; S3; L1; L2; PRI; SEC; -2,5%; +2,5%; -5%; +5%; -10%; +10%; -15%; +15%;

NOTE: numeri a richiesta

FORCELLA A PONTE PER MORSETTI

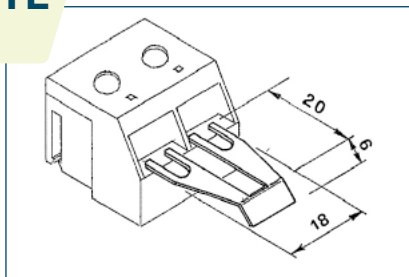

TYPE	REF.
FORCELLA A PONTE PER 30A	PONTE 30A

OMOLOGAZIONE UL N° E355624



VEDI PAGINE 86-87-88

MORSETTI E FUSE SERIE "K"

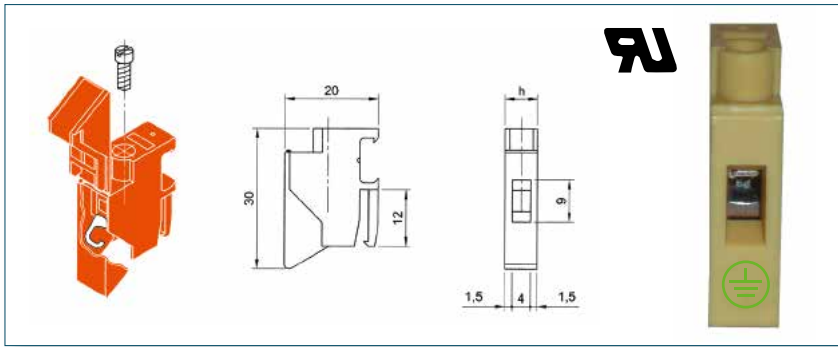

TYPE	REF
MORSETTI 16A 1 POSTO ARANCIO	K-M16A1PKAR
MORSETTI 16A 1 POSTO GRIGIO	K-M16A1PKG

WIRE RANGE 10-20
mm² 2,5

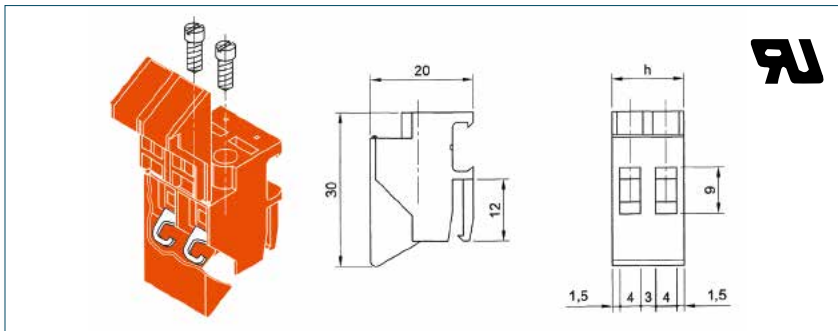

TYPE	REF
MORSETTI 16A 2 POSTI ARANCIO	K-M16A2PKAR
MORSETTI 16A 2 POSTI GRIGIO	K-M16A2PKG

WIRE RANGE 10-20
mm² 2,5

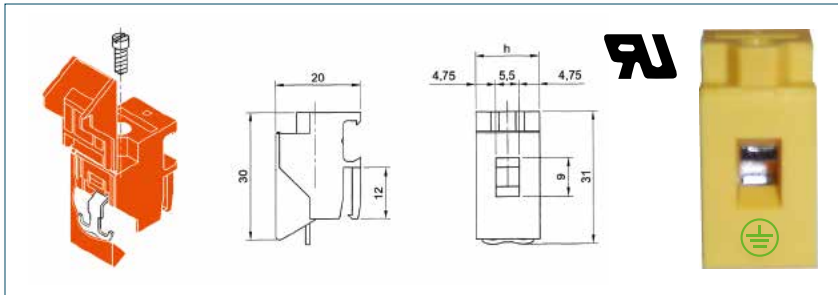

TYPE	REF
MORSETTI 30A 1 POSTO ARANCIO	K-M30A1PKAR
MORSETTI 30A 1 POSTO GRIGIO	K-M30A1PKG

WIRE RANGE 10-20
mm² 4

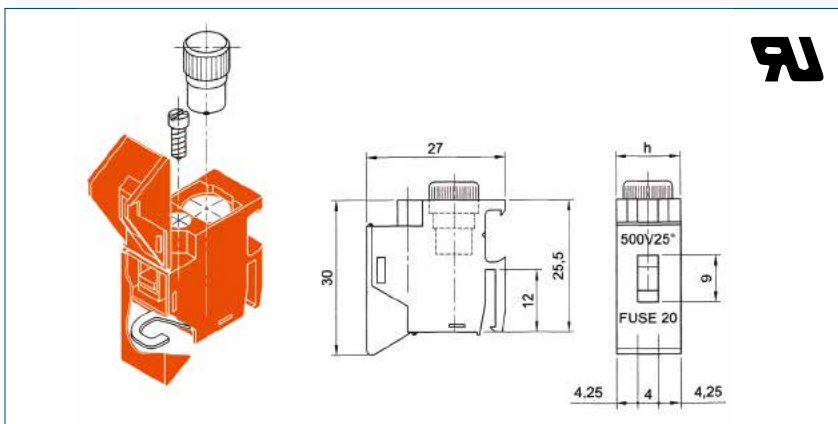

TYPE	REF
MORSETTI 16A 1P FUSE ARANCIO	K-M16A1PFUAR
MORSETTI 16A 1P FUSE GRIGIO	K-M16A1PFUG

FUSIBILE 5X20
WIRE RANGE 10-20
mm² 2,5

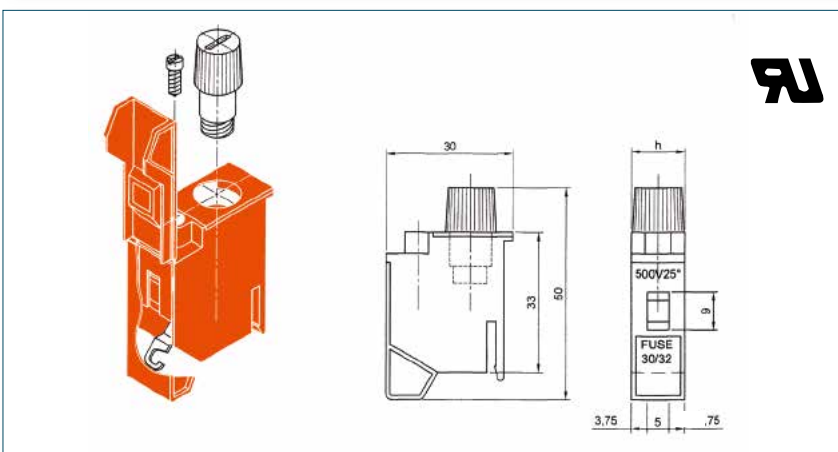

TYPE	REF
MORSETTI 30A 1P FUSE ARANCIO	K-M30A1PFUAR
MORSETTI 30A 1P FUSE GRIGIO	K-M30A1PFUG

FUSIBILE 6X32
WIRE RANGE 10-20
mm² 4

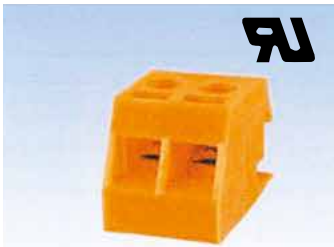

TS 2.5

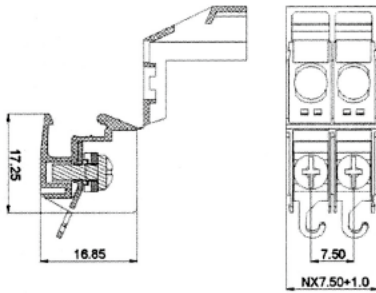

**W-M16A2PTS
W-M16A3PTS
WIRE RANGE 14-24
mm² 2,5**

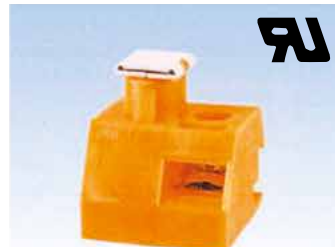

TSF 2.5

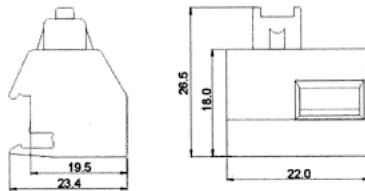

**FUSIBILE 5X20
W-M16AFUTSF
WIRE RANGE 14-20
mm² 2,5**



TS 4

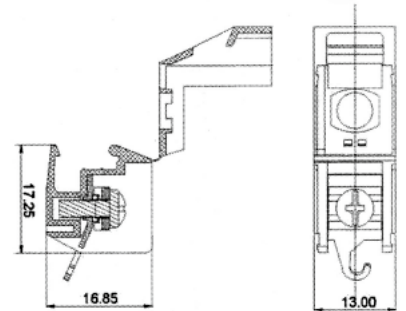

**W-M30A1PTS
WIRE RANGE 12-20
mm² 4**

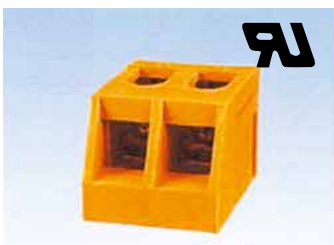

TSB 2.5

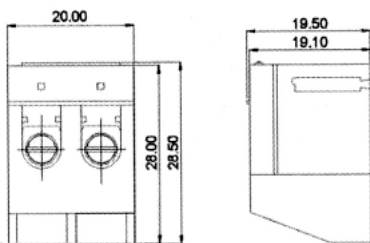

**PH-M16A2PTSB
PH-M16A3PTSB
WIRE RANGE 12-20
mm² 2,5**



TSB 4

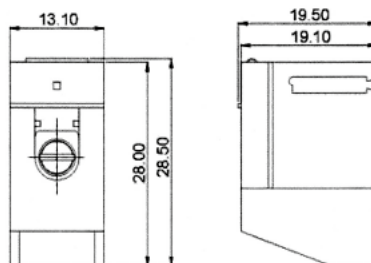

**PH-M30A1PTSB
WIRE RANGE 12-20
mm² 4**

SLIM



TSCB 4

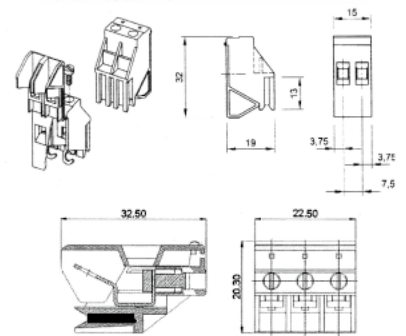

**PH-M16A1PTSCB
PH-M16A2PTSCB
PH-M16A3PTSCB
WIRE RANGE 10-20
mm² 2,5**

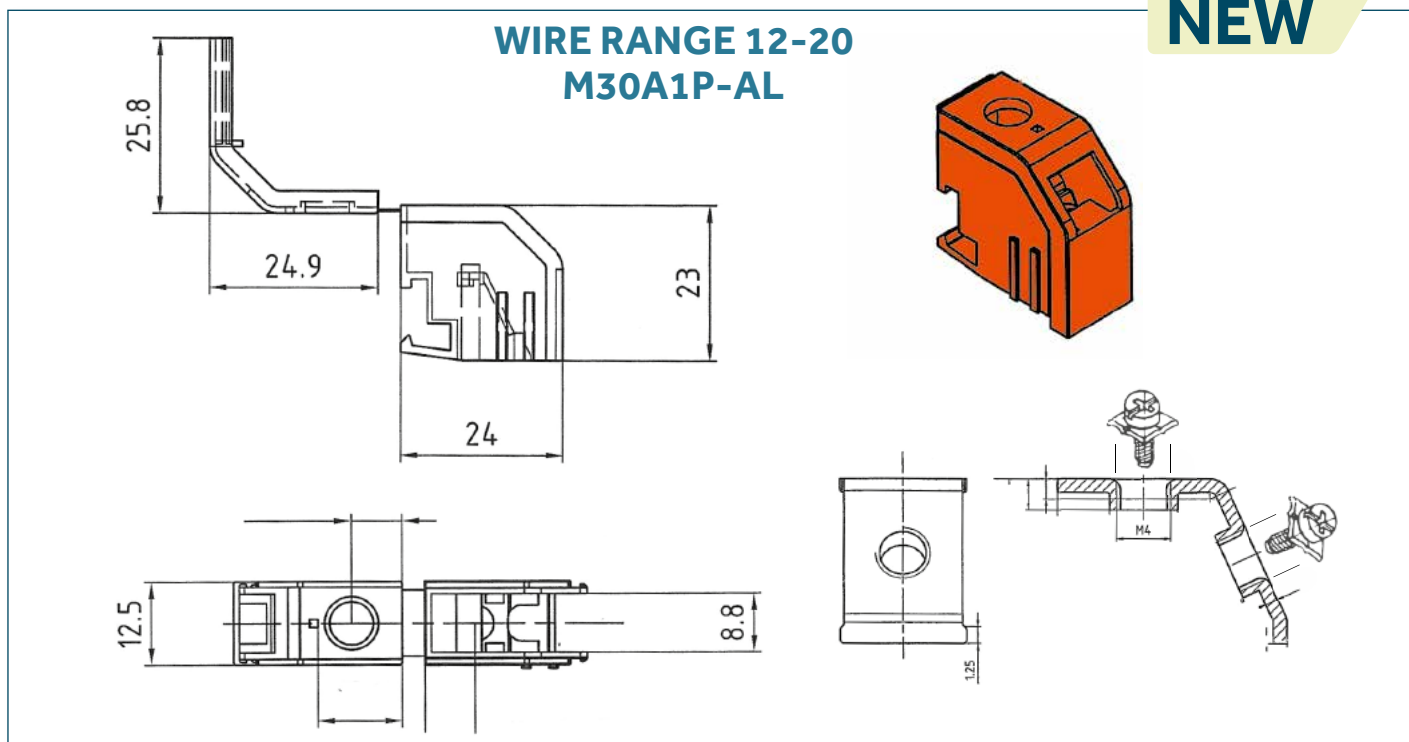
NEW

CERTIFICATIONS

XCFR2.E355624 - Terminal-block-Component

CAT. NO	Wire range AWG	Wire Type, Cu	FW	Torque in-lbs	V	A	UG	CA
K-M16A1PK	10-20	CU	2	Min. 7,1 (0,8 Nm) Max. 8,9 (1,0 Nm)	300	16	B,D ^(A)	2(105),4
K-M16A2PK	10-20	CU	2	Min. 7,1 (0,8 Nm) Max. 8,9 (1,0 Nm)	300	16	B,D ^(A)	2(105),4
K-M30A1PK	10-20	CU	2	Min. 11,5 (1,3 Nm) Max. 13,5 (1,5 Nm)	300	30	B	2(105),4
K-M16A1PFU	10-20 ^(B)	CU	2	Min. 7,1 (0,8 Nm) Max. 8,9 (1,0 Nm)	300 600	16 16	B,C D ^(A)	2(105),4 2(105),4
K-M30A1PFU	10-20	CU	2	Min. 7,1 (0,8 Nm) Max. 8,9 (1,0 Nm)	600	30	B,C	2(105),4
W-M16A2PTS	12	CU	2	Min. 4,4 (0,5 Nm) Max. 5,4 (0,6 Nm)	300 600	16 16	B,C D ^(A)	2(105),4 2(105),4
W-M16A3PTS	12	CU	2	Min. 4,4 (0,5 Nm) Max. 5,4 (0,6 Nm)	300 600	16 16	B,C D ^(A)	2(105),4 2(105),4
W-M16AFUTSF	14	CU	2	Min. 7,1 (0,8 Nm) Max. 8,9 (1,0 Nm)	600	15-16 ^(B)	B,C	2(105),4
PH-M16A2PTSB	12	CU	2	Min. 7,1 (0,8 Nm) Max. 8,9 (0,8 Nm)	300 150	16 16	B,D ^(D) C	2 (105), 4 2(105),4
PH-M16A1PTSB	12	CU	2	Min. 4,4 (0,5 Nm) Max. 5,4 (0,6 Nm)	300 600	16 16	B,D ^(D) C	2(105),4 2(105),4
PH-M16A2PTSB	10-20	CU	2	Min. 4,4 (0,5 Nm) Max. 5,4 (0,6 Nm)	300 600	16 16	B,C D ^(C)	2(105),4 2(105),4
PH-M16A3PTSB	10-20	CU	2	Min. 4,4 (0,5 Nm) Max. 5,4 (0,6 Nm)	300 600	16 16	B,C D ^(C)	2(105),4 2(105),4



MK 2.5

Larghezza / Lunghezza / Larghezza copertura	6 / 41 / 1.5 mm
Altezza (NS35/7.5 - NS35/15 - NS32)	42.5 / 50 / 42.5 mm
Tensione nominale / MAX corrente di carico	800V / 24A
Tensione impulsiva di dimensione	8kV/3
Grado di inquinamento	
sezione nomilale / Sezione conduttori	0.5 - 2.5 mm ² / 22 - 12 AWG
Lunghezza spelatura	10 mm
filettatura / Coppia di serraggio	M2.5 / 0.4 - 0.8Nm
Tipo di materiale a norma UL94	PA/V-0



MK 4

Larghezza / Lunghezza / Larghezza copertura	6,5 / 42 / 1.5 mm
Altezza (NS35/7.5 - NS35/15 - NS32)	47.5 / 55 / 47.5 mm
Tensione nominale / MAX corrente di carico	800V / 32A
Tensione impulsiva di dimens.	8kV/3
Grado di inquinamento	
sezione nomilale / Sezione conduttori	0.5 - 4 mm ² / 22 - 12 AWG
Lunghezza spelatura	12 mm
filettatura / Coppia di serraggio	M3 / 0.5 - 1.0Nm
Tipo di materiale a norma UL94	PA/V-0



MK 6

Larghezza / Lunghezza / Larghezza copertura	8 / 42 / 1.5 mm
Altezza (NS35/7.5 - NS35/15 - NS32)	47.5 / 55 / 47.5 mm
Tensione nominale / MAX corrente di carico	800V / 41A
Tensione impulsiva di dimens.	8kV/3
Grado di inquinamento	
sezione nomilale / Sezione conduttori	0.5 - 6 mm ² / 22 - 8 AWG
Lunghezza spelatura	12 mm
filettatura / Coppia di serraggio	M3.5 / 0.8 - 1.6Nm
Tipo di materiale a norma UL94	PA/V-0



MK 10

Larghezza / Lunghezza / Larghezza copertura	10 / 42 / 1.5 mm
Altezza (NS35/7.5 - NS35/15 - NS32)	47.5 / 55 / 47.5 mm
Tensione nominale / MAX corrente di carico	800V / 57A
Tensione impulsiva di dimens.	8kV/3
Grado di inquinamento	
sezione nomilale / Sezione conduttori	1.5 - 10 mm ² / 14 - 6 AWG
Lunghezza spelatura	12 mm
filettatura / Coppia di serraggio	M4 / 2.0Nm
Tipo di materiale a norma UL94	PA/V-0



MK 16

Larghezza / Lunghezza / Larghezza copertura	12 / 50 / 1.5 mm
Altezza (NS35/7.5 - NS35/15 - NS32)	53.5 / 61 / 53.5 mm
Tensione nominale / MAX corrente di carico	800V / 76A
Tensione impulsiva di dimens.	8kV/3
Grado di inquinamento	
sezione nomilale / Sezione conduttori	4 - 16 mm ² / 22 - 6 AWG
Lunghezza spelatura	15 mm
filettatura / Coppia di serraggio	M4 / 2.0 - 2.4Nm
Tipo di materiale a norma UL94	PA/V-0



MK 35

Larghezza / Lunghezza / Larghezza copertura	18 / 58 / 1.5 mm
Altezza (NS35/7.5 - NS35/15 - NS32)	63.5 / 71 / 63.5 mm
Tensione nominale / MAX corrente di carico	800V / 125A
Tensione impulsiva di dimens.	8kV/3
Grado di inquinamento	
sezione nomilale / Sezione conduttori	10 - 35 mm ² / 8 - 2 AWG
Lunghezza spelatura	20 mm
filettatura / Coppia di serraggio	M6 / 5.0Nm
Tipo di materiale a norma UL94	PA/V-0



MK 70

Larghezza / Lunghezza / Larghezza copertura	22 / 75 / 1.5 mm
Altezza (NS35/7.5 - NS35/15 - NS32)	87 / 94.5 / 87 mm
Tensione nominale / MAX corrente di carico	800V / 192A
Tensione impulsiva di dimens.	8kV/3
Grado di inquinamento	
sezione nomilale / Sezione conduttori	16 - 70 mm ² / 6 - 00 AWG
Lunghezza spelatura	24 mm
filettatura / Coppia di serraggio	M8 / 6 - 12Nm
Tipo di materiale a norma UL94	PA/V-0



E-MK

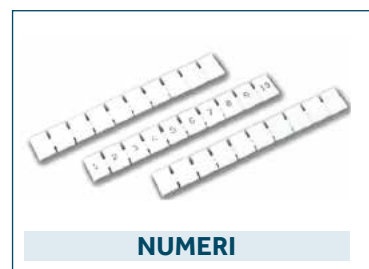

NUMERI



**D-MK2.5 D-MK4
D-MK16 D-MK35
D-MK70**

**DISPONIBILI
VITE MK/4
VITE MK/6**

MORSETTI DI TERRA UNIVERSALI



MK 2.5-PE

Larghezza / Lunghezza	6 / 36.5 mm - 6 / 56 mm
Altezza (NS35/7.5 - NS35/15 - NS32)	- / - / 49.5 mm - 40 / 47.5 / - mm
Sezione nominale / Sezione conduttori	0.5 - 2.5 mm ² / 22 - 14 AWG
Lunghezza spelatura	10 mm
Punto di connessione: filettatura / coppia di serraggio	M2.5 / 0.4 - 0.7Nm
Fissaggio: filettatura / coppia di serraggio	M3 / 0.5 - 1.0Nm
Tipo di materiale a norma UL94	PA/V-0



MK 4-PE

Larghezza / Lunghezza	6.5 / 40 mm - 6.5 / 56 mm
Altezza (NS35/7.5 - NS35/15 - NS32)	- / - / 51.5 mm - 44 / 51.5 / - mm
Sezione nominale / Sezione conduttori	0.5 - 4 mm ² / 22 - 10 AWG
Lunghezza spelatura	12 mm
Punto di connessione: filettatura / coppia di serraggio	M3 / 0.5 - 1.0Nm
Fissaggio: filettatura / coppia di serraggio	M3 / 0.5 - 1.0Nm
Tipo di materiale a norma UL94	PA/V-0



MK 6-PE

Larghezza / Lunghezza	8 / 56 mm
Altezza (NS35/7.5 - NS35/15 - NS32)	44 / 51.5 / - mm
Sezione nominale / Sezione conduttori	0.5 - 6 mm ² / 20 - 8 AWG
Lunghezza spelatura	12 mm
Punto di connessione: filettatura / coppia di serraggio	M3.5 / 1.2 - 2.0Nm
Fissaggio: filettatura / coppia di serraggio	M3 / 0.5 - 1.0Nm
Tipo di materiale a norma UL94	PA/V-0



MK 10-PE

Larghezza / Lunghezza	10 / 40 mm - 10 / 56 mm
Altezza (NS35/7.5 - NS35/15 - NS32)	- / - / 51.5 mm - 44 / 51.5 / - mm
Sezione nominale / Sezione conduttori	0.5 - 10 mm ² / 20 - 8 AWG
Lunghezza spelatura	12 mm
Punto di connessione: filettatura / coppia di serraggio	M4 / 1.2 - 2.0Nm
Fissaggio: filettatura / coppia di serraggio	M3 / 0.5 - 1.0Nm
Tipo di materiale a norma UL94	PA/V-0



MK 16-PE

Larghezza / Lunghezza	12 / 50 mm - 12 / 50 mm
Altezza (NS35/7.5 - NS35/15 - NS32)	- / - / 57.5 mm - 50 / 57.5 / - mm
Sezione nominale / Sezione conduttori	2.5 - 16 mm ² / 12 - 6 AWG
Lunghezza spelatura	16 mm
Punto di connessione: filettatura / coppia di serraggio	M4 / 1.2 - 2.4Nm
Fissaggio: filettatura / coppia di serraggio	M3 / 0.8 - 1.0Nm
Tipo di materiale a norma UL94	PA/V-0



MK 35-PE

Larghezza / Lunghezza	16 / 58 mm - 16 / 58 mm
Altezza (NS35/7.5 - NS35/15 - NS32)	- / - / 67.5 mm - 60 / 67.5 / - mm
Sezione nominale / Sezione conduttori	10 - 35 mm ² / 8 - 2 AWG
Lunghezza spelatura	20 mm
Punto di connessione: filettatura / coppia di serraggio	M6 / 2.5 - 5.0Nm
Fissaggio: filettatura / coppia di serraggio	M4 / 1.2 - 1.6Nm
Tipo di materiale a norma UL94	PA/V-0

MORSETTI UNIVERSALI CON GUIDA DIN SERIE KT1 IEC 947-7-1



KT1-35

Larghezza - Lunghezza	15,2/50/-
Altezza (mm)	-/69,5/67
Tensione Nominale	1000V/150A
Sezione Conduttori (mm ²)	35-50
Sezione Conduttori	18-0AWG

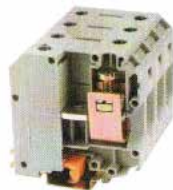

KT1-50

Larghezza - Lunghezza	20/70,5/-
Altezza (mm)	-/83,5/81,5
Tensione Nominale	1000V/150A
Sezione Conduttori (mm ²)	25-50
Sezione Conduttori	6-0AWG



KT1-95

Larghezza - Lunghezza	31/100/-
Altezza (mm)	-/118,5/116
Tensione Nominale	1000V/309A
Sezione Conduttori (mm ²)	50-150
Sezione Conduttori	2-300AWG



KT1-150

Larghezza - Lunghezza	31/100/-
Altezza (mm)	-/118,5/116
Tensione Nominale	1000V/309A
Sezione Conduttori (mm ²)	50-150
Sezione Conduttori	2-300AWG



KT1-240

Larghezza - Lunghezza	36/100/-
Altezza (mm)	-/131,5/129,5
Tensione Nominale	1000V/415A
Sezione Conduttori (mm ²)	70-240
Sezione Conduttori	00-500AWG



FERMI KT1-E



NUMERI



TOROIDAL SCHEISSEN UND RINGE
TOROIDAL DISCS AND RINGS
DISCHI E ANELLI TOROIDALI
DISQUES ET ANNEAUX TORIQUES

ANELLI PER NUCLEI TOROIDALI / RING FOR TOROIDAL-CORE

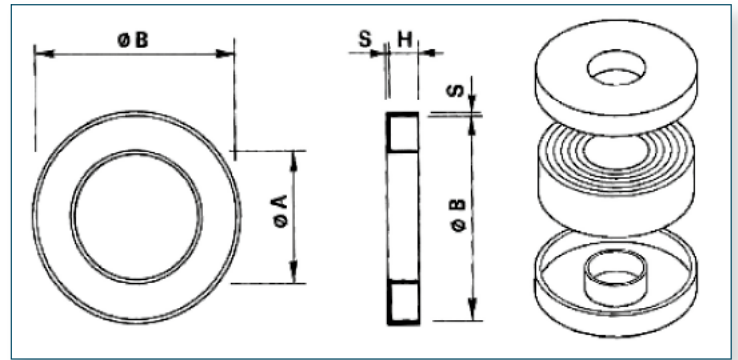

REF.	Ø A	Ø B	H	S
TR 1524	15,1	24,5	5,5	0,60
TR 1625	15,5	25	5,5	0,60
TR 1628	16	28	5,5	0,60
TR 2031	19,2	31	4,8	0,6
TR 2642	25,5	42,2	6,5	0,8
TR 3050	30	50	7/12	0,7
TR 3054	30	54	7	0,7
TR 3060	30	60	7	0,6
TR 3068	30	68	7	0,6
TR 3355	33	55	7	0,6
TR 3450	34	50	8	0,7
TR 3552	35	52	5,7	0,6
TR 3555	35	55	7	0,6
TR 3560	35	60	8	0,7
TR 3565	35	65	7	0,7
TR 3570	35	70	7	0,6
TR 3745	37	45	7	0,6
TR 3755	37	55	7	0,6
TR 3761	37	61	6	0,7
TR 3846	38	46	7	0,7
TR 3852	38	52	7	0,7
TR 3866	38	66	7	0,7
TR 3872	38	72	7	0,7
TR 3961	39,5	61	7,5	0,6
TR 4050	41,5	51,5	12	0,7
TR 4065	40	65	7/10	0,6
TR 4070/7	40	70	7	0,6
TR 4070/9	40	70	9	0,6
TR 4075	39,5	75	7/11	0,5
TR 4080	40	81	7	0,7
TR 4083	40	83	5	0,7
TR 4085	39,6	85,9	9	1
TR 40105	40	105	7	0,7
TR 40110	40	110	7	0,7
TR 4175	41	75	7	0,7
TR 4272	42	72	7	0,7
TR 4287	42	87	7	0,7

REF.	Ø A	Ø B	H	S
TR 4570	45	70	7	0,7
TR 4575	45	75	7	0,7
TR 4580	44,1	80,9	8	0,8
TR 4585	45	85	7	0,8
TR 45135	45	135	7	0,8
TR 4680	46	80	7	0,8
TR 49101	49	107	7	0,8
TR 5080	50	80,5	7	0,8
TR 5085	50	86	7	0,8
TR 5090	50	90	7	0,8
TR 5095	50	95	7	0,8
TR 50100/5	50	100,5	5	0,8
TR 50100/7	50	100	7	0,8
TR 50110/5	50	110	5	0,8
TR 50110/7	50	110	7	0,8
TR 50115	50	115	6	0,6
TR 50120	50	120	7,5	0,6
TR 5585	55	85	7	0,8
TR 5595	55	95	11	0,8
TR 55101	55	101	7	0,8
TR 55120	55	120	7	1
TR 6085	60	85	7	1
TR 6090	60	90	7	1
TR 6095	60	95	14	1
TR 60100/8	60	100	8	1
TR 60100/11	60	100	11	1,0
TR 60105	59,3	105	18	0,8
TR 60108	60	108	12	0,8
TR 60110	60	110	7	0,8

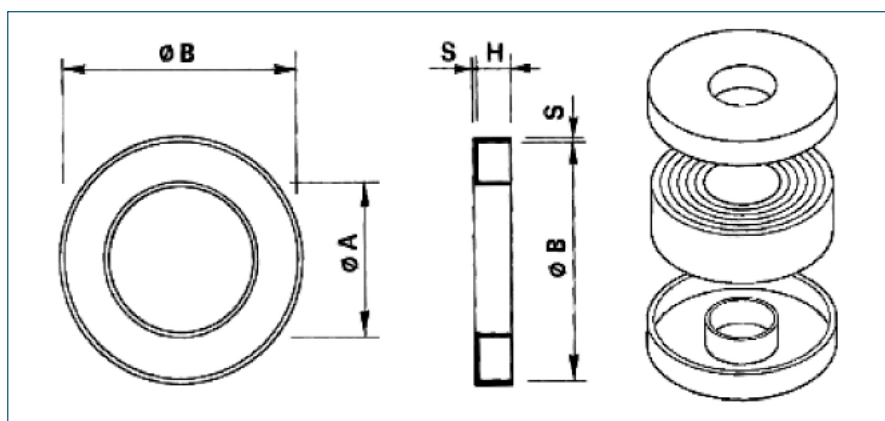

REF.	Ø A	Ø B	H	S
TR 60115	60	115	10	1
TR 60120	60	120	7	0,8
TR 60130	60	130	7	1,2
TR 60135	60	135	7	1
TR 60140	60	140	7	1
TR 60180	60	180	7	1
TR 62104	62,5	104	7	1
TR 63132	62,5	131,5	20	1
TR 65105	65	105	7	1
TR 65170	65	170	7	1
TR 68114	68	114	7	1
TR 7076	70	76	7	1
TR 70100	70	100	5	1
TR 70110	70	110	8	1,2
TR 70115	70	115	7	1
TR 70120	70	120	7	1
TR 70125	70	125	7	1
TR 70130	70	130	7	1
TR 70132	70	132	7	1
TR 70135	70	135	7	1,2
TR 70140	70	140	7	1
TR 70150	70	150	7	1
TR 70180	70	180	7	1
TR 7585	75	85	7	1
TR 75185	75	185	7	1
TR 80140	80	140	7	1,2
TR 80145	80	145	7	1
TR 80150	80	150	7	1,2
TR 80160	80	160	7	1

REF.	Ø A	Ø B	H	S
TR 80170	80	170	7	1
TR 85125	85	125	7	1
TR 88160	88	160	7	1
TR 89199	89,5	199	25	1,2
TR 89203	89,5	203,5	25	1,2
TR 9098	90	98	7	1
TR 90180	90,5	180	7	1,2
TR 90200	90,5	200	7	1,2
TR 100180	100	180	7	1,2
TR 100230	100	230	7	1,2
TR 105145	105	145	5	1,2
TR 105220	105	220	7	1,2
TR 110220	110	220	7	1,2
TR 120170	120	170	7	1,1
TR 120250	120	250	7	1,2
TR 123172	123	172	7	1,2
TR 125210	125	210	7	1,2
TR 125240	125	240	7	1,2
TR 128163	128	163	7	1,2
TR 128168	128	168	7	1,2
TR 130270	130	270	7	1,2
TR165185	165	185	7	1,1

**Il pessimista vede difficoltà in ogni opportunità.
L'ottimista vede l'opportunità in ogni difficoltà.**

DISCHI PER TRASFORMATORI TOROIDALI

ACCIAIO TROPICALIZZATO (STEEL)

TYPE	A	B	S	DISCO GOMMA
DISCO 50-FE	50	5,0	1,1	Disco 50 - G
DISCO 60-FE	60	5,5	1,2	Disco 60 - G
DISCO 78-FE	78	8,2	1,2	Disco 80 - G
DISCO 90-FE	90	7,4	1,2	Disco 90 - G
DISCO 100-FE	110	7,4	1,5	Disco 110 - G
DISCO 130-FE	130	9,3	1,5	Disco 130 - G

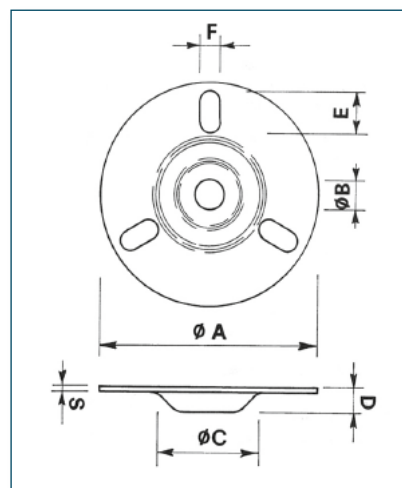

MATERIALE TERMOPLASTICO RP3 155°

TYPE	A	B	C	D	E	F	S
DISCO 60/6-11	60	6,3 e 11	30	7,0			1,8
DISCO 80/6-11	80	6,3 e 11	35	8,2	15		1,8
DISCO 90/6-11	90	6,3 e 11	42	10,0	18	8	2,0
DISCO 110/6-11	110	6,3 e 11	42	10,0	28	8	2,5
DISCO 130/6-11	130	6,3 e 11	42	10,0	38	8	2,5

CONTENITORI PER NUCLEI TOROIDALI APERTI

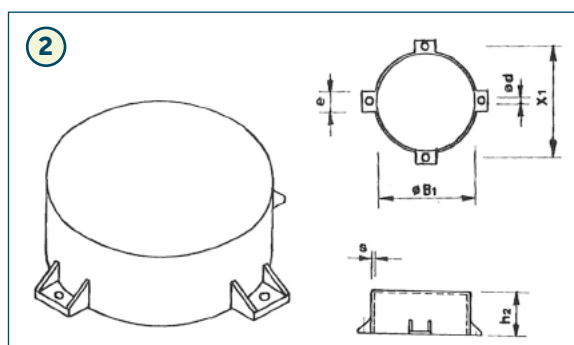
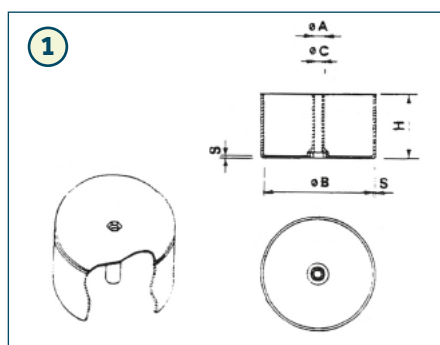

TYPE	ØA	B1	ØC	Ød	H	S	X1	DISEGNO
SO TR 50	9,6	51,7	6,5		32,5	1,5		1
SO TR 69		68		3,3	33,2	1,5	80	2
SO TR 79		68		3,3	36,2	1,5	90	2
SO TR 93	9,6	90	6,5		55	1,5		1
SO TR 96	9,6	93,5	6,5		44,2	1,5		1
SO TR 105		104,5		4,3	43,2	1,5	115	2
SO TR 108	9,6	105	6,5	4,3	55	1,5		1
SO TR 123A	9,6	119,8	6,5		55	1,7		1
SO TR 123B	9,6	119,8	6,5		65	1,7		1
SO TR 150	9,6	146,6	6,5		65	1,7		1

SCATOLE PER ILLUMINOTECNICA

TYPE	REF.	M	A	B	C	D	E	L	S
SIL 84	SIL 84	8	44,6	26,0	22,3	10,6		84,2	1

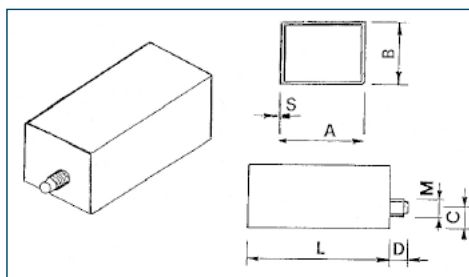

CONTENITORI E COPERCHI PER TRASFORMATORI TOROIDALI

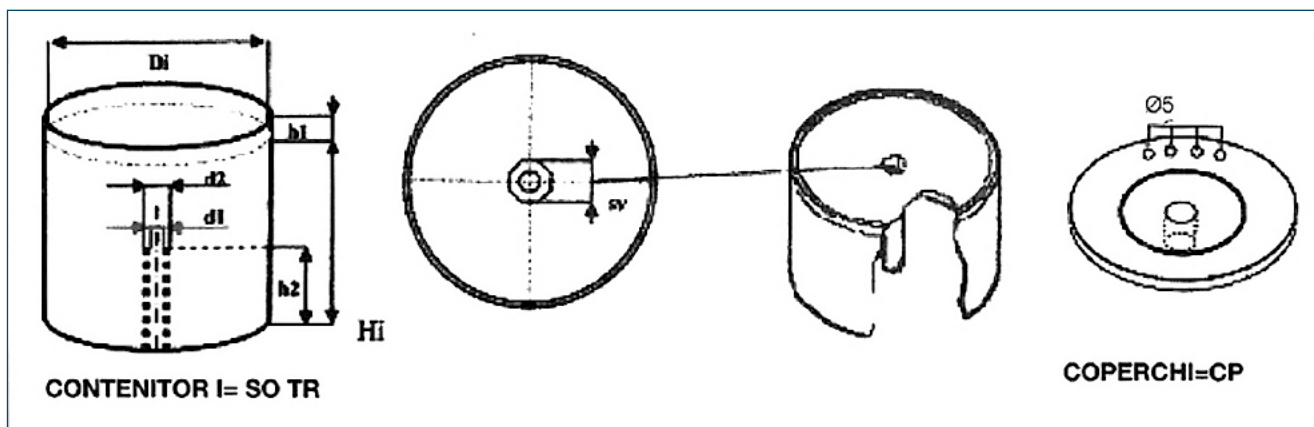

TYPE	Di	Hi	h1	h2	d1	d2	SV
SO TR 63	63,8	59,5		50,5	3,5	6	
SO TR 80	80	39,5		38	5,2	8	7
SO TR 68	68	57	4,85	49,5	10,9	13,8	
SO TR 80,5	80,5	62	4,85	55,3	15,9	18,7	
COP 68	68						
COP 63	63,8						
COP 80,5	80,5						

STAGNO - TIN

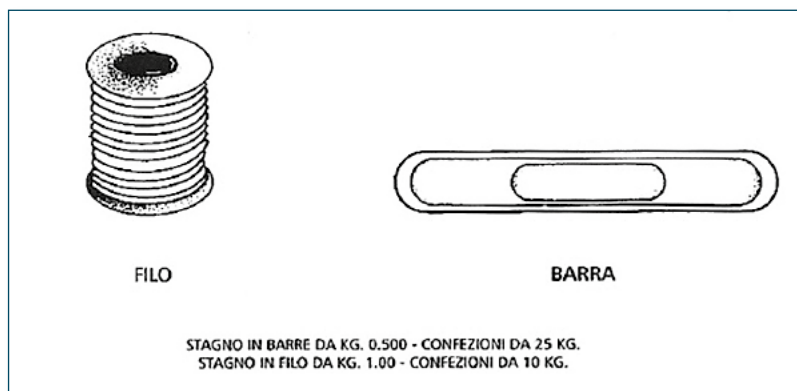

TYPE	Stagno	Piombo	Antimonio	Rame	Ferro	Zinco	Argento	Arsenico	Filo Barra
SB 63-37	62,5 - 63,5	Rimanenza	0,20 - 0,50	0,005 - 0,08	0,02	0,005		0,03	F/B
SB 60-40	59,5 - 61,5	Rimanenza	0,20 - 0,50	0,005 - 0,08	0,02	0,005		0,03	F/B
SN 96,5 AG 3 Cu 0,5	96 - 96,5			0,5			3		B
SN 97 Cu 3	90,5 - 97			3					B
SN 99 AG 0,3 Cu 0,7	99			0,7			0,3		F/B
SN 99 SP	99 - 99,8								F
SN 99 AG 0,1 Cu 0,9	99 - 99,5			0,9			0,1		F
SN 99,3 Cu 0,7	99 - 99,3			0,7					F

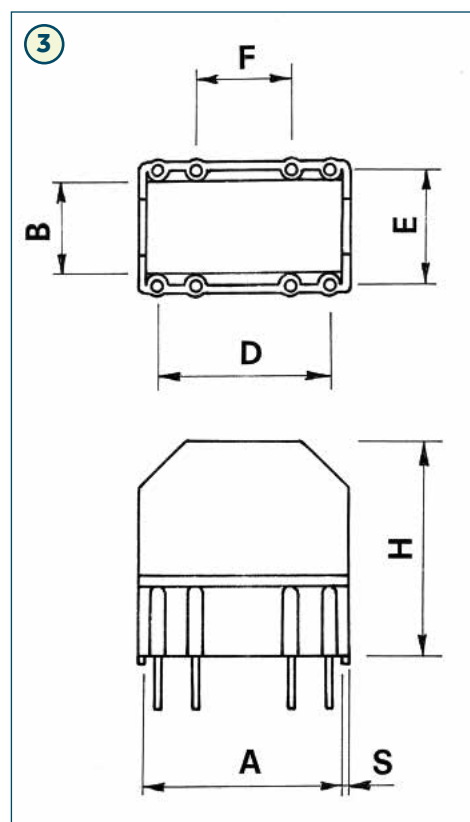
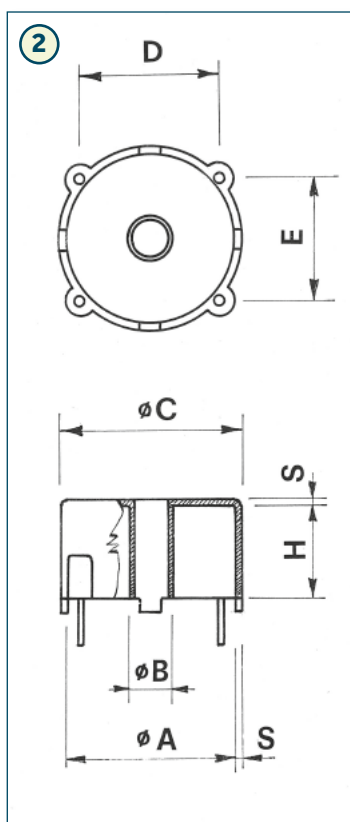
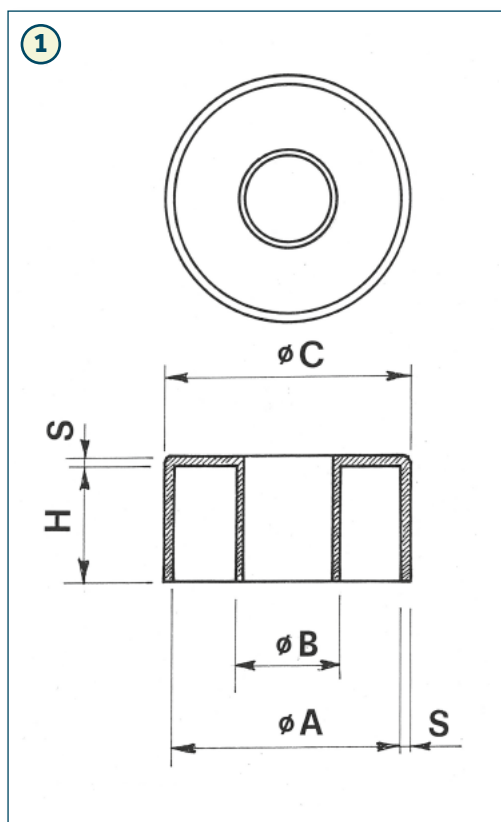

TYPE	A	B	C	H	S	NOTE	disegno
SOTR 28	28,6	11,8	30,6	15	1	CON FORO	1
SOTR 38	38,5	11,7	41,8	20	1,25	SENZA CENTRALE	1

TYPE	A	B	C	D	E	H	S	numero term.	NOTE	disegno
SOTR 15/2	15,2		17	15	10	9,5	0,9	4	SENZA FORO CENTRALE	2
SOTR 15/3	15,8	3,9	17,61	14	12,5	8,1	0,9	4	CON FORO	2
SOTR 15/4	15,8	3,9	17,6	14	12,5	14,1	0,9	4	CON FORO	2
SOTR 20	20,5		21,9	20	12,5	12,3	0,7	4	SENZA FORO CENTRALE	2
SOTR 23	23,9	5,9	25,7	20	17,5	13,1	0,9	4	CON FORO	2
SOTR 24	24		26	20	17,5	13	1	4	SENZA FORO CENTRALE	2
SOTR 25	24,9		26,9	25	15	14,5	1	4	SENZA FORO CENTRALE	2
SOTR 30	30		32	30	20	17	1	4	SENZA FORO CENTRALE	2

TYPE	A	B	D	E	F	H	S	NU. ± 1 TERMINALI	disegno
FIL 16	16	8	15	10	5	17,5	0,8	4+4	3
FIL 21	21	9,3	20	12,5	10	23	0,9	4+4	3
FIL 25	25,2	12	22,5	15	12,5	28	0,9	4+4	3
FIL 30	30	13		15	12,5	32	1	2+2	3

TYPE	COLONNA	PACCO	LAMIERINO EI
CAV 5+1	5	5	16 X 19
CAV 6,5 + 7	6,5	7	19,5 X 25,5
CAV 6,5 + 10	6,5	10	19,5 X 25,5
CAV 10 + 10	10	10	27 X 33
CAV 10 + 15	10	15	27 X 33
CAV 13 + 13	13	13	34 X 40
CAV 13 + 15	13	15	34 X 40
CAV 14 + 15	14	15	35 X 42
CAV 14 + 18	14	18	37 X 44
CAV 16 + 16	16	16	40 X 48
CAV 16 + 20	16	20	40 X 48
CAV 16 + 25	16	25	40 X 48
CAV 18 + 18	18	18	45 X 45
CAV 20 + 20	20	20	50 X 60
CAV 20 + 25	20	25	50 X 60
CAV 20 + 30	20	30	50 X 60
CAV 20 + 35	20	35	50 X 60
CAV 22 + 22	22	22	58 X 68 e 55 x 66
CAV 22 + 25	22	25	58 X 68 e 55 x 66
CAV 22 + 30	22	30	58 X 68 e 55 x 66
CAV 22 + 35	22	35	58 x 68
CAV 22 + 40	22	40	58 x 68
CAV 25 + 25	25	25	62,5 x 75
CAV 25 + 30	25	30	62,5 x 75
CAV 25 + 35	25	35	62,5 x 75
CAV 25 + 40	25	40	62,5 x 75
CAV 28 + 28	28	28	70 x 84
CAV 28 + 30	28	30	70 x 84
CAV 28 + 35	28	35	70 x 84
CAV 28 + 40	28	40	70 x 84
CAV 28 + 45	28	45	70 x 84
CAV 32 + 32	32	32	80 x 96
CAV 32 + 35	32	35	80 x 96
CAV 32 + 40	32	40	80 x 96

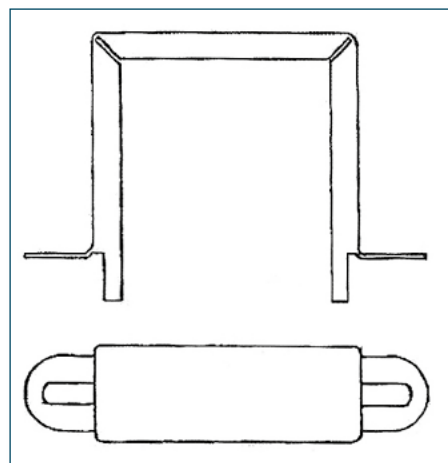

ALTRI TIPI E VERSIONI A RICHIESTA

**OTHER TYPES AND VERSIONS
UPON REQUEST**

**Se vuoi crescere devi qualcosa di diverso
della maggior parte delle persone.**

La strada per il successo è sempre in costruzione.

CASSE PER TRASFORMATORI TRIFASE "FAI DA TE"

CASES FOR THREE-PHASE TRANSFORMERS DIY METALLIKISTEN FÜR DREIPHASIGE TRASFORMATOREN

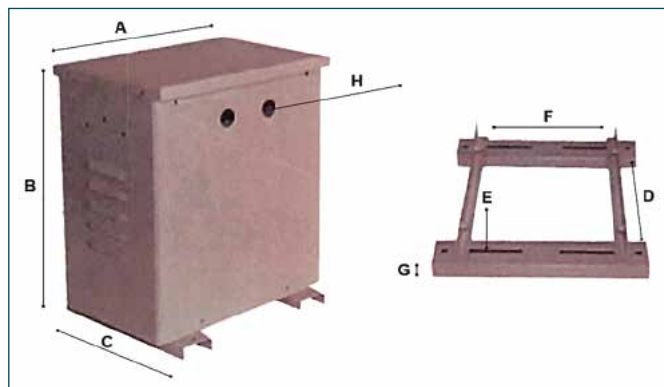

COLONNA	A	B	C	D	E	F	G	H	I
30	242	220	140	140	40X6	90	6	23	40
40	280	315	175	200	56X6	95	6	23	50
50	340	350	242	200	80X6	116	6	28	50
60	440	400	240	320	80X6	116	12	28	50
70	460	500	302	350	55X12	155	28	28	70
80	525	550	320	400	55X12	175	28	38	70
90	600	625	340	400	80X12	170	28	38	70
100	700	740	450	500	86X12	385	28	38	70
110	795	860	555	550	80X12	385	28	38	70
120	910	940	590	605	100X12	425	12	38	70

TUBETTI - GUAINA / INSULATING HOSE

T/VGS

Guaine in vetro silicone
da 1.5, 2.5, 4 Kw
flessibile e auto estinguente
colore rosso mattone
con classe di isolamento H 180°

GUAVP

Guaine in vetro poliuretano 4 Kw
ottima resistenza all'abrasione
colore paglierino
con classe di isolamento F 155°

GUACR

Guaine in vetro acrilico da 3kw
ottima resistenza meccanica
e dielettrica
colore giallo
con classe di isolamento F 155°

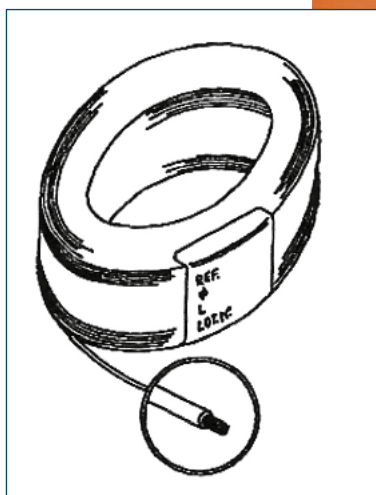

Nota

Disponibile in tutti i diametri

NASTRI ADESIVI DIELETRICI / DIELECTRIC ADHESIVE RIBBONS

DIELEKTRISCHE KLEBEBÄNDER

TIPO type	TIPO SUPPORTO Backing type	SPESSORE SUPPORTO Baking thickness	SPESSORE TOTALE Total thickness	TIPO ADESIVO Adhesive type	COLORE Colour	ADESIVITÀ ACCIAIO Peel adhesive	CARICO DIROTTURA Tensile strenght	ALLUNGAMENTO A.R. Elongation	RIGIDITÀ DIELETRICA Breakdown voltage	CORROSIONE ELETTROLIT. Electrolytic corrosion	CLASSE TERMICA Thermal class	OMOLOGAZIONE Certifications	ESEMPI DI APPLICAZIONE End use suggestions
		mm.	mm.										
GL 96	Tessuto di vetro Glass cloth	0,10	0,18	SIL	Bianco White	3,0	280	05	2,5	1	180		Grandi motori: elevata resistenza, ininfiammabile Heavy duty motors: high winding tension and high use temperature
P 31	Film PET PET film	0,023	0,06	R-TS	Giallo Yellow	4,5	45	90	4,5	1	130		Componenti elettronici. Piccoli trasformatori. Conformabile Electronic components. Small transformers & coils
PT 25	Film PET non tessuto PET film non woven	0,09	0,13	R-TS	Bianco White	5,0	55	35	4,8	1	130		Avvolgimenti in genere : buona adesività e conformabilità Coils and transformers. Conformable and covering copper wires
GX 50	NOMEX* - fibre di vetro NOMEX* - glass fibers	0,10	0,15	R-TS	Beige Cream	5,0	50	03	1,0	1	155		Trasformatori. Ottima resistenza meccanica Insulation with high mechanical and ageing performances
PX 50	NOMEX* Film PET NOMEX PET film	0,09	0,14	R-TS	Beige Cream	6,0	70	10	5,5	1	155		Bobine e motori. Alta rigidità dielettrica e meccanica Coils and motors. Combining high breakdown voltage and ageing
CS 60	Carta semicrespata Semi-craped paper	0,09	0,13	R-TX	Beige Cream	3,0	30	09	0,8	1	80		Avvolgimenti in genere. Conformabile Coils and transformers. Conformable
RE	Reggetta + fibra vetro	0,09	0,13	R-TX	Bianco White	3,0	250	10	0,8	1	80		Per trasformatori: usata per bloccaggio carta o stecche



(*) Nomex e Kapton sono marchi registrati Dupont de Nemours.

Adesivi, Adhesives

R-TS Gomma termosetting = rubber thermosetting
R-TX Gomma reticolata = Crosslinked rubber
SIL Siliconico = Siliconic

CARTA BACHELIZZATA - VETRORESINA

CARATTERISTICHE TECNICHE DEI MATERIALI

	CORRISPONDENZA NORMA					CARATTERISTICHE FISICHE					CARATTERISTICHE MECCANICHE								CARATTERISTICHE ELETTRICHE			
	CEI	AIEE	DIN 7735	NEMA	MIL-P	RESINA	SUPPORTO	COLORE	P _s Kg/dm ²	ASSORB. H ₂ O 24H - 23°C %	COMPRESS. Kg/dm ²	TRAZIONE Kg/dm ²	FLESSIONE Kg/dm ²	RESILIENZA Kgcm/dm ²	Dur. ROCKWELL HR M	TRACIABILITÀ A FREDDO mm.	TRACIABILITÀ A CALDO 70°C mm.	RESISTENZA TERMICA (continua) °C	TRA SPINE Ohm	SUPERFICIE Ohm	NORMALE ALLA STRATIFICAZIONE KV/mm.	PARALLELA ALLA STRATIFICAZIONE KV
BACHELITE	TR		HP 2061	P	78A HSP	Fenolica	Cellulosa pura	MAR-RONE	1,4	2,0	1800	900	1100	20	90	1,5	2,5	130	10 ³	10 ³	10	15
VETRORESINA	G10	B	HgW2 372	G10	18177 GEE	EPOX	Tessuti di vetro	VERDE	1,9	0,1	4000	1500	3500	100	110	2,5	2,0	155	10 ¹²	10 ¹²	40	40
VETRORESINA	GP03		Hm24 72	GP03		Polies-tere	Tessuti di vetro	ROSSO	1,85	0,2	2600	1000	2000	100	110	-	-	155	10 ¹²	10 ¹²	30	25

Spessori: mm. 0,5/1/1,5/2/3/4/5/6/7/8/9/10....30

(I-ELE) ELECTRON E (I-LAT) LATHEROIDE

ISOLANTE ELETTRICO CLASSE E 120°C

L'ELECTRON è un cartone pressato di alta qualità, fabbricato esclusivamente con fibre cellulosiche di elevate caratteristiche, senza alcun impiego di colle, cariche, colori.

L'ELECTRON è il solo da noi usato nella fabbricazione dei tubi e rocchetti

L'ELECTRON è un materiale omologato dai Laboratori Italtrafo in conformità alle loro norme.

PROPRIETÁ E CARATTERISTICHE	UNITÁ DI MISURA	ELECTRON IN ROTOLI	ELECTRON IN FOGLI
1/Peso specifico	g/cm ³	1,10-1,25	1,10-1,25
2/Umidità allo stato di fornitura	%	6-8	6-8
3/Ceneri	%	0,5-1	0,5-1
4/Resistenza alla trazione			
Longitudinale	Kg/mm ²	10-12	10-11
Trasversale	Kg/mm ²	4-5	7-8
5/Allungamento alla rottura			
Longitudinale	%	4-5	8-11
Trasversale	%	8-12	9-12
6/Coefficiente di ritiro massimo			
Longitudinale	%	1	1
Trasversale	%	1,5	1,5
7/Assorbimento olio	%	20...10	15...5
8/Prova di tensione in aria Il materiale resiste 5' alla tensione di prova	KV	0,1 mm.- 1,1 KV 0,2 mm.- 2,2 KV 0,3 mm.- 3 KV 0,4 mm.- 4 KV 0,5 mm.- 5 KV	0,5 mm.- 7,5 KV 1 mm.- 12,5 KV 2 mm.- 23 KV 3 mm.- 31 KV 4 mm.- 37 KV
9/Prova di tensione in olio Il materiale resiste 5' alla tensione di prova	KV	-- -- -- -- --	0,5 mm.- 18 KV 1 mm.- 23 KV 2 mm.- 44 KV 3 mm.- 57 KV 4 mm.- 68 KV 5 mm.- 75 KV

Tutte le determinazioni sono state eseguite secondo le Norme CEI 15-2, ED. XI-1956

(I-PRE) PRESSANN

ISOLANTE ELETTRICO CLASSE Y 90°C

Il PRESSANN è un prodotto in fogli. È un classico cartone isolante duro, pressato, di colore arancio, impiegato nell'industria elettrotecnica particolarmente per la fabbricazione di trasformatori e motori con tensioni di esercizio non molto elevate.

PROPRIETÁ E CARATTERISTICHE	U.M.	PRESSANN IN FOGLI	NORME CEI 15/2 tipo A
1/Peso specifico	g/cm ³	1,10-1,25	1,10-1,25
2/Umidità allo stato di fornitura	%	6-8	8
3/Ceneri	%	4-5	10
4/Resistenza alla trazione			
Longitudinale	Kg/mm ²	5-6	5
Trasversale	Kg/mm ²	3,5-4,5	2,5
5/Allungamento alla rottura			
Longitudinale	%	5-7	--
Trasversale	%	6-9	--
6/Coefficiente di ritiro massimo			
Longitudinale	%	1	1,5
Trasversale	%	1,5	1,5
7/Tensione di perforazione in area istantanea	KV/mm.	0,5 mm. -10-12 1 mm. -10-12 2 mm. -9-11 3 mm. -8-10	-- -- -- --
9/Prova di tensione in olio Il materiale resiste 5' alla tensione di prova	KV	0,5 mm. -13 1 mm. -22 2 mm. -34 3 mm. -45	0,5 mm. 13 1 mm. 20 2 mm. 31 3 mm. 41

N.B. - le determinazioni di cui al par.1/2/3/4/6 sono state eseguite ed. XI-1956. secondo le norme CEI

ISOLANTE ELETTRICO CLASSE B 130°C

Il film POLIESTERE è flessibile e con grande resistenza alla trazione a strappi e a urti. Non contiene plastificanti ed in condizioni normali non degrada nel tempo. È inerte ed impermeabile ad olii e grassi e possiede un alto grado di isolamento elettrico. Viene correttamente impiegato come: isolamento elettrico per motori, generatori, trasformatori, bobine, cavi e conduttori; barriera termica e fisica; agente distaccante, interruttori a membrana. Il film POLIESTERE può essere prodotto in vari spessori, può essere sagomato, termoforato e stampato.

PROPRIETÀ E CARATTERISTICHE	U.M.										
Spessore totale (10%)	μ	0,012	0,023	0,036	0,050	0,075	0,10	0,12	0,19	0,25	35
Resa	m2/Kg.	59,2	30,5	19,9	14,1	9,6	7,2	5,7	3,7	2,9	2,0
Resistenza a trazione											
Longitudinale	Kg./cm.	1750									
Grammatura	g/m2	16,9	33,3	50,0	71,4	105,3	140,8	172,4	263,1	357,1	500,0
Rigidità dielettrica a 25°C	KV	280kV/mm									
Temperatura di esercizio	°C	da 70°C a + 150°C									
Punto di fusione	°C	250°C + 265°C									
Ritiro a 150°C	%	2% + 3%									

DMD ISOTHERM (ROSA SATURO - BIANCO)**ISOLANTE ELETTRICO CLASSE F 155°C - IEC 60216**

L'ISOTHERM è un "tessuto non tessuto" con film poliestere; resistente alle più alte temperature, con elevato potere assorbente ed una eccellente permeabilità all'aria. Consente una saturazione ottimale da vernici o resine, usate nel processo di impregnazione di macchine elettriche. È comunemente usato per tegolini, isolamento intrafase, isolamento di cava, trasformatori. È raccomandato per l'inserzione automatica in motori elettrici, ed è disponibile in più spessori.

PROPRIETÀ E CARATTERISTICHE	U.M.						
Spessore totale (10%)	m./m.	0,15	0,20	0,23	0,30	0,35	0,45
Spessore FILM POL.	μ	50	100	125	190	250	350
Resistenza a trazione							
- Longitudinale	Kg./cm.	14	18	20	25	28	34
- Trasversale	Kg./cm.	14	18	24	27	30	36
Grammatura	g/m ²	165	222	254	329	421	551
Tensione di perforazione	KV	8	10	13	15	18	20
Temperatura di esercizio	°C	da 70°C a + 173°C					
Punto di fusione	°C	260%					
Ritiro a 150°C	%	2%					

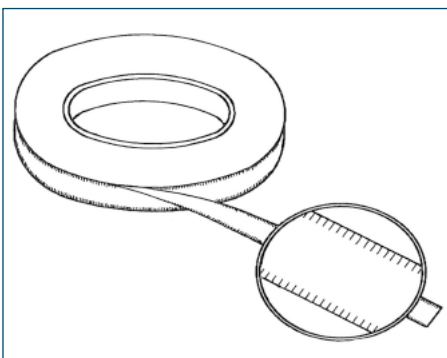
TAGLIO E FRASTAGLIATURA / CUT AND INDENTATION

La CIERRE con la sua tecnologia e le sue attrezzature è in grado di fornire nastri tagliati di ogni materiale flessibile, di qualsiasi spessore ed in tutte le larghezze desiderate a partire da un minimo di 7 mm. La frastagliatura consiste in una serie di cesoiature sui bordi del nastro isolante, che permettono di seguire il raggio di curvatura delle flange, isolando quindi anche il punto più critico della bobina e cioè la congiunzione tra le flange del rocchetto e l'avvolgimento (da 1mm a 7mm).

The CIERRE with its technology and its equipment is able to furnish cut tape of any flexible material, of any thickness and available in any breadth desired starting from 7 mm as a minimum. The indentation consists in a series of snippings on the borders of the insulating tape, it allows to follow the bending radius of the flanges, so that to insulate even the connection between the reel flanges and the winding, that is the most critical point in the bobbin (from 1mm to 7mm).

CELFLEX (FILM POLIESTERE + LATHEROIDE)

ISOLANTE ELETTRICO CLASSE E 120°C

Il CELFLEX è un isolante composto, flessibile, ottenuto mediante accoppiamento di latheroide con un film di poliestere.

Il latheroide, che costituisce il supporto del film, è un materiale dielettrico fabbricato con materie prime purissime, selezionate fra qualità particolarmente pregiate di cellulosa.

Il contenuto di ceneri del CELFLEX non supera mai 1,1%; il contenuto di umidità allo stato di fornitura è inferiore al 70%; il peso specifico è di circa 1,30.

Il CELFLEX è un prodotto ottenuto secondo un metodo che assicura l'intima connessione tra latheroide e film, e riunisce quindi in sé le particolari proprietà dielettriche, meccaniche e termiche dei due componenti, garantendo un superiore isolamento con un minor ingombro di cavo.

Il CELFLEX è caratterizzato da elevata rigidità dielettrica anche in presenza di umidità - minima diminuzione di rigidità dielettrica sulla piegatura, eccezionale resistenza meccanica - stabilità dimensionale, resistenza a lacche isolanti, agenti chimici, oli, grassi alta resistenza termica - appartiene alla classe E dei materiali isolanti, cioè può essere impiegato per la costruzione di macchine che hanno come condizione abituale di funzionamento la temperatura di 120 aC.

Spessori standard 1m 0.13 - 0.18 - 0.23 - 0.28 - 0,33... fino a 0,53.

PROPRIETÀ E CARATTERISTICHE	U.M.	S/25		S/50		S/100	D/25		D/50		D/100	M/25
Spessore totale nominale <i>Epaisserur totale nominale</i>	mm.	0,23	0,43	0,25	0,45	0,20	0,25	0,45	0,15	0,25	0,20	0,45
1.a/ Resistenza a trazione, campioni non piegati <i>Résistance à la traction, sur échantillons plats</i>												
Longitudinale / Long.	N/mm ²	100	90	110	120	90	110	120	75	95	80	110
Trasversale / Trasv.	N/mm ²	45	45	60	70	70	50	50	65	70	70	60
1.a/ Resistenza a trazione, campioni piegati 180° <i>Résistance à la traction, sur échantillons pliés à 180°</i>												
Longitudinale / Long.	N/mm ²	95	85	90	100	80	100	110	70	90	75	100
Trasversale / Trasv.	N/mm ²	35	40	50	50	60	45	45	60	65	65	50
2./ Allungamento a rottura, campioni non piegati <i>Allongement à la ropture, sur échantillons plats</i>												
Longitudinale / Long.	%	7	10	7	8	10	6	7	4	6	6	10
Trasversale / Trasv.	%	15	15	15	15	18	12	15	12	15	12	18
3.a/ Tensione di perforazione, campioni non piegati <i>Tension de perforation, sur échantillons plats</i>	kV	5,5	6,5	7,5	8,5	12	6	7	9	9,5	14	9
3.b/ Tensione di perforazione, campioni piegati 180° <i>Tension de perforation, sur échantillons pliés à 180°</i>	kV	5	6	7	7,5	11	5,5	6	8	9	13	8,5

PROSSIME PRODUZIONI

NUOVI MORSETTI

CR-30A 2 POSTI 3 POSTI
CR-40A 2 POSTI 3 POSTI] CON AGGANCIAMENTO SIA A SCATTO CHE A BAIONETTA

ARTICOLI IN ATTESA DI OMOLOGAZIONE

CR-M30A (RAME / ALLUMINIO) 1 POSTO
CR-M30A 2/3 POSTI
CR-M40A 2/3 POSTI
CR-M63A 1/2/3 POSTI
KT1 - 35A - 50A - 95A
W-M30A1P
PH-M30A1P

CONDIZIONI GENERALI DI VENDITA

- 1- La merce viene venduta f.co ns. stabilimento (salvo patto contrario).
- 2- I pagamenti devono essere effettuati esclusivamente c/o la nostra sede.
- 3- La merce viaggia a rischio del destinatario anche se venduta porto franco.
- 4- La consegna per i prodotti in termoplastico varia da 6 a 8 giorni.
- 5- La consegna per i prodotti in cartogeno o vetroresina varia da 8-15 giorni.
- 6- La produzione degli stampi si aggira intorno ai 50/65 giorni.
- 7- Per qualsiasi controversia è valido il FORO DI MILANO.
- 8- *I resi autorizzati si accettano solo con corriere a noi convenzionato.*
- 9- Eventuali reclami devono essere effettuati entro 15 giorni dal ricevimento merce.
- 10- Le misure riportate sul presente catalogo non sono impegnative e possono essere modificate senza preavviso.

GARANZIA DELLE NOSTRE FORNITURE

Garantiamo le ns. forniture contro tutti i difetti di fabbricazione. La ns. responsabilità è però limitata al solo obbligo di sostituire gratuitamente le forniture difettose senza che si possa richiedere indennità per qualsiasi causa. È dunque compito dell'utilizzatore effettuare controlli prima della fabbricazione in serie.

RIPRODUZIONE VIETATA ANCHE SE PARZIALE DI TESTO, SIMBOLI E DISEGNI. TUTTI I DIRITTI SONO STRETTAMENTE RISERVATI, LA RIPRODUZIONE O LA COMUNICAZIONE A TERZI È VIETATA IN QUALUNQUE FORMA.

GENERAL SALES CONDITIONS

- 1- The merchandise is sold ex-factory (except from different conditions).
- 2- Payments must made exclusively at your office.
- 3- The good travel at the risk of the recipient, even if sold in carriage paid.
- 4- The delivery of products made in thermoplastic varies changes from 6 to 8 days.
- 5- The delivery of products made in <<cartogeno>> or in glass-fiber reinforced plastic changes from 6 to 15 days
- 6- The mould production is about 40/65 days.
- 7- For any trade dispute you should contact the <Foro of Milan>.
- 8- Returns can be accepted only by our forwarder.
- 9 - All complaints can be done within 15 days after the receiving of the good.
- 10- Measures written on this catalogue are not taxative and can be changed without any notice.

GUARANTEE OF OUR SUPPLIES

We guarantee our supplies against all manufacturing defect. Our responsibility is only limited to the free replacement of defeding supplies without The possibility of reuqisting compensation for any reason. It is therefore user's controls before the manufaduring in series.

COPYRIGHT TEXT AND DESIGNS REPRODUCTION NOT ALLOWED NOT EVEN PARTIAL.

4500 METRI QUADRATI AL VOSTRO SERVIZIO

Operiamo nel settore degli isolanti elettrici con 60 anni di esperienza che permette di soddisfare le piu severe esigenze della clientela ed alle migliori condizioni.

Un apposito ufficio tecnico è a disposizione per collaborare, consigliare e risolvere problemi di particolare natura tecnica richiesti dal Cliente.

Un'attrezzatissima officina dotata di macchine modernissime e uno staff di tecnici altamente specializzati permettono la costruzione di stampi di particolare concezione e difficoltà. Operiamo nel settore degli isolanti elettrici con 60 anni di esperienza che permette di soddisfare le piu severe esigenze della clientela

La CieRre est active dans le secteur des supports isolants pour enroulements électriques: les 60 années d'experience nous permettons de satisfaire les exigences les plus sévères de la clientèle, aux meilleures conditions possibles. Un bureau technique adéquat est disponible à collaborer, conseiller et résoudre les problemes de nature technique particulière qui se posent au Client. Un des ateliers les plus fournis équipé de machines les plus modernes ainsi que un staff de techniciens hautement spécialisés permettent la construction des moules réalisés d'une façon compliquée ou de fabrication delicate.

CIERRE operates in the field of insulating supports for electrical windings. With 60 years of experience in this field we can satisfy the most of demanding customers' requirements at the best conditions. An adequate technical office is always on hand for customers satisfaction.

It cooperates, advises and solves any particular problem of technical nature. A very well equipped workshop with modern machine sand highly skilled craftsmen ensures the best construction of any particular or difficult moulds.

Wir sind tätig im Sektor der elektrischen isoliers solierstoffe mit 60 Jahren erfahrung, die uns erlaubt, die strengsten Bedürfnisse unserer Kundschaft sogar unter den besten Bedingungen zu befriedigen. Eine dafür bestimmte abteilung steht zur verfügung für die beratung, mitarbeit und für die lösung besonderer technischen problemen der kunder.

Unsere Werkstatt ist sehr gut ausgestattet und verfügt über die modernste Maschinen, die zusammen mit einem Team von hoch spezialisierten Technikern ermöglicht die Herstellung von Pressformen mit besonderen Entwurfen.

AVVISO IMPORTANTE PER I CLIENTI

NON VI SIETE MAI DOMANDATI DA CHI STATE COMPRANDO?

È PRASSI DIFFUSA MASCHERARE IL NOME DEL PRODUTTORE

ED ALTERARE CERTIFICAZIONI DEL PRODOTTO

PER FAR CREDERE CHE SIA DI UN FABBRICANTE CERTIFICATO.

PERCHÉ?

VIENE FORNITO UN PRODOTTO SCONOSCIUTO

ALL'ACQUIRENTE CHE È ACQUISTATO SUL MERCATO

CON LA SOLA LOGICA DEL MIGLIOR PREZZO

RIVENDUTO CON IL MASSIMO GUADAGNO

E CON IL RISCHIO DI COMPRARE ARTICOLI CONTRAFFATTI

FAI UNA SCELTA CONSAPEVOLE

SCEGLI LA TRASPARENZA

E CHE IL TUO FORNITORE

USI MATERIALI CERTIFICATI

La nostra azienda



STAND FIERA



UFFICIO



UFFICIO



REPARTO STAMPAGGIO



REPARTO COSTRUZIONE STAMPI



STAMPO



MAGAZZINO



MAGAZZINO

**NON BISOGNA ORGANIZZARE I PROPRI PIANI IN BASE
A CIÒ CHE IL NEMICO POTREBBE FARE,
MA ALLA PROPRIA PREPARAZIONE .**

**SOLTANTO QUELLI CHE CALCOLANO MOLTO VINCERANNO;
COLORO CHE CALCOLANO POCO NON VINCERANNO
E TANTO MENO COLORO CHE NON CALCOLANO AFFATTO.**



Cierre[®] s.r.l.

Via Oslavia, 94 - 20823 Desio (MB)

Tel. +39-026420989 / 4 linee r.a.

Fax. +39-026436855 / commerciale

Fax. +39-0266116225 / contabilità

e-mail: cierre@cierreint.it

web: www.cierreint.it

